



CONTOUR

Your satisfaction is our #1 goal. If you have questions or concerns with your vehicle, we suggest you follow these steps:

1. Contact your Sales Representative or Service Advisor at your selling/servicing dealership.
2. If the inquiry or concern remains unresolved, contact the Sales Manager or Service Manager at the dealership.
3. If the inquiry or concern cannot be resolved at the dealership level, please contact the Ford Customer Assistance Center.

In the United States:

**Ford Motor Company
Customer Assistance Center
300 Renaissance Center
P.O. Box 43360
Detroit, MI 48243
1-800-392-3673 (FORD)
TDD for the hearing impaired: 1-800-232-5952**

In Canada:

**Customer Assistance Centre
Ford Motor Company of Canada, Limited
P.O. Box 2000
Oakville, Ontario L6J 5E4
1-800-565-3673 (FORD)**

Outside the U.S. or Canada:

**FORD MOTOR COMPANY
WORLDWIDE EXPORT OPERATIONS
1555 Fairlane Drive
Fairlane Business Park #3
Allen Park, Michigan 48101
Telephone: (313) 317-4282
Fax: (313) 390-0804**

3

All rights reserved. Reproduction by any means, electronic or mechanical, including photocopying, recording, or by any information storage and retrieval system or translation in whole or part is not permitted without written authorization from Ford Motor Company.

Copyright © 1995 Ford Motor Company

Table of Contents

Introductory Information	1
Safety Restraints	7
Starting Your Contour	41
Warning Lights and Gauges	53
Instrument Panel Controls	69
Steering Column Controls	83
Features	93
Electronic Sound Systems	115
Driving Your Contour	139
Roadside Emergencies	163
Customer Assistance	179
Reporting Safety Defects	185
Accessories	189
Servicing Your Contour	195
Quick Index	261
Index.	273
Service Station Information	292

Introductory Information

Ford's Commitment to You

At Ford Motor Company, excellence is the continuous commitment to achieve the best result possible. It is dedication to learning what you want, determination to develop the right concept, and execution of that concept with care, precision, and attention to detail. In short, excellence means being the standard by which others are judged.

Our Guiding Principles

- **Quality comes first.** For your satisfaction, the quality of our products and services must be our number one priority.
- **You are the focus of everything we do.** Our work must be done with you in mind, providing better products and services than our competition.
- **Continuous improvement is essential to our success.** We must strive for excellence in everything we do: in our products — in their safety and value — and in our services, our human relations, our competitiveness, and our profitability.
- **Employee involvement is our way of life.** We are a team. We must treat one another with trust and respect.
- **Dealers and suppliers are our partners.** We must maintain mutually beneficial relationships with dealers, suppliers, and our other business associates.
- **Integrity is never compromised.** Our conduct worldwide must be pursued in a manner that is socially responsible and commands respect for its integrity and for its positive contributions to society.

Things to Know About Using This Guide

Congratulations on the purchase of your new vehicle. This guide has information about the equipment and the options for your new vehicle. You may not have bought all of the options available to you. If you do not know which information applies to your vehicle, talk to your dealer.

This guide describes equipment and gives specifications for equipment that was in effect when this guide was approved for printing. Ford may discontinue models or change specifications or design without any notice and without incurring obligation.

As you read through your owner guide, carefully read all **Warnings** because they tell you how to avoid endangering yourself, your passengers, and other people.

NOTES and WARNINGS

NOTES give you additional information about the subject matter you are referencing.

WARNINGS remind you to be especially careful in those areas where carelessness can cause damage to your vehicle or personal injury to yourself, your passengers or other people. Please read all **WARNINGS** carefully.

 WARNING

Finding Information in This Guide

After you have read this guide once, you will probably return to it when you have a specific question or need additional information. To help you find specific information quickly, you can use the Quick Index or the Index.

Introductory Information

The **Quick Index** at the end of the book provides a page number following each item which indicates where detailed information can be found.

To use the **Index**, turn to the back of the book and search in the alphabetical listing for the word that best describes the information you need. If the word you chose is not listed, think of other related words and look them up. We have designed the Index so that you can find information under a technical term.

Canadian Owners — French Version

French Owner Guides can be obtained from your dealer or by writing to Ford Motor Company of Canada, Limited, Service Publications, P.O. Box 1580, Station B, Mississauga, Ontario L4Y 4G3.

Your Maintenance Schedule and Record Booklet

The *Maintenance Schedule and Record* booklet lists the services that are most important for keeping your vehicle in good condition. A record log is also provided to help you keep track of all services performed.

About the Warranties

Your vehicle is covered by three types of warranties: **Basic Vehicle Warranty**, **Extended Warranties** on certain parts, and **Emissions Warranties**.

Read your *Warranty Information Booklet* carefully to find out about your vehicle's warranties and your basic rights and responsibilities.

If you lose your *Warranty Information Booklet*, you can get a new one free of charge. Contact any Ford or Lincoln-Mercury dealer, or refer to the addresses and phone numbers on the first page of this owner guide.

Buying a Ford Extended Service Plan

If you bought your vehicle in the U.S., you can buy a Ford Extended Service Plan for your vehicle. This optional contract provides service protection for a longer period of time than the basic warranty that comes with your vehicle.

You do not have to buy this option when you buy your vehicle. However, your option to purchase the Ford Extended Service Plan runs out after 18 months or 18,000 miles. See your dealer for more details about the Ford Extended Service Plan.

If you purchased a Canadian vehicle and did not take advantage of the Ford Extended Service Plan at the time of purchase, you may still be eligible. See your dealer for the details.

Breaking Your Vehicle In

Your new vehicle goes through an adjustment or break-in period during the first 1,000 miles (1,600 km) that you drive it. During the break-in period, you need to pay careful attention to how you drive your vehicle.

- **Avoid sudden stops.** Because your vehicle has new brake linings, you should take these steps:
 - Watch traffic carefully so that you can anticipate when to stop.
 - Begin braking well in advance.
 - Apply the brakes gradually.

The break-in period for new brake linings lasts for 100 miles (160 km) of city driving or 1,000 miles (1,600 km) of highway driving.

- **Use only the type of engine oil that Ford recommends.** See *Engine oil recommendations* in the Index. Do not use special “break-in” oils.

Introductory Information

Cleaning the Outside of Your Vehicle

Pollen, bird droppings and tree sap can damage the paint, especially in hot weather. Wash your vehicle as often as necessary to keep it clean.

Take similar precautions if your vehicle is exposed to chemical industrial fallout.

Paint damage resulting from fallout is not related to a defect in paint materials or workmanship and therefore is not covered by warranty. Ford, however, believes that continual improvement in customer satisfaction is a high priority. For this reason, Ford has authorized its dealers to repair, at no charge to the owner, the surfaces of new vehicles damaged by environmental fallout within 12 months or 12,000 miles (20,000 km) of purchase, whichever comes first. Customers may be required to bring their vehicle in for inspection by a Ford representative.

Washing and Polishing Your Vehicle

Wash the outside of your vehicle, including the underside, with a mild detergent.

DO NOT:

- Wash your vehicle with hot water
- Wash your vehicle while it sits in direct sunlight
- Wash your vehicle while the body is hot

Polish your vehicle to remove harmful deposits and protect the finish.

Cleaning Chrome and Aluminum Parts

Wash chrome and aluminum parts with a mild detergent. Do not use steel wool, abrasive cleaners, fuel or strong detergents.

Cleaning Plastic Parts

Some of your vehicle's exterior trim parts are plastic. Clean with a tar and road oil remover if necessary. Use a vinyl cleaner for routine cleaning.

Do not clean plastic parts with thinners, solvents or petroleum-based cleaners.

If you have your vehicle rustproofed, remove oversprayed rustproofing with a tar and road oil remover. If rustproofing is not removed from plastic and rubber parts, it can cause deterioration.

Safety Restraints

Important Safety Belt Information

The use of safety belts helps to restrain you and your passengers in case of a collision. In most states and in Canada the law requires their use.

Safety belts provide best restraint when:

- the seatback is upright
- the occupant is sitting upright (not slouched)
- the lap belt is snug and low on the hips
- the shoulder belt is snug against the chest
- the knees are straight forward

To help you remember to fasten your safety belt, a warning light may come on and a chime may sound. See *Safety Belt Warning Light and Chime* in the *Warning Lights and Gauges* chapter.

See the following sections in this chapter for directions on how to properly use these safety belts. Also see *Safety Restraints for Children* in this chapter for special instructions about using safety belts for children.

 WARNING
Make sure that you and your passengers wear safety belts. Always drive and ride with your seatback upright and the lap belt snug and low across the hips.

⚠ WARNING

Never wear the shoulder belt under the arm. Never swing it around the neck over the inside shoulder. Never use a single belt for more than one person or across more than one seating position. Each seating position in your vehicle has a specific safety belt assembly which is made up of one buckle and one tongue that are designed to be used as a pair. Failure to follow these precautions could increase the risk and/or severity of injury in a collision.

⚠ WARNING

Ford recommends that all safety belt assemblies and attaching hardware should be inspected by a qualified technician after any collision. Safety belt assemblies not in use during a collision should also be inspected and replaced if either damage or improper operation is noted.

⚠ WARNING

To reduce the risk of serious injury in a collision, children should always ride with the seatback upright.

Safety Restraints

 WARNING
--

<p>Never let a passenger hold a child on his or her lap while the vehicle is moving. The passenger cannot protect the child from injury in a collision.</p>
--

Lock the doors of your vehicle before driving to lessen the risk of the door coming open in a collision.

Combination Lap and Shoulder Belts

While your vehicle is in motion, the combination lap and shoulder belt adjusts to your movement. However, if you brake hard, turn hard, or if your vehicle receives an impact of 5 mph (8 km/h) or more, the lap and shoulder belt locks and helps reduce your forward movement.

After you get into your vehicle, close the door and lock it. Then adjust the seat to the position that suits you best.

Pull the combination lap/shoulder belt from the retractor so that the shoulder portion of the belt crosses your shoulder and chest. Be sure the belt is not twisted. If it is, remove the twist. Insert the belt tongue into the proper buckle until you hear a snap and feel it latch. Make sure the tongue is securely fastened to the buckle by pulling on tongue.

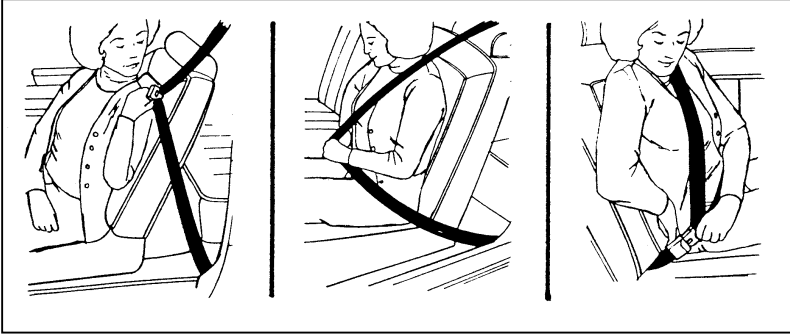

Fastening the front seat lap and shoulder belt

NOTE: Be sure to read and understand *Important Safety Belt Information* at the beginning of this chapter.

To adjust the lap part of the belt, pull up on the shoulder belt until the lap belt fits snugly and as low as possible around your hips.

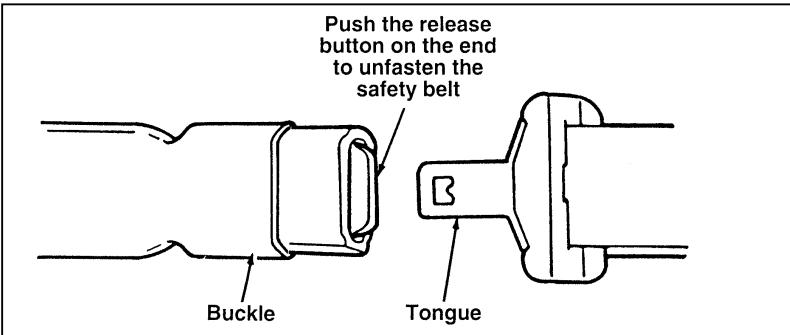

Unfastening the combination lap and shoulder belts

While the belt retracts, guide the tongue to its original position to prevent it from striking you or the vehicle.

Safety Restraints

Dual Locking Mode Lap/Shoulder Belt Retractor

The front passenger seat and the rear outer seat combination lap and shoulder belts are equipped with a dual locking mode retractor on the **shoulder** belt portion of the lap/shoulder belt. This retractor can be switched from vehicle sensitive (emergency) locking mode to automatic locking mode by pulling the belt webbing all of the way out of the retractor. The retractor modes function as follows.

Vehicle sensitive (emergency) locking mode

In this operating mode, the lap/shoulder belt retractor will allow the occupant freedom of movement, locking tight only on hard braking, hard cornering or impacts of approximately 5 mph (8 km/h) or more.

Automatic locking mode

This mode must be used when installing a child seat on the front passenger seat and rear seats where dual locking retractors are provided. To switch the retractor from the emergency locking mode to the automatic locking mode, perform the following steps:

 WARNING
--

Rear facing infant seats should never be placed in the front seat.

1. Buckle the lap/shoulder combination belt.
2. Grasp the shoulder portion of the belt and pull downward until all of the belt is extracted and a click is heard. At this time, the retractor is in the automatic locking mode (child restraint mode).
3. Allow the belt to retract. A clicking sound will be heard as the belt retracts. This indicates that the retractor is in the automatic locking mode.

-
4. Pull up on the shoulder belt to remove slack in the lap belt.

NOTE: When the combination lap/shoulder belt is unbuckled and allowed to retract completely, the retractor will switch to the vehicle sensitive (emergency) locking mode. See the detailed instructions under *Safety Seats for Children* in this chapter.

Shoulder Belt Height Adjustment

Driver and right front passenger

You can adjust the shoulder belt height to one of four (4) positions.

To adjust the belt down, push the release button (see figures 1 and 2). To adjust the belt up, slide the adjuster up. (You do not have to push the release button.)

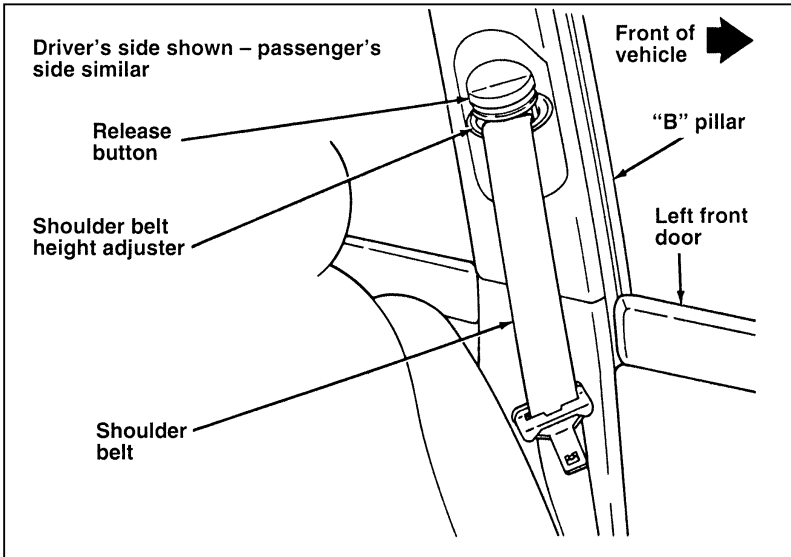

Figure 1 — The shoulder belt height adjuster

Safety Restraints

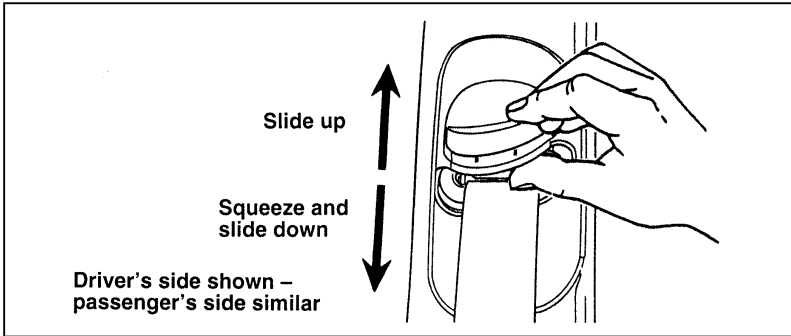

Figure 2 — Adjusting the shoulder belt height

Make sure the adjuster is firmly in one of the four positions. The belt should be adjusted up or down until the belt rests on your shoulder near your neck.

WARNING

Position the shoulder belt height adjuster so that the belt rests across the middle of your shoulder. Be sure the shoulder belt is properly positioned on your shoulder each time you use the belt. If the shoulder belt is off your shoulder, on your upper arm or neck, there is a greater risk of severe injury in a collision.

Lap Belts

The lap belt in the center of the rear seat does not adjust automatically. You must adjust it to fit snugly and as low as possible around your hips. Do not wear it around your waist.

Pull the belt across your hips and **insert the tongue into the correct buckle** on your seat until you hear a snap and feel it lock. Make sure the buckle is securely fastened.

If you need to lengthen the belt, unfasten it and tip the belt tongue at a right angle to the belt. Pull the belt tongue over your lap until it reaches the buckle.

If you need to shorten the belt, pull on the loose end of the webbing until the belt fits snugly.

To unfasten the belt, push the release button on the end of the buckle. This allows the tongue to unlatch from the buckle.

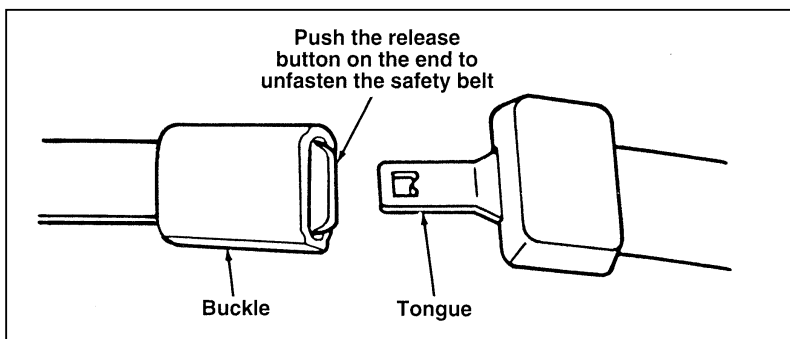

Unfastening the lap belt in center rear seating position

Safety Belt Extension Assembly

For some people, the safety belt may be too short even when it is fully extended. You can add about eight inches (20 cm) to the belt length with a safety belt extension assembly (part number 611C22). Safety belt extensions are available at no cost from your dealer.

Use only extensions manufactured by the same supplier as the safety belt. Manufacturer identification is located at the end of the webbing on the label. Also, use the safety belt extension only if the safety belt is too short for you when fully extended. Do not use extension to change the fit of the shoulder belt across the torso.

Safety Restraints

 WARNING
--

Failure to follow these instructions will affect the performance of the safety belts and increase the risk of personal injury.

Safety Belt Maintenance

Check the safety belt systems periodically to make sure that they work properly and are not damaged.

All safety belt assemblies, including retractors, buckles, front seat belt buckle support assemblies (slide bar) (if equipped), child safety seat tether bracket assemblies (if equipped), and attaching hardware, should be inspected after any collision. Ford recommends that all safety belt assemblies used in vehicles involved in a collision be replaced. However, if the collision was minor and a qualified technician finds that the belts do not show damage and continue to operate properly, they do not need to be replaced. Safety belt assemblies not in use during a collision should also be inspected and replaced if either damage or improper operation is noted.

Safety Belt Warning Label

A warning label has been placed on the buckle of each of your vehicle's front seat safety belts.

In a collision of sufficient severity while the safety belt is in use, the safety belt buckle will pull out of the sleeve so that all or part of the orange portion of the label is visible.

 WARNING
--

Whenever the orange portion of the label is visible, the safety belt must be replaced.

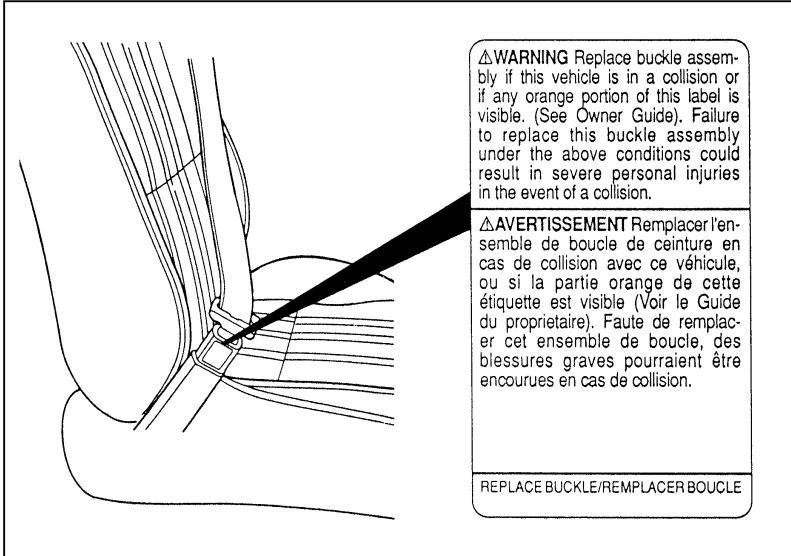

The warning label on the front seat safety belt buckle

Cleaning the Safety Belts

Clean the safety belts with any mild soap solution that is recommended for cleaning upholstery or carpets. Do not bleach or dye the belt webbing because this may weaken it.

Air Bag Supplemental Restraint System (SRS)

The driver and right front passenger air bags are Supplemental Restraint Systems (SRS), provided at these seating positions in addition to the lap/shoulder belt, and are designed to supplement the protection provided to properly belted occupants in moderate to severe frontal collisions. The supplemental air bag system does not provide restraint to the lower body.

Safety Restraints

The Importance of Wearing Safety Belts

⚠ WARNING

All occupants of the vehicle, including the driver, should always wear their safety belts, even when an air bag Supplemental Restraint System is provided.

There are four very important reasons to use safety belts even with an air bag system. Use your safety belts to:

- help keep you in the proper position (away from the air bag) when it inflates
- reduce the risk of harm in rollover, side or rear impact collisions, because an air bag is not designed to inflate in such situations
- reduce the risk of harm in frontal collisions that are not severe enough to activate the supplemental air bag
- reduce the risk of being thrown from your vehicle

The Importance of Being Properly Seated

⚠ WARNING

If a passenger is not properly seated and restrained, an inflating air bag could cause serious injury.

In a collision, the air bag must inflate extremely fast to help provide additional protection for you. In order to do this, the air bag must inflate with considerable force. If you are not seated in a normal riding position with your back against the seatback, the air bag may not protect you properly and could possibly hurt you as it inflates.

⚠ WARNING

Rear-facing infant seats should never be placed in the front seat.

In rear-facing infant seats, the infant's head is closer to the air bag. The force of the rapidly inflating air bag could push the top of the rear-facing seat against the vehicle seatback or center armrests (if so equipped), or center console (if so equipped). **REAR-FACING INFANT CARRIERS MUST ALWAYS BE SECURED IN THE REAR SEAT**, and other child safety seats and infant seats should be secured in the rear seat whenever possible.

⚠ WARNING

When using forward-facing child seats move the passenger seat as far back from the instrument panel as possible. NEVER SECURE REAR-FACING INFANT SEATS IN THE FRONT SEAT.

Your vehicle is equipped with a right front passenger air bag. Air bags deploy with great force, faster than the blink of an eye. Front passengers, especially children and small adults, must never sit on the front edge of the seat, stand near the glove compartment of the instrument panel, or lean over near the air bag cover when the vehicle is moving. All occupants should sit with their backs against the seatback, move the seat to the most rearward position if possible and use the safety belts. Children weighing less than 40 lbs. (18 kg) always should use child or infant seats.

Safety Restraints

 WARNING
--

<p>Do not place objects or mount equipment on or near the air bag cover on the steering wheel or in front seat areas that may come in contact with a deploying air bag. Failure to follow this instruction may increase the risk of personal injury in the event of a collision.</p>

For further information about the proper mounting of equipment in the front seat of this vehicle, please refer to Ford's brochure entitled *Some Important Information About Air Bag Supplemental Restraint System* which can be obtained by calling Helm Inc. at 1-800-782-4356. Ask for brochure FPS-8602.

For additional important safety information on the proper use of seat belts, child seats, and infant seats, please read the other sections of this part of the Owner Guide, especially sections entitled *Safety Belts for Children* and *Safety Seats for Children*.

How the Air Bag Supplemental Restraint System Operates

The driver air bag is in the center of the steering wheel. The front passenger seat air bag is located in the center of the instrument panel ledge above the glove compartment. Both air bags are designed to stay out of sight until they are activated.

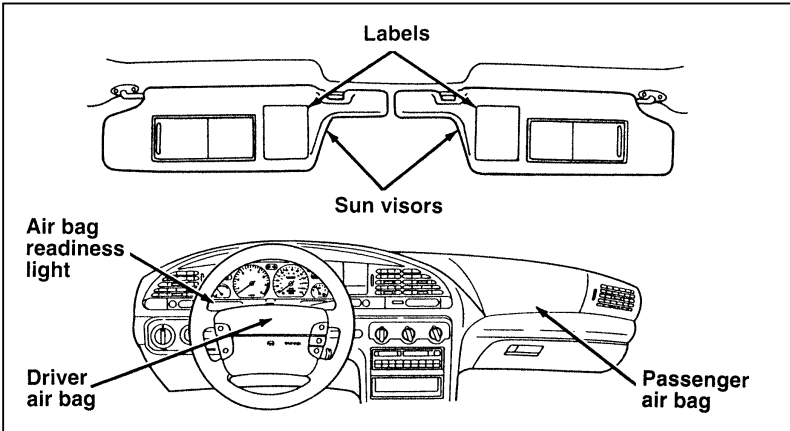

The location of air bags and warning labels

Safety Restraints

If a collision occurs, the sensors sense the severity of the impact and activate the air bags if necessary. The air bag system is designed to deploy in frontal and front-angled collisions more severe than hitting a parked vehicle (of similar size and weight) head-on at about 28 mph (45 km/h). Because the system senses the crash severity rather than vehicle speed, some frontal collisions at speeds above 28 mph (45 km/h) will not inflate the air bag.

When the sensors activate the system, the air bags inflate rapidly, filling with non-toxic nitrogen gas in a fraction of a second. Immediately after inflation, the air bags deflate by releasing the nitrogen gas through vent holes. The whole process takes place in a matter of seconds.

 WARNING
Air bag system components get hot after inflation. Do not touch them after inflation.



Inflated driver-side air bag

Safety Restraints

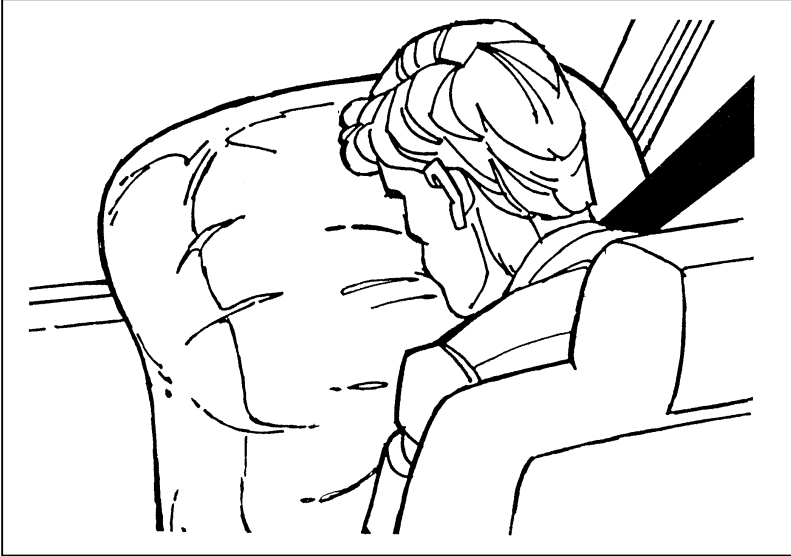

Inflated passenger-side air bag

WARNING

If the air bag is inflated, THE AIR BAG WILL NOT FUNCTION AGAIN AND MUST BE REPLACED IMMEDIATELY. If the air bag is not replaced, the unrepaired area will increase the risk of injury in a collision.

To ensure that the air bag system will operate as intended in a crash, the system is equipped with a diagnostic module, which controls a readiness lamp and a warning tone. The diagnostic module monitors its own circuits, the air bag electrical system, the air bag readiness light, the air bag power, and the air bag inflators.

The air bag system uses a readiness light on the instrument cluster and a tone to indicate the condition of the system. When you turn the ignition key to the ON position, this light will illuminate for approximately six (6) seconds and then turn off. This indicates that the system is operating normally. NOTE: Maintenance of the air bag system is not required.

A problem with the system is indicated by one or more of the following:

- the readiness light will either flash or stay lit,
- or it will not light immediately after ignition is turned on,
- or a group of five beeps will be heard. The tone pattern will repeat periodically until the problem and light are repaired.

If any of these things happen, have the air bag system serviced at your Ford or Lincoln-Mercury dealer immediately. Unless serviced, the air bag supplemental restraint system may not function properly in the event of a collision.

 WARNING
--

<p>Do not attempt to service, repair, or modify the Air Bag Supplemental Restraint System or its fuses. See your Ford or Lincoln-Mercury dealer.</p>

Disposal of air bags or air bag equipped vehicles

For disposal of air bags or air bag equipped vehicles, see your local Ford or Lincoln-Mercury dealer. Air bags **MUST** be disposed of by qualified personnel.

Safety Restraints

Safety Restraints for Children

In the U.S. and Canada, you are required by law to use safety restraints for children. If small children ride in your vehicle — this generally includes children who are four years old or younger and who weigh 40 pounds (18 kg) or less — you must put them in safety seats that are made specially for children. Safety belts alone do not provide maximum protection for these children. Check your local and state laws for specific requirements.

⚠ WARNING

Never let a passenger hold a child on his or her lap while the vehicle is moving. The passenger cannot protect the child from injury in a collision.

⚠ WARNING

Passengers should not be allowed to ride in the cargo area. Persons not riding in a seat with a fastened seat belt are much more likely to suffer serious injury in a collision. Cargo should always be secured to prevent it from shifting and causing damage to the vehicle or harm to passengers.

When possible, put children in the rear seat of your vehicle. Accident statistics suggest that children are safer when properly restrained in the rear seating positions than in the front seating positions.

⚠ WARNING

Carefully follow all of the manufacturer's instructions included with the safety seat you put in your vehicle. If you do not install and use the safety seat properly, the child may be injured in a sudden stop or collision.

⚠ WARNING

Safety belts and seats can become hot in a vehicle that has been closed up in sunny weather; they could burn a small child. Check seat covers and buckles before you place a child anywhere near them.

⚠ WARNING

Never leave a child unattended in your vehicle.

Safety Seats for Children

Use a safety seat that is recommended for the size and weight of the child. Always follow the safety seat manufacturer's instructions when installing and using the safety seat.

Ford recommends the use of a child safety seat having a top tether strap. Install the child safety seat in a seating position which is capable of providing a tether anchorage. For more information on top tether straps see *Attaching Safety Seats With Tether Straps* in this chapter.

Your vehicle is equipped with a right front passenger air bag. Air bags deploy with great force, faster than the blink of an eye. Front passengers, especially children and small adults, must never sit on the front edge of the seat, stand near the glove compartment of the instrument panel, or lean over near the air bag cover when the vehicle is moving. All occupants should sit with their backs against the seatback, move the seat to the most rearward position if possible and use the safety belts. Children weighing less than 40 lbs. (18 kg) always should use child or infant seats.

Safety Restraints

⚠ WARNING

When using forward-facing child seats move the passenger seat as far back from the instrument panel as possible. NEVER SECURE REAR-FACING INFANT SEATS IN THE FRONT SEAT.

THE FORCE OF THE RAPIDLY INFLATING PASSENGER AIR BAG COULD PUSH THE TOP OF THE REAR-FACING SEAT AGAINST THE VEHICLE SEATBACK, ARMRESTS OR CONSOLE. REAR-FACING INFANT SEATS MUST ALWAYS BE SECURED IN THE REAR SEAT. Failure to follow these instructions could result in serious injury.

All child restraint systems are designed to be secured in vehicle seats by lap belts or by the lap portion of a lap-shoulder belt.

⚠ WARNING

If you do not properly secure the safety seat, the child occupying the seat may be injured during a collision or sudden stop. An unsecured safety seat could also injure other passengers.

⚠ WARNING

Carefully follow all of the manufacturer's instructions included with the safety seat you put in your vehicle. If you do not install and use the safety seat properly, the child may be injured in a sudden stop or collision.

When installing a child safety seat, be sure to use the correct safety belt buckle for that seating position, and make sure the tongue is securely fastened in the buckle.

⚠ WARNING

Always keep the buckle release button pointing upward and away from the child seat, with the tongue between the child seat and the release button as shown in the following illustration.

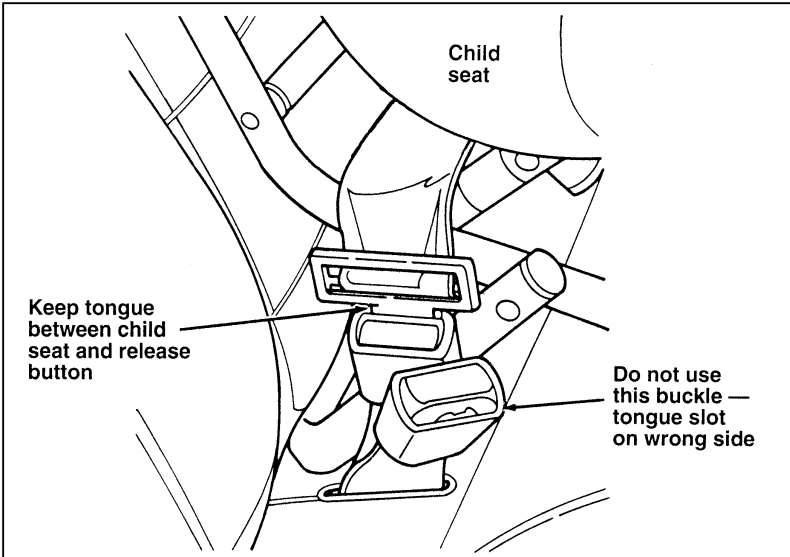

Safety belt buckle placement for child seats

Safety Restraints

Installing Child Safety Seats in the Front Passenger Seat and Outer Rear Seating Positions

Your vehicle is equipped with a dual locking mode retractor on the shoulder belt portion of the combination lap/shoulder safety belt for the right front seat passenger and rear outer passengers.

If you choose to install a child safety seat in the front seating position, move vehicle seat as far back as possible.

1. Position the child seat in center of passenger seat.
2. Pull down on shoulder belt, then grasp shoulder belt and lap belt together. Figure 1.

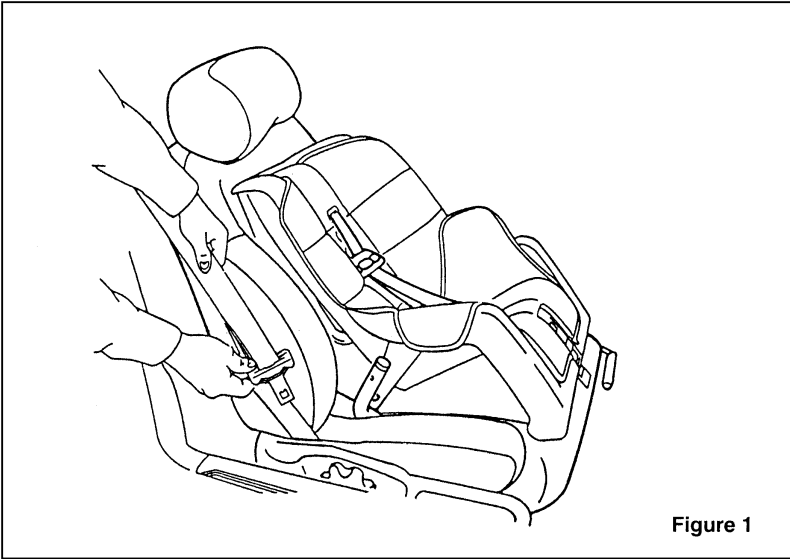

-
3. While holding the shoulder and lap belt portions together, route the tongue through the child seat according to the child seat manufacturer's instructions. See Figure 2. Be sure that the belt webbing is not twisted.

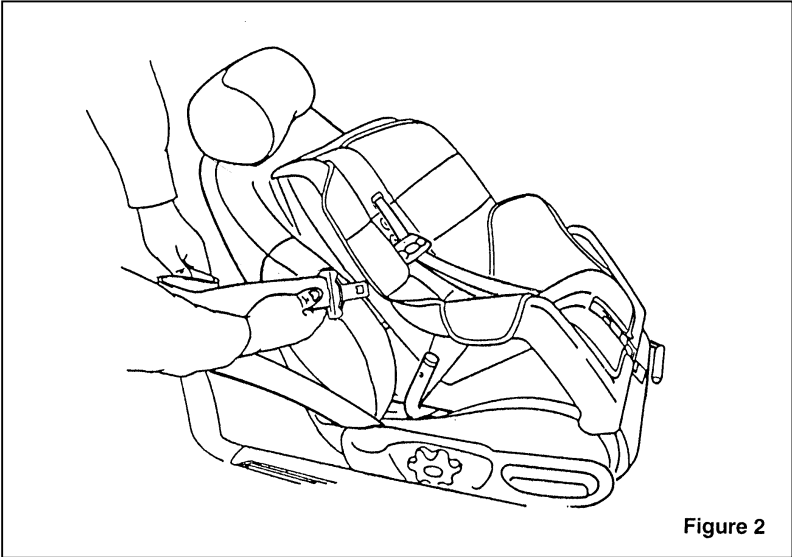

Figure 2

Safety Restraints

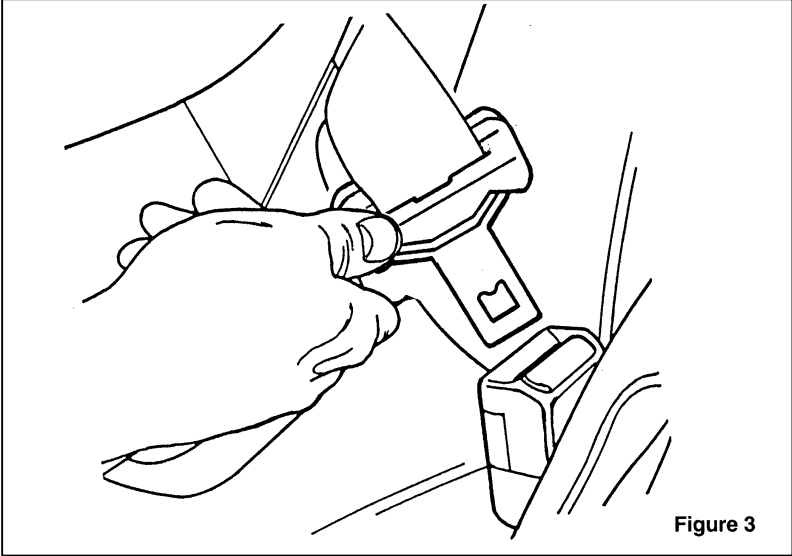
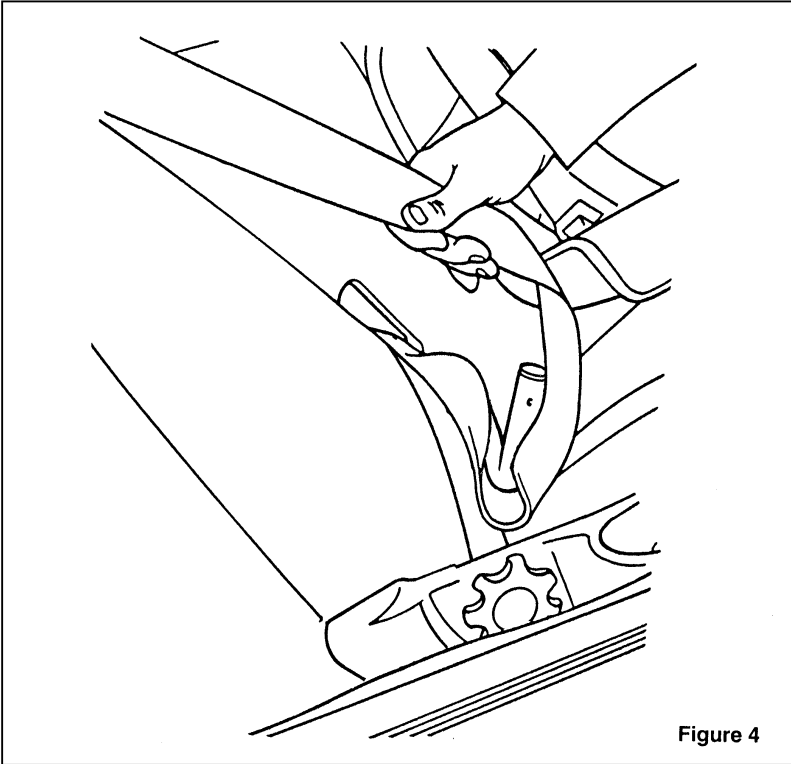

Figure 3

-
4. Grasp the shoulder portion of the belt and pull downward until all of the belt is extracted from the reel and a click is heard. At this time the retractor is in the automatic locking mode (child restraint mode). Figure 4.



Safety Restraints

5. Allow the belt to retract. Pull up on the shoulder webbing. A clicking sound will be heard as the belt retracts. This indicates the retractor is in the automatic locking mode. Push down on the child seat while you pull up on the belt to remove any slack in the belt. Figures 5 and 6.

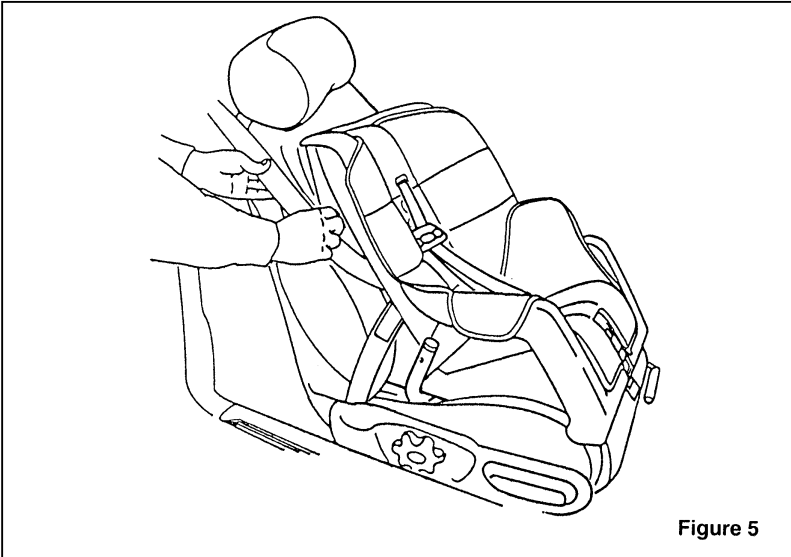

**Push down on child
safety seat while
pulling up on the
shoulder belt webbing**

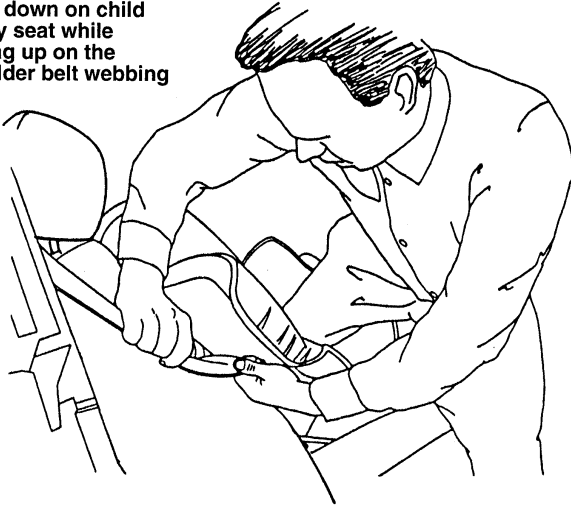
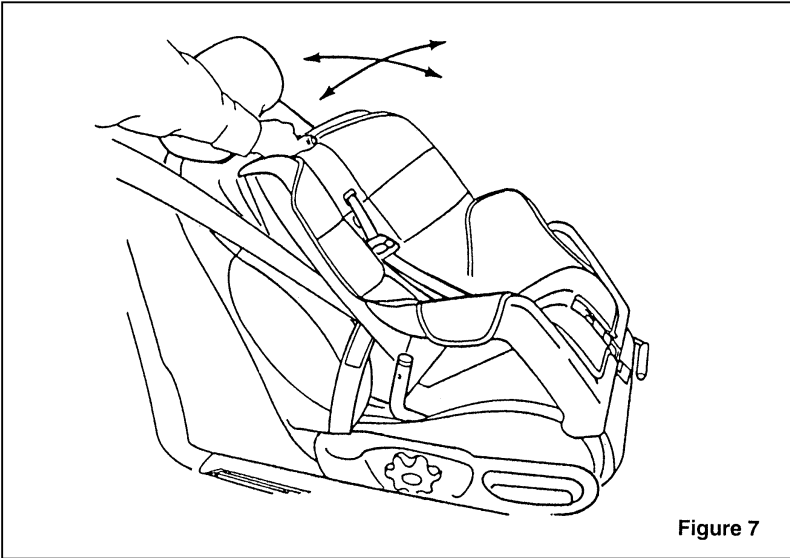

Figure 6

Safety Restraints

6. Before placing the child in the child seat, forcibly tilt the seat from side to side, and tug it forward to make sure that the seat is securely held in place, Figure 7.



-
7. Double check that the retractor is in the automatic locking mode. Try to pull more belt out of the retractor. If you cannot, the belt is in the automatic locking mode, Figure 8.

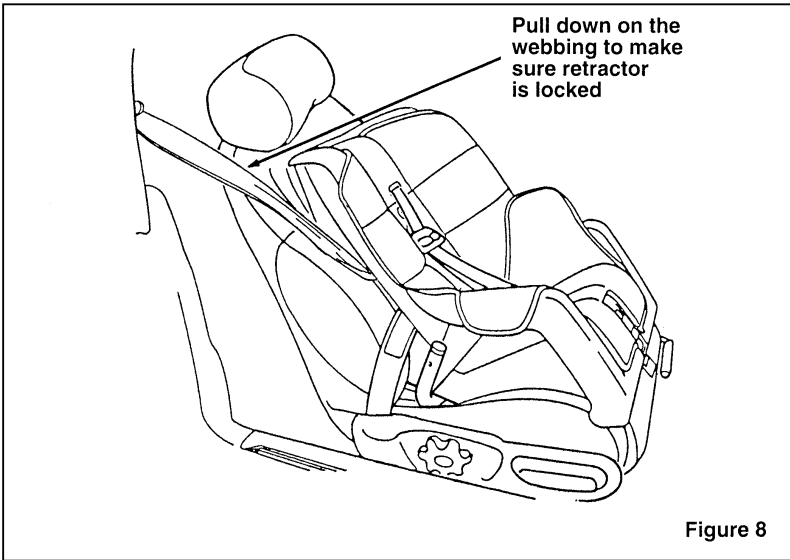

8. Check to make sure that the child seat is properly secured prior to each use. If the belt is not locked, repeat steps 4 through 7.

To remove retractor from automatic lock mode, unbuckle the belt and allow the webbing to retract fully. A click will be heard as the belt retracts. The belt is back in normal operating mode (vehicle sensitive emergency locking mode) when this click disappears.

Safety Restraints

 WARNING
--

<p>Carefully follow all of the manufacturer's instructions included with the safety seat you put in your vehicle. If you do not install and use the safety seat properly, the child may be injured in a sudden stop or collision.</p>
--

Installing Child Safety Seats in the Rear Center Seating Position

Some child safety seats are too wide to fit in the rear center seat. Choose a child safety seat with a narrow base that can fit between the safety belt buckles.

Attaching Safety Seats With Tether Straps

Some manufacturers make safety seats that include a tether strap that goes over the back of the vehicle seat and attaches to an anchoring point. Other manufacturers offer the tether strap as an accessory. Contact the manufacturer of your child safety seat for information about ordering a tether strap.

To install a tether from a child safety seat in the front seat, route the tether strap under the vehicle seat head restraint and hook the tether hook into the hole in the tongue of the center rear lap belt. After the hook is in the hole, pull on the loose end of the lap belt webbing to shorten the belt and tighten the tether strap.

To install a tethered child safety seat in the rear seat, you will need tether anchorage hardware.

Tether anchorage hardware (Canadian vehicles only)

All vehicles built for sale in Canada include a tether anchor hardware kit for use with child safety seats. Attachment holes (at each rear seating position) have been provided in your vehicle to attach the anchor hardware, if required. Additional kits can be obtained at no charge from any Ford or Lincoln-Mercury dealer.

Tether anchorage hardware (USA vehicles only)

All vehicles built for sale in the USA do not include a tether anchor hardware kit for use with child safety seats. However, attachment holes (at each rear seating position) have been provided in your vehicle to attach the tether anchor hardware. If tether anchorage hardware is required for the child safety seat, use only the tether anchor kit available at no charge from any Ford or Lincoln-Mercury dealer (Base part number 613D74).

Safety Belts for Children

Children who are too large for child safety seats should always wear safety belts. (See instructions with your child seat, or contact its manufacturer, to determine maximum size of child that will safely fit in the seat.)

 WARNING
--

If safety belts are not properly worn and adjusted as described, the risk of serious injury to the child in a collision will be much greater.
--

If the shoulder belt portion of one of the lap and shoulder belts can be positioned so that it does not cross or rest in front of the child's face or neck, the child should wear the lap and shoulder belt. Moving the child closer to the center of the vehicle may help provide a good shoulder belt fit.

Safety Restraints

To improve the fit of lap and shoulder belts on children who have outgrown child safety seats, Ford recommends use of a belt-positioning booster seat that is labelled as conforming to all Federal motor vehicle safety standards. Belt-positioning booster seats raise the child and provide a shorter, firmer seating cushion that encourages safer seating posture and better fit of lap and shoulder belts on the child. A belt-positioning booster should be used if the shoulder belt rests in front of the child's face or neck, or if the lap belt does not fit snugly on both thighs, or if the thighs are too short to let the child sit all the way back on the seat cushion when the lower legs hang over the edge of the seat cushion. You may wish to discuss the specific needs of your child with your pediatrician.

 WARNING
--

Do not use a belt-positioning booster with a lap-only belt.
--

Lap belts and the lap belt portion of lap and shoulder belts should always be worn snugly and below the hips, touching the child's thighs.

 WARNING
--

To reduce the risk of serious injury in a collision, children should always ride with the seatback upright.
--

Starting Your Contour

Ignition

Understanding the Positions of the Ignition

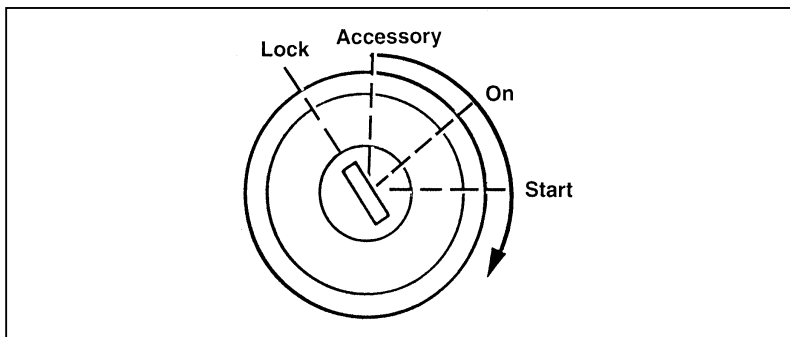

The positions of the key in the ignition

LOCK and ACCESSORY lock the gearshift for all vehicles with an automatic transaxle.

⚠ WARNING

LOCK position does not lock the gearshift on floor-mounted manual transaxle gearshifts. If the parking brake is not set and the gearshift is moved out of gear, your vehicle may move unexpectedly and injure someone.

The automatic transaxle gearshift must be in P (Park) to move the key to the LOCK position.

LOCK is the only position that allows you to remove the key. The LOCK feature helps to protect your vehicle from theft.

If your key is stuck in the LOCK position and will not turn, move your steering wheel left or right until the key turns freely.

ACCESSORY allows some of your vehicle's electrical accessories to operate while the engine is not running. For example, you can use ACCESSORY to turn on the radio without starting the engine.

ON allows you to test your vehicle's warning lights (except the brake system warning light) to make sure they work before you start the engine. The key returns to the ON position once the engine is started and remains in this position while the engine runs.

START cranks the engine. Release the key once the engine starts so that you do not damage the starter. The key should return to ON when you release it. The START position also allows you to test the brake warning light.

Removing the Key From the Ignition

Procedures for removing your key from the ignition vary, depending on whether your vehicle has an automatic or manual transaxle.

If your vehicle has an automatic transaxle:

1. Put the gearshift lever in P (Park).
2. Set the parking brake fully.
3. Rotate the ignition key to the LOCK position.
4. Remove the key from the ignition.

If your vehicle has a manual transaxle:

1. Put the gearshift lever in 1 (First).
2. Set the parking brake fully.
3. Rotate the ignition key to the LOCK position.
4. Remove the key from the ignition.

Starting Your Contour

The steering wheel locks when the key is removed.

If the driver's door is open while the key is still in the ignition, a warning chime sounds.

⚠ WARNING

Always set the parking brake fully and make sure that the gearshift is securely latched in P (Park) (automatic transaxle) or in 1 (First) (manual transaxle).
--

⚠ WARNING

Do not leave children, unreliable adults, or pets alone in your vehicle. They could accidentally injure themselves or others through inadvertent operation of the vehicle. Further, on hot, sunny days, temperatures in a closed vehicle could quickly become high enough to cause severe and possibly fatal injuries to people as well as animals.
--

Fuel-Injected Engines

When starting a fuel-injected engine, **the most important thing to remember is to avoid pressing down on the accelerator before or during starting.** Only use the accelerator when you have problems getting your vehicle started. See *Starting Your Engine* in this chapter for details about when to use the accelerator while you start your vehicle.

Starting Your Vehicle

Preparing to Start Your Vehicle

 WARNING
--

<p>Do not start your vehicle in a closed garage or other enclosed area. Never sit in a stopped vehicle for more than a short period of time with the engine running. Exhaust fumes are toxic. See <i>Guarding Against Exhaust Fumes</i> in this chapter for more instructions.</p>

Before you start your vehicle, do the following:

1. Make sure you and all your passengers buckle your safety belts. See *Safety Restraints* in the Index for more details.
2. Make sure your headlamps and other accessories are turned off and the parking brake is set.
3. **If you have a manual transaxle**, make sure that the parking brake is fully set, push the clutch pedal to the floor, and put the gearshift into Neutral before you turn the key.
(Remember, the starter will operate only if the clutch pedal is pushed all the way to the floor.)

If you have an automatic transaxle, make sure that the gearshift is in P (Park) and the parking brake is set before you turn the key.

Starting Your Contour

Before you start your vehicle, you should test the warning lights on the instrument panel to make sure that they work. Refer to the *Warning Lights and Gauges* chapter.

Starting Your Engine

To start your engine:

1. Follow the steps under *Preparing to Start Your Vehicle* at the beginning of this section.
2. Keep your foot on the brake pedal and turn the ignition key to the ON position.
3. DO NOT depress the accelerator pedal when starting your engine. DO NOT use the accelerator while the vehicle is parked.
4. Turn the key to the START position (cranking) until the engine starts. Allow the key to return to the ON position after the engine has started.

If you have difficulty in turning the key, rotate the steering wheel slightly because it may be binding.

For a cold engine:

2.0L engine:

- At temperatures **below -10°F (-23°C)**: Turn the key to ON, crank the engine and depress the accelerator about 1/4 of the way down and hold that position for **five (5) seconds**. If the engine fails to start, continue to crank with the accelerator depressed about 1/4 of the way down and hold that position until the engine starts. **DO NOT crank for more than 30 seconds**, or you could damage the starter. If the engine fails to start on the first try, turn the key to OFF and wait two (2) minutes before trying again. Allow engine to warm up for a few minutes before putting transaxle into gear.
- At temperatures **between -10°F (-23°C) and 10°F (-12°C)**: Turn the key to ON, and crank the engine for **five (5) seconds**. If the engine fails to start, continue to crank and depress the accelerator about 1/4 of the way down and hold that position until the engine starts. **DO NOT crank for more than 30 seconds**, or you could damage the starter. If the engine fails to start on the first try, turn the key to OFF and wait two (2) minutes before trying again.
- At temperatures **between 10°F (-12°C) and 32°F (0°C)**: If the engine does not start in **fifteen (15) seconds** on first try, turn the key to OFF, then try again.
- At temperatures **above 32°F (0°C)**: If the engine does not start in **five (5) seconds** on the first try, turn the key to OFF, then try again.

If you have the 4-cylinder 2.0L engine and are not using an engine block heater, warm up the engine for a minute or two before putting the transaxle in gear. Depressing the accelerator slightly will also help with cold starts.

Starting Your Contour

2.5L engine:

- At temperatures **10°F (-12°C) and below**: If the engine does not start in **fifteen (15) seconds** on the first try, turn the key to OFF, wait approximately ten (10) seconds so you do not flood the engine, then try again.
- At temperatures **above 10°F (-12°C)**: If the engine does not start in **five (5) seconds** on the first try, wait approximately ten (10) seconds so you do not flood the engine, then try again.

For a warm engine:

- Do not hold the key in the START position for more than **five (5) seconds** at a time. If the engine does not start within five (5) seconds on the first try, wait a few seconds after the starter stops, then try again.

Whenever you start your vehicle, release the key as soon as the engine starts. Excessive cranking could damage the starter or flood the engine.

After you start the engine, let it idle for a few seconds. Keep your foot on the brake pedal and put the gearshift lever in gear. Release the parking brake. Slowly release the brake pedal and drive away in the normal manner.

NOTE: If your vehicle is equipped with an automatic transaxle, your vehicle has an interlock that prevents you from shifting out of P (Park) unless your foot is on the brake pedal.

If the engine does not start after two attempts:

1. Press the accelerator pedal all the way to the floor and hold it.
2. Turn the ignition key to the START position.
3. Release the ignition key when the engine starts.

-
4. Release the accelerator gradually as the engine speeds up. Then drive away in the normal manner.

If the engine still does not start, the fuel pump shut-off switch may have been triggered. For directions on how to reset the switch see *Fuel Pump Shut-Off Switch* later in this chapter.

A computer system controls the engine's idle speed. When you start your vehicle, the engine's idle speed normally runs high. These faster engine speeds will make your vehicle move slightly faster than its normal idle speed. It should, however, slow down after a short time. If it does not, have the idle speed checked.

If the engine idle speed does not slow down automatically, do not allow your vehicle to idle for more than 10 minutes. Have the vehicle checked.

 WARNING
--

Extended idling at high engine speeds can produce very high temperatures in the engine and exhaust system, creating the risk of fire or other damage.
--

 WARNING
--

Do not park, idle, or drive your vehicle in dry grass or other dry ground cover. The emission system heats up the engine compartment and exhaust system, which can start a fire.

If you consistently start your vehicle in subzero temperatures, use an engine block heater (if your vehicle has this option).

Starting Your Contour

Engine Block Heater (If equipped)

Engine block heaters are strongly recommended if you live in a region where temperatures reach -10°F (-23°C) or below. An engine block heater warms the engine coolant, which improves starting, warms up the engine faster, and allows the heater-defrost system to respond quickly.

To turn the heater on, simply plug it into a grounded 110-volt outlet. Ford recommends that you use a 110-volt circuit that is protected by a ground fault circuit interrupter.

⚠ WARNING

To prevent electrical shock, do not use your heater with ungrounded electrical systems or two-pronged (cheater) adapters.
--

For best results, plug the heater in at least three hours before you start your vehicle. Using the heater for longer than three hours will not damage the engine, so you can plug it in at night to start your vehicle the following morning.

If the Engine Cranks but Does Not Start or Does Not Start After a Collision

Fuel Pump Shut-off Switch

If the engine cranks but does not start or does not start after a collision, the fuel pump shut-off switch may have been triggered. The shut-off switch is a device intended to stop the fuel pump when your vehicle has been involved in a substantial jolt.

Once the shut-off switch is triggered, you must reset the switch by hand before you can start your vehicle. The switch is located on the left hand kick panel in the driver's footwell.

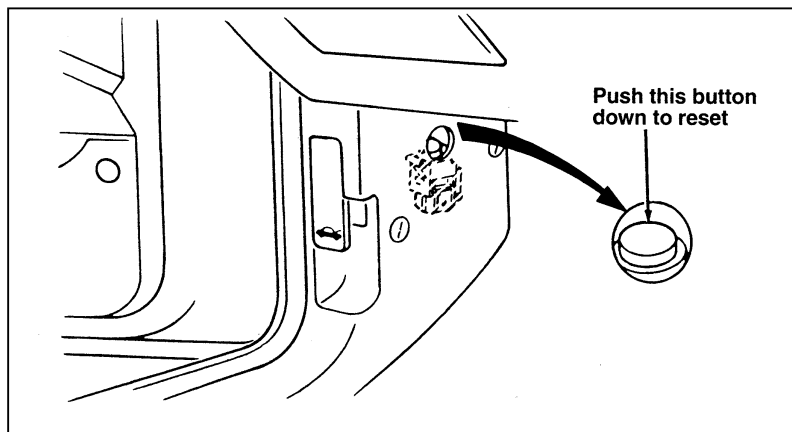

The left-hand kick panel in the driver's footwell

⚠ WARNING

If you see or smell fuel, do not reset the switch or try to start your vehicle. Have all the passengers get out of the vehicle and call the local fire department or a towing service.

Starting Your Contour

If your engine cranks but does not start after a collision or substantial jolt:

1. Turn the ignition key to the OFF position.
2. Check under the vehicle for leaking fuel.
3. If you do not see or smell fuel, push the red reset button down. If the button is already set, you may have a different mechanical problem.
4. Turn the ignition key to the ON position for a few seconds, then turn it to the OFF position.
5. Check under the vehicle again for leaking fuel. **If you see or smell fuel, do not start your vehicle again.** If you do not see or smell fuel, you can try to start your vehicle again.
6. Check all vehicle warning lights before driving the vehicle.

Guarding Against Exhaust Fumes

Carbon monoxide, although colorless and odorless, is present in exhaust fumes. Take precautions to avoid its dangerous effects.

⚠ WARNING

Do not start your vehicle in a closed garage or other enclosed area. Never sit in a stopped vehicle for more than a short period of time with the engine running. Exhaust fumes are toxic. See <i>Guarding Against Exhaust Fumes</i> in this chapter for more instructions.
--

⚠ WARNING

If you smell exhaust fumes inside your vehicle, have your dealer inspect your vehicle immediately. Do not drive if you smell exhaust fumes.
--

Have the exhaust and body ventilation systems checked whenever:

- your vehicle is raised for service
- the sound of the exhaust system changes
- your vehicle has been damaged in a collision

Improve your ventilation by keeping all air inlet vents clear of snow, leaves, and other debris.

If the engine is idling while you are stopped in an open area for long periods of time, open the windows at least one inch (2.5 cm). Also, adjust the heating or air conditioning to bring in outside air.

If you use the heater, set the fan speed on medium or high with the function control knob turned to FLR, PNL/FLR or PANEL.

If you use the air conditioner, set the fan speed on medium or high with the A/C button pressed. (Do not use MAX A/C.)

Warning Lights and Gauges

In your vehicle, the warning lights and gauges are grouped together on the instrument panel. We call this grouping a cluster. Your vehicle has one of the following clusters:

- Standard Cluster
- Sport Cluster

If you are not sure which cluster your vehicle has, check the diagrams on the following pages.

The standard cluster

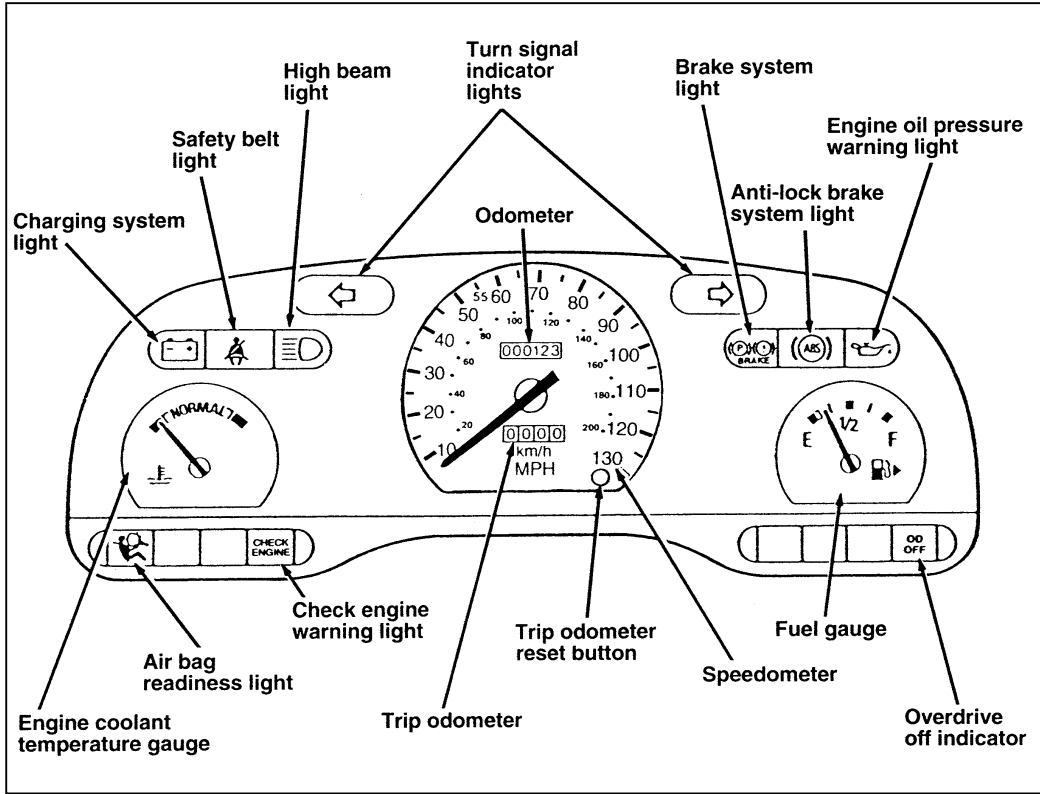

Warning Lights and Gauges

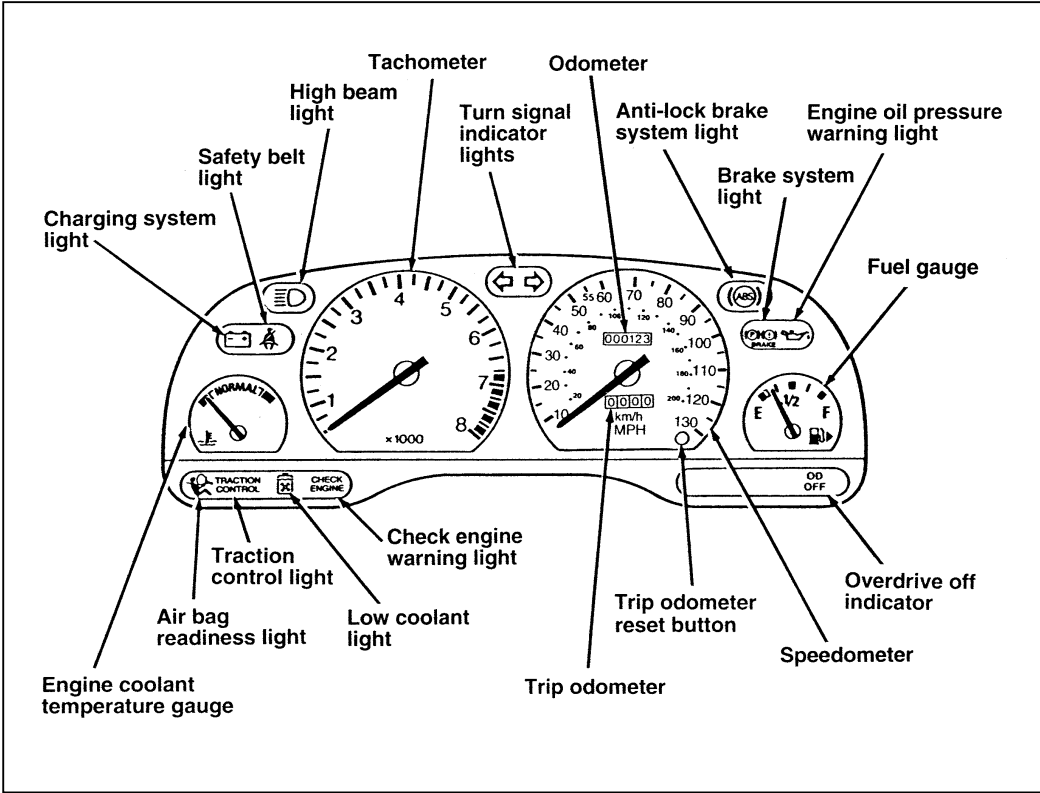

The sport cluster

Standard Cluster

The following warning lights and gauges are on the standard cluster. All of the warning lights and gauges alert you to possible problems with your vehicle. The following sections detail what each of these indicators means.

Indicator Lights and Chimes

Safety Belt Warning Light and Chime

This warning light and chime remind you to fasten your safety belt. The following conditions will take place:

- If the driver's safety belt is not buckled when the ignition is turned to the ON position, the light will turn on for 1 to 2 minutes and the chime will sound for 4 to 8 seconds.
- If the driver's safety belt is buckled while the light is on or the chime is sounding, both the light and the chime will turn off.
- If the driver's safety belt is buckled before the ignition is turned to the ON position, neither the light nor the chime will turn on.



Warning Lights and Gauges

Brake System Warning Light

The warning light for the brakes can show two things — that the parking brake is not fully released, or that the brake fluid level is low in the master cylinder reservoir. If the fluid level is low, the brake system should be checked by a qualified service technician.

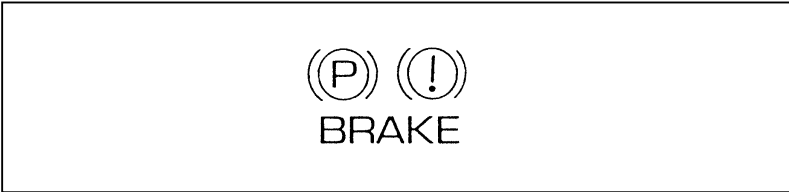

This light comes on when the parking brake is set, or if it is not set, it comes on briefly when you turn the ignition to the START position. It normally goes off shortly after the engine starts and you release the parking brake. If the light stays on after you have fully released the parking brake, have the hydraulic brake system serviced by your dealer or a qualified service technician.

 WARNING

The BRAKE light indicates that the brakes may not be working properly. Have the brakes checked immediately.
--

Charging System Light

This light indicates that your battery is not being charged and that you need to have the electrical system checked.

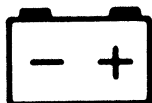

This light comes on every time you turn the ignition to the ON or START position (engine off). The light should go off when the engine starts and the alternator begins to charge.

If the light stays on or comes on when the engine is running, have the electrical system checked as soon as possible.

Engine Oil Pressure Warning Light

This light indicates the engine's oil pressure, not the oil level. However, if your engine's oil level is low, it could affect the oil pressure. The light will come on briefly when you turn your key to the START and ON position. The light should stay off when the engine is running with normal oil pressure. If the light comes on while the engine is running, you have lost oil pressure and continued operation will cause severe engine damage.



Warning Lights and Gauges

If you lose engine oil pressure:

1. Pull off the road as soon as safely possible.
2. Shut off the engine immediately. If you do not stop the engine as soon as safely possible, severe engine damage could result.
3. Check the engine's oil level, following the instructions on checking and adding engine oil in this Owner Guide. (See *Engine oil* in the Index.) If you do not follow these instructions, you or others could be injured. To ensure an accurate reading, your vehicle should be on level ground.
4. If the level is low, add only as much oil as necessary to bring it to the full level before you start the engine again. Do not overfill. Do not operate the engine if the light is on, regardless of the oil level. Contact your nearest dealer for further service actions.

High Beam Light

This light comes on when the headlamps are turned to high beam or when you flash the lights.

If the high beam light flashes in a vehicle equipped with the Daytime Running Light (DRL) system (Canada), it indicates a failure in the DRL circuit. Check the bulbs and fuses or have the DRL system checked by your dealer or a qualified service technician.



Chime for Headlamps On

This chime sounds if the driver's door is open when the parking lamps or headlamps are on. The chime sounds until you close the door or turn off the lamps.

Air Bag Readiness Light

The air bag system uses a readiness light and a tone to indicate the condition of the system. The readiness light is in the instrument cluster. When you turn the ignition to the ON position, this light will illuminate for approximately six (6) seconds and then turn off. This indicates that the system is operating normally. **NOTE:** Maintenance of the air bag system is not required.

A problem with the system is indicated by one or more of the following: the readiness light will either flash or stay lit, or it will not light or a group of five beeps will be heard.

 WARNING
--

<p>If any of these things happen, even intermittently, have the air bag system serviced at your Ford or Lincoln-Mercury dealer immediately.</p>
--



Warning Lights and Gauges

Check Engine Warning Light

The Powertrain On-Board Diagnostic II (OBD II) system consists of the hardware and software necessary to monitor the operation of the powertrain. The OBD II system is designed to check the function of the vehicle's powertrain control system during normal operation. If an emission problem is detected, the Check Engine Warning Light (in the cluster) is turned on.

Modification or additions to the vehicle may cause incorrect operation of the OBD II system. Additions such as burglar alarms, cellular phones, and CB radios must be carefully installed. Do not install these devices by tapping into or running wires close to powertrain control system wires or components.



CHECK
ENGINE

This light comes on briefly when you turn the ignition to the ON position, but should turn off when the engine starts. If the light does not come on when you turn the ignition to the ON position or if it comes on and stays on when you are driving, have your vehicle serviced as soon as possible. This indicates a possible problem with one of the engine's emission control systems. **You do not need to have your vehicle towed in.**

If the light turns on and off at one (1) second intervals while you are driving the vehicle, it means that the engine is misfiring. If this condition persists, damage could occur to the engine or catalytic convertor. Have your vehicle serviced at the first opportunity. You do not need to have your vehicle towed in.

If the light turns on and off on rare occasions while you are driving, it means that a malfunction occurred and the condition corrected itself.

An example of a condition which corrects itself occurs when an engine running out of fuel begins to misfire. In this case, the Check Engine Warning Light may turn on and will then set a Diagnostic Trouble Code indicating that the engine was misfiring while the last of the fuel was being consumed. After refueling, the Check Engine Warning Light will turn off after the vehicle has completed three consecutive warm up cycles without a misfire condition occurring. A warm up cycle consists of engine start from a cold condition (engine at ambient temperature) and running until the engine reaches normal operating temperature.

On the fourth engine start up, the Check Engine Warning Light will turn off as soon as the engine begins to crank. It is not necessary to have the engine serviced.

Under certain conditions, the Check Engine Warning Light may come on if the fuel cap is not properly installed. If the Check Engine Warning Light comes on and you suspect that the fuel cap is not properly installed, pull off the road as soon as it is safely possible and turn off the engine. Remove and replace the fuel cap, making sure it is properly seated.

After completing the three consecutive warm up cycles and on the fourth engine start up, the Check Engine Warning Light should turn off. If the light does not go off after the fourth engine restart, have your vehicle serviced by your dealer or a qualified technician.

Warning Lights and Gauges

Overdrive Off Indicator (Automatic Transaxle Only)

This light tells you that the Transaxle Control Switch (TCS) on the gearshift lever has been pushed. When the light is on, the transaxle will not shift into overdrive. Depressing the TCS button located below the gearshift release button on the shifter will return the vehicle to “overdrive on” mode. The transaxle will be in the “overdrive on” mode when the vehicle is started even if the O/D OFF mode was selected when the vehicle was last shut off.

If the light does not come on when the TCS is depressed or if the light flashes when you are driving, have your vehicle serviced at the first opportunity.



OD
OFF

Turn Signal Indicator Lights

The turn signal arrow will flash to indicate the direction in which you are going to be turning.



Fuel Gauge

The fuel gauge displays approximately how much fuel you have in the fuel tank.

For proper fuel gauge operation, the ignition must be in the OFF position before you add fuel to the fuel tank.

The fuel gauge indicator may vary slightly while the vehicle is in motion. This is the result of fuel movement within the tank. An accurate reading may be obtained with the vehicle on smooth, level ground.

Engine Coolant Temperature Gauge

This gauge indicates the temperature of the engine coolant, not the coolant level. If the coolant is not at its proper level or mixture, the gauge indication will not be accurate.

The pointer moves from the white mark into the NORMAL band as the engine coolant warms up. It is acceptable for the pointer to fluctuate within the NORMAL band under normal driving conditions. Under certain driving conditions, such as heavy stop and go traffic or driving up hills in hot weather, the pointer may indicate at the top of the NORMAL band.

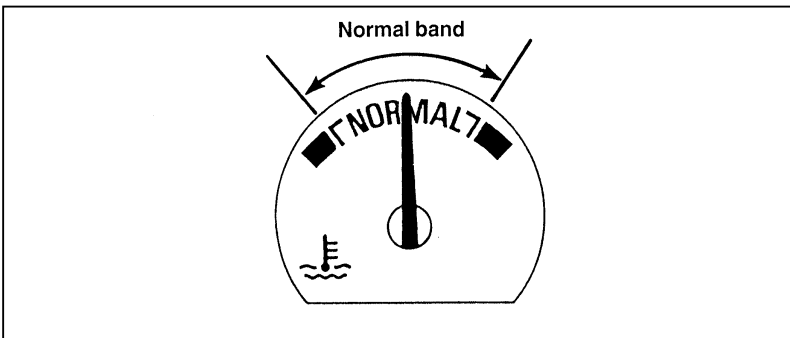

The engine coolant temperature gauge

Warning Lights and Gauges

If, under any circumstances, the pointer moves above the NORMAL band, the engine coolant is overheating and continued operation may cause engine damage.

If your engine coolant overheats:

1. Pull off the road as soon as safely possible.
2. Turn off the engine.
3. Let the engine cool.
4. Check the coolant level following the instructions on checking and adding coolant to your engine, see *Engine Coolant* in the Index. If you do not follow these instructions, you or others could be injured.

If the coolant continues to overheat, have the coolant system serviced as soon as possible.

Speedometer

The speedometer tells you how many miles (kilometers) per hour your vehicle is moving.

Odometer

The odometer tells you the total number of miles (kilometers) your vehicle has been driven.

Trip Odometer

The trip odometer tells you how many miles (kilometers) your vehicle has been driven since the last reset. Press the reset button to return the trip odometer to zero.

Sport Cluster

The sport cluster has basically the same standard warning lights and gauges as the standard cluster, with the following additional features:

Tachometer

The tachometer displays the approximate engine revolutions per minute (rpm), or how fast the engine is running.

If you drive with the tachometer in the red zone, you may damage the engine.

Anti-lock Brake System Warning Light (If equipped)

Your vehicle may have an Anti-lock Brake System feature. If it does, check the Anti-lock Brake System light each time you start the engine. If it stays on longer than three (3) seconds, shut off the engine and restart. If it stays on, that means the Anti-lock Brake feature is not working and should be serviced immediately to restore the benefits of the Anti-lock feature. Normal braking is not affected unless the brake warning light is also lit.

The Anti-Lock Brake System has self-check capabilities. As described above, the system turns on the anti-lock light each time you start your engine. After the engine is started and the anti-lock light turns off, the system performs another test the first time the vehicle reaches 5 mph (8 km/h) (between 12 and 25 mph [20 and 40 km/h] for vehicles equipped with the traction control system). The system turns on the ABS pump motor for approximately 1/2 second. At this time, a mechanical noise may be heard and felt. This is a normal part of the self-check feature. If a malfunction is found during this check the anti-lock light will come on.

Warning Lights and Gauges



Low Coolant Light (If equipped)

This light indicates that the level of the engine coolant is low inside the coolant recovery bottle and that you should add more coolant. See *Engine Coolant* in the Index.



This light comes on for a few seconds when the ignition is turned to the START position, but should turn off when the engine starts. If this light stays on, check the level of coolant inside the recovery bottle. The level may be slightly above the MIN line because the light is an “early warning.”

Traction Control System Light (If equipped)

This light comes on when the traction control system has been disengaged. It may come on or flash on and off while traction control is operating.

If the light stays on for more than three (3) seconds after the ignition is turned to the ON position or does not come on when the T/C OFF button is pressed, have the traction control system checked by a qualified technician as soon as possible.



TRACTION
CONTROL

Instrument Panel Controls

The instrument panel (dashboard) on your vehicle is divided into several different sections. The illustrations on the following pages show the major parts of the instrument panel that are described in this chapter. Some items shown may not be on all vehicles.

The main controls for the climate control system, clock, and radio are on the instrument panel.

Clean the instrument panel lens and woodtone trim with a soft cloth and a glass cleaner. Do not use paper towel or any abrasive cleaner to clean either the lens or the woodtone trim as these may cause scratches.

NOTE: Any cleaner or polish that increases the gloss (shine) of the upper part of the instrument panel should be avoided. The dull finish in this area is to help protect the driver from undesirable windshield reflection.

Instrument panel

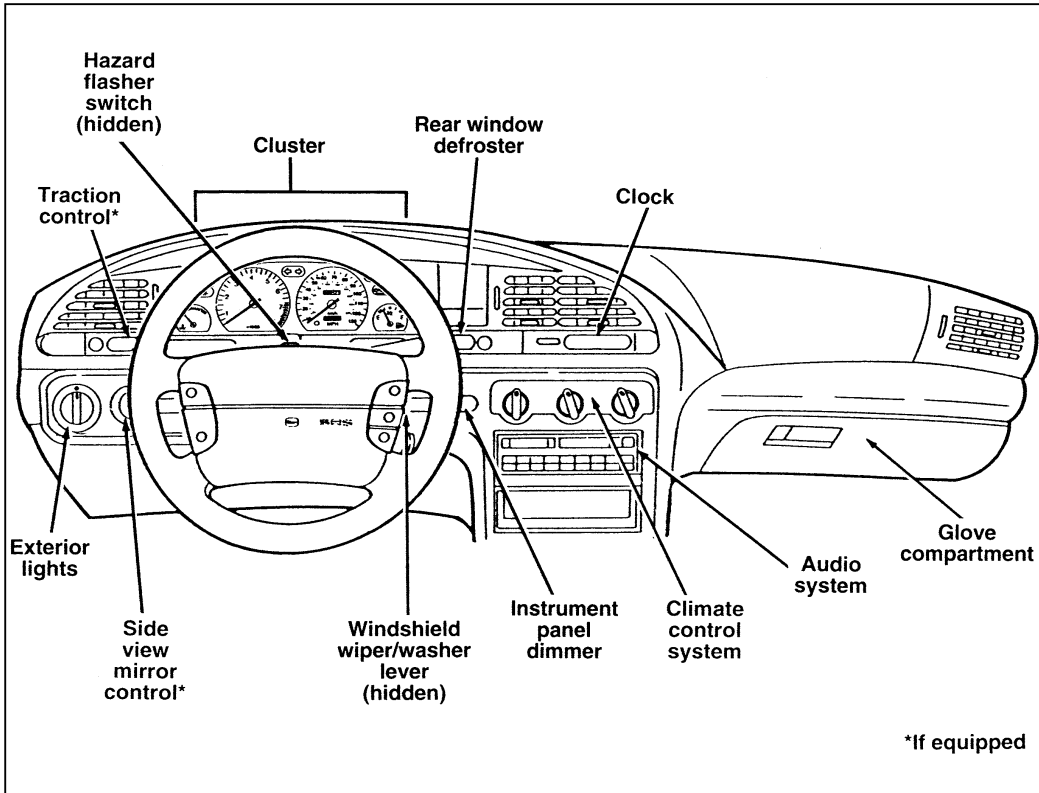

Instrument Panel Controls

The Climate Control Systems

Your vehicle has one of the following:

- Heating Only System (Without Air Conditioning)
- Heating and Air Conditioning System

If you are not sure which system your vehicle has, see the diagrams on the following pages.

Heating Only System

The control for your heater system is located at the center of the instrument panel below the radio. The heater will operate only when the ignition key is turned to the ON position. Your heater will heat and/or ventilate your vehicle interior depending on the function selector knob position and temperature you select. The function selector knob allows you to select heating or ventilation and determine where the air will be directed. The temperature control knob setting determines the temperature of the air that flows into the vehicle.

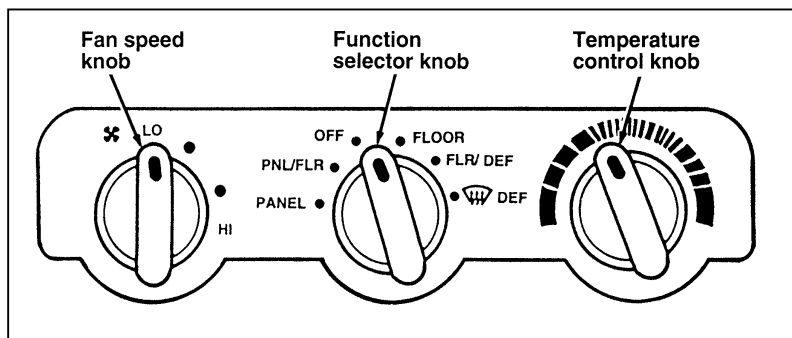



The control for the heating only system

To turn your heater system on, select any position except OFF. This will turn the fan on and allow air flow into the vehicle. To turn your heater off, select OFF. This will turn the fan off and stop air flow from coming into the vehicle.

Your vehicle also has small demister openings on each front door near the window. This allows a small amount of air flow to be directed onto the door glass to reduce fogging whenever the heater system is operating.

The temperature control knob is located at the right side of the control with a broken RED and BLUE band around the top and sides of the knob. The all RED part of the band (full right) is the heat or warmer area. The all BLUE area (full left) is the cool or unheated temperature area. Any position selected between full right and full left will give a temperature between the two extreme temperatures. The cool temperature you select will not be cooler than the outside temperature if your vehicle is not equipped with an air conditioner.

Fan speed adjustment

The  (left) knob on the control is the fan speed knob which controls the volume of air flow. Rotate the  knob to HI to increase fan speed and increase the amount of air entering the vehicle. Four fan speed positions are available and are indicated by LO, two single dots and HI beside the  control knob.

Air flow selections

PANEL

Use PANEL to bring outside air through the instrument panel registers. You can heat the air in this position by rotating the temperature control knob into the RED area. The air CANNOT be cooled below the outside temperature regardless of the temperature control knob setting.

Instrument Panel Controls

PNL/FLR

Select PNL/FLR to get air flow to the floor and through the instrument panel registers at the same time. This selection can be used to either heat or ventilate your vehicle.



FLOOR

Air flow will be to the floor when FLOOR is selected. The air cannot be cooled in the FLOOR position but can be heated by rotating the temperature control knob into the RED area.

FLR/DEF

Select FLR/DEF to get air to the floor and windshield defrosters at the same time.

DEF

Select  DEF to obtain maximum air flow to the windshield. Rotate the temperature control knob into the RED area for the air temperature required to defrost. Rotate the  knob to increase the air flow.

Heating and Air Conditioning System

Heating, ventilation, defrosting and defogging are accomplished in the same way as with the heating only system. See “Heating Only System.”

With the heating and air conditioning system, if the outside temperature is about 50°F (10°C) or warmer, the air will be dehumidified to remove moisture if you select FLR/DEF or  DEF.

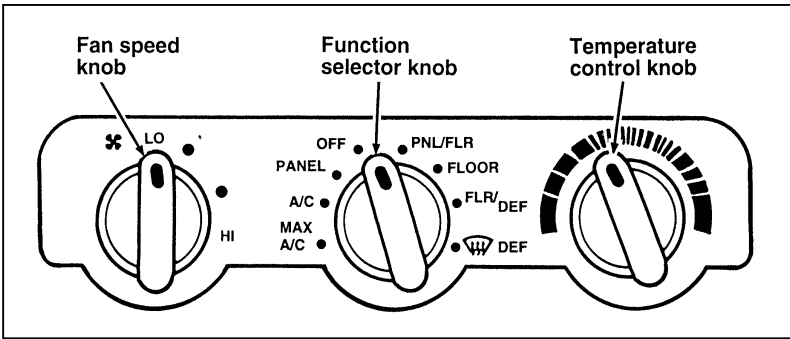

The control for the heating and air conditioning system

Air conditioning

A/C

Select A/C to get refrigerated outside air through the instrument panel registers. The A/C position is used for cooling except when extremely hot or fast cooling of the vehicle is needed. Then, select MAX A/C for fast cooling and return to A/C when you are comfortable.

Instrument Panel Controls

MAX A/C

The MAX A/C position produces cool air more rapidly to provide faster cooling of your vehicle. This is possible because cooler air is drawn from inside the passenger area and refrigerated again instead of using warmer outside air. Using inside air will also make the fan sound louder, which is normal when using MAX A/C. The air flow will be from the instrument panel registers.

Comfort tips

The following tips will help you to get the most satisfaction from your climate control system.

- In humid weather, select  DEF before starting your engine. This will help to prevent windshield fogging. After a few minutes of operation, you may select another function.
- To prevent humidity buildup inside your vehicle, always drive with the climate control system turned on.
- Do not put objects under the front seats that interfere with the flow of air to the back seat area.
- Remove any snow, ice, or leaves from the air intake area of your heater and air conditioner system which could block the air intake. The intake area is located at the bottom of the windshield.

Passenger Compartment Air Filter

Your vehicle may have an air filter that removes pollen and road dust from outside air before it is directed to the interior of the vehicle. For maintenance of this filter, see *Servicing Your Contour*.

Rear Window Defroster and Heated Side View Mirrors (If equipped)

The defroster for the rear window clears frost, fog, or thin ice from both the inside and outside of the rear window and activates the heated side view mirrors.

The button for the rear window defroster and heated side view mirrors is on the instrument panel, to the right of the steering wheel.

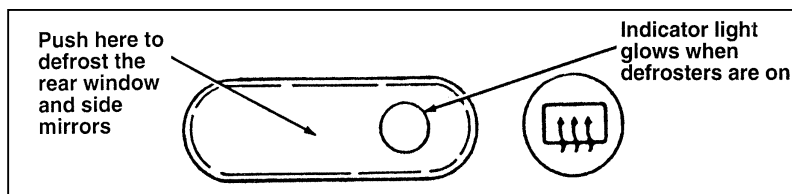

The rear window defroster and heated side view mirrors

Clear away any snow that is on the rear window and side view mirrors before using the defroster. With the engine running, push the defroster button.

After approximately 10 minutes, the defroster will turn off. If the window or mirrors are still not clear, turn the defroster on again.

The defroster will turn off when the ignition key is turned to the OFF or START position.

NOTE: Never use sharp instruments or window cleaners with abrasives to clean the inside of your rear window. If you do, you may damage the heating elements that are bonded to the inside of the rear window and cause damage to the rear window defroster.

Instrument Panel Controls

The Interior and Exterior Lights

Turning On the Exterior Lights

To turn on your headlamps, parking lamps, and tail lamps, use the knob that is on the instrument panel, to the left of the steering wheel.

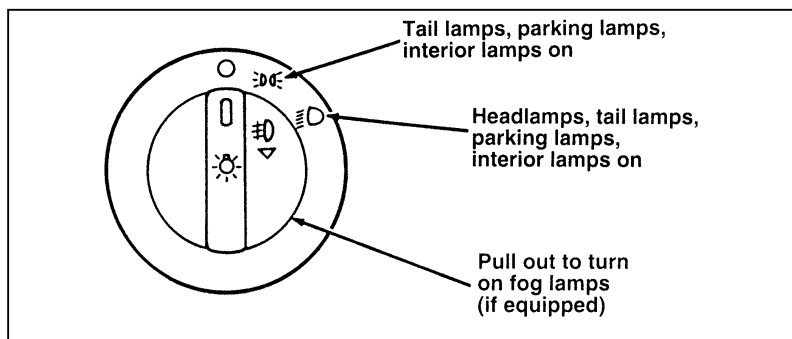

The knob for the exterior lights

To turn on the parking lamps and tail lamps, turn the knob clockwise to the first position.

To turn on the headlamps, parking lamps and tail lamps, turn the knob clockwise to the second position.

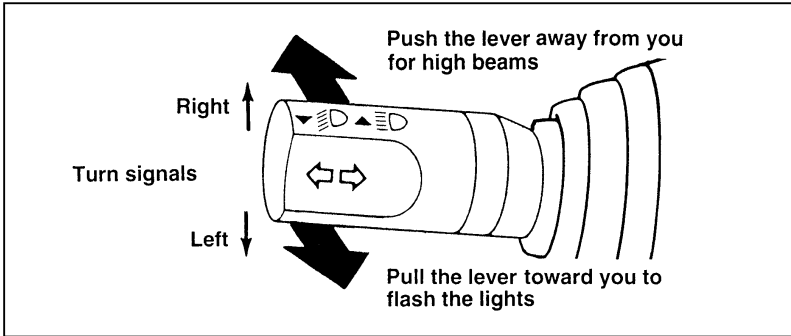

Turning on the high beams

To change the headlamps from low to high beam, push the lever away from you until it latches, and release. The high beam indicator in the instrument cluster glows when the headlamps are on high beam. To change the headlamps from high beam to low beam, pull the lever toward you until it latches.

Fog Lamps (If equipped)

The fog lamps act as a supplement to the low beam headlamps under limited visibility conditions such as rain, snow, dust or fog.

The fog lamps operate only when the low beam headlamps are on. To operate the fog lamps, turn the headlamp control knob to the second position (headlamps on) and pull the knob out. An indicator lamp will glow when the fog lamps are on.

To turn off, push the headlamp control knob in.

To maximize fog lamp bulb life it is recommended that the fog lamp switch be turned off after each use prior to turning off the headlamps.

Instrument Panel Controls

Daytime Running Light System

(Canadian vehicles only)

The Daytime Running Light (DRL) system is designed to turn the high beam headlamps on, with a reduced light output and without illuminating the high beam indicator lamp in the instrument panel. The DRL system operates when all of the following conditions are met:

- The vehicle is “running.”
- The headlamp system is in the OFF position.

The high beam indicator light on the instrument cluster will not be on.

A flashing high beam light in the instrument cluster indicates a failure in the DRL system circuit, like a burnt bulb or fuse.

 WARNING
--

<p>The Daytime Running Light (DRL) system will not illuminate the tail lamps and parking lamps. Turn on your headlamps at dusk. Failure to do so may result in a collision.</p>
--

Cleaning the Exterior Lamps

Do not use dry paper towel, chemical solvents or abrasive cleaners to clean the lamps, as these may cause scratches or crack the lamps.

Lighting Up the Interior and Instrument Panel

When either front door is opened, the footwell lights and the door courtesy lights come on.

The instrument panel lights, window control lights and door handle lights come on whenever the headlamp switch is turned from the OFF position. To dim the instrument panel lights, use the thumbwheel on the instrument panel to the right of the steering wheel.

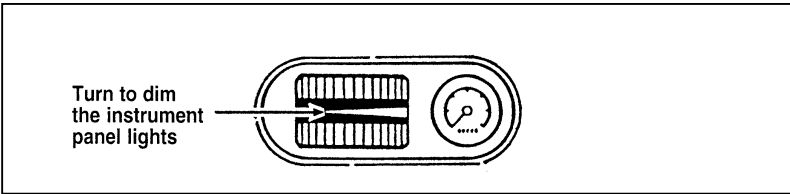

Dimming the instrument panel lights

Dome Lamp

Your vehicle has a dome lamp above the front seat. The switch on the dome lamp turns it on and off.

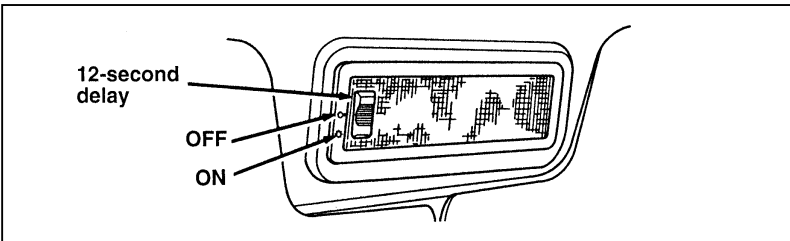

The switch on the dome lamp

Instrument Panel Controls

Dome lamp delay

Your vehicle may have a dome lamp delay. If you set the switch on the dome lamp to the 12-second delay position, the dome lamp will turn on when either front door is opened.

The dome lamp will turn off after 12 seconds or when the ignition key is turned to the ON or ACC position. It will not turn off if either front door is open or if you move the dome lamp switch to the ON position.

Your interior dome lamps and map lamps are plastic and should be cleaned with a mild detergent diluted in water. Rinse them with clear water.

Turning On the Map Lamps (If equipped)

Your vehicle may have a map lamp for the passenger and one for the driver.

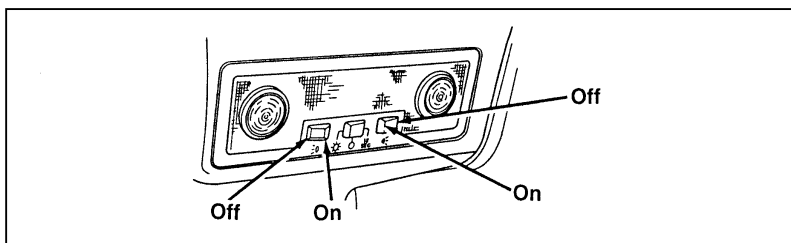

Turning on the map lamps

Traction Control System (If equipped)

This button turns the traction control system off and on. See *Driving Your Vehicle* for more information.



The button for the traction control system

Clock

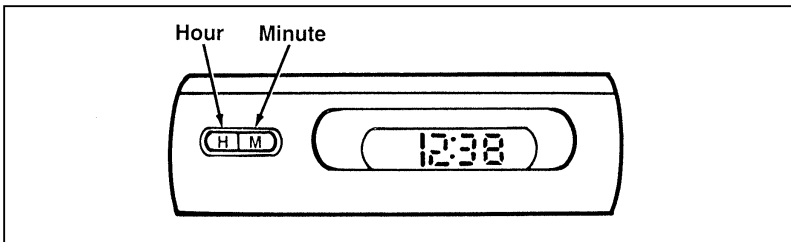

The digital clock

1. To set the hour, press and hold the hour button. When the desired hour appears, release the button.
2. To set the minutes, press and hold the minute button. When the desired minute appears, release the button.
3. To switch between a 12-hour clock and a 24-hour clock, press both the hour and minute buttons at the same time. Reset the time as above.

Steering Column Controls

The controls on the steering column and wheel are designed to give you easy access to the controls while you are driving.

The Turn Signal Lever

You can use the turn signal lever on the left side of the steering column to:

- operate the turn signals and cornering lamps
- turn the high beams on/off
- flash the lamps

Turn Signals

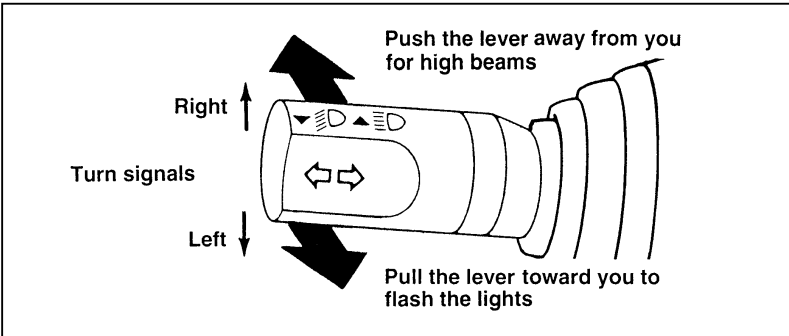

The turn signal lever

Move the lever up to signal a right turn. Move it down to signal a left turn. The corresponding indicator light in the instrument cluster will flash.

If the turn signal stays on after you turn, move the lever back to the center (off) position.

For lane changes, move the lever far enough to signal but not to latch. The lever will return to the off position when you release it.

High Beams and Flashing the Lamps

To turn on the high beams, turn the headlamp control knob to the headlamp ON position and push the turn signal lever away from you until it latches. When the high beams are on, the high beam indicator light on the instrument cluster comes on.

To turn off the high beams, pull the lever back to the off position.

To flash the headlamps, pull the lever toward you for a moment and then release it. The headlamps will flash whether the headlamp knob is in the on or off position.

Windshield Wipers and Washer

To turn on the windshield wipers, the ignition key must be turned to the ON or ACC position.

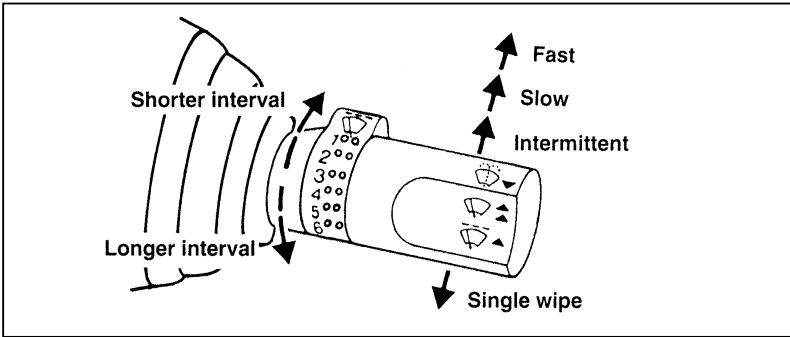

Using the windshield wiper

The windshield wipers can be set on high, low speed or interval wipe. Turn the ring on the lever to set a longer or shorter pause between wiping cycles.

Steering Column Controls

Windshield Washer

When the lever is pulled to activate the windshield washer, the wipers operate for about three cycles after the spray stops.

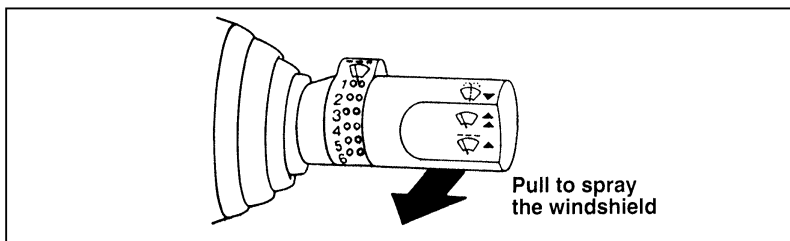

Washing the windshield

Do not try to clean the windshield when the washer fluid container is empty or activate the washers at any time for more than 15 seconds continuously. This could damage the washer pump system.

⚠ WARNING

In freezing weather, the washer solution may freeze on the windshield and obscure your vision. Always warm up the windshield with the defroster before you use the washer fluid. If you cannot see through the windshield clearly, it can increase the risk of being involved in a collision.

For information about refilling the washer fluid or replacing your windshield wiper blades, see *Windshield washer fluid and Wipers* in the Index.

Hazard Flasher

The hazard flasher serves as a warning to other drivers to be careful when approaching or passing your vehicle.

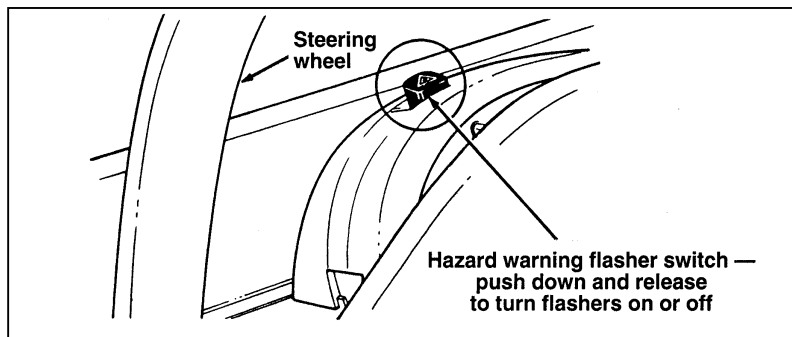

Using the hazard flasher switch

The flashers work whether your vehicle is running or not. The flashers work for up to two hours when the battery is fully charged and in good condition without draining the battery excessively. If the flashers run for longer than two hours or if the battery is not fully charged, the battery can be drained.

Horn

To sound the horn, push the pad in the center of the steering wheel. Check the horn regularly to be sure it operates properly.

Steering Column Controls

Speed Control (If equipped)

If your vehicle has speed control, you can automatically maintain a constant speed at or above 30 mph (50 km/h).

Use of radio transmitting equipment that is not Federal Communications Commission (FCC) or in Canada the Canadian Radio and Telecommunications Commission (CRTC) approved may cause the speed control to malfunction. Therefore, use only properly installed FCC (CRTC in Canada) approved radio transmitting equipment in your vehicle.

NOTE: Do not shift to N (Neutral) when using the speed control. This will cause the engine to overspeed.

 WARNING
--

Do not use the speed control in heavy traffic or on roads that are winding, slippery, or unpaved.
--

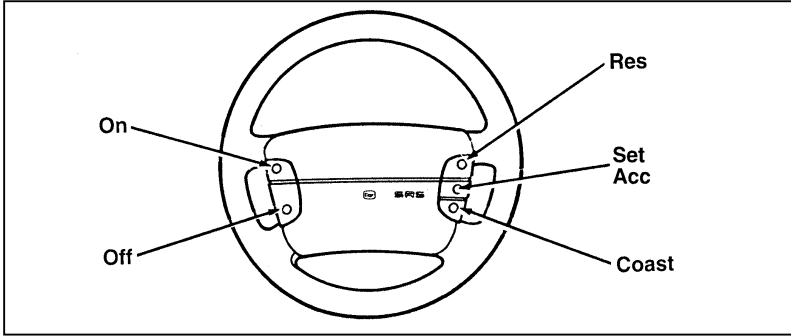

The speed control switches on the steering wheel

Setting the speed control

1. Press and release the ON switch.
2. Accelerate to the desired speed above 30 mph (50 km/h) using the accelerator pedal.
3. Press the SET ACC switch and release it immediately to set your speed. If you keep this switch depressed, your speed will continue to increase.
4. Take your foot off the accelerator pedal. Your vehicle will maintain the speed you set.

Steering Column Controls

If you drive up or down a steep hill, your vehicle may momentarily slow down or speed up, even though the speed control is on. This is normal.

NOTE: If your vehicle is equipped with an automatic transaxle, and if your speed increases above your set speed while driving in Overdrive on a downhill grade, you may want to turn the Overdrive off and use Drive. You may turn the Overdrive off by pressing the Transaxle Control Switch on the left side of the gearshift lever. This will reduce vehicle speed if it goes above your set speed on a downhill grade. For the best fuel economy during normal driving conditions, leave the vehicle in Overdrive, or resume as soon as possible.

NOTE: If your vehicle is equipped with a 5-speed manual transaxle, and if your speed increases above your set speed while driving in 5 (Fifth) gear on a downhill grade, you may want to shift to 4 (Fourth) gear to reduce vehicle speed. Depressing the clutch pedal cancels speed control, therefore speed control must be reset by pressing the SET/ACC or RES buttons. Speed control cannot reduce the vehicle speed if it goes above your set speed on a downhill grade.

Speed control is cancelled when Traction Control (if equipped) becomes active.

Accelerating With the Speed Control Operating

You can use the accelerator pedal to speed up momentarily. When you take your foot off the accelerator, the vehicle will return to the set speed.

Resetting the Speed Control

To reset the speed control to a **lower speed**, use one of the following procedures:

- **COAST** — Press and hold the COAST switch. Release the switch when the vehicle slows down to the desired speed.
- Tap the brake pedal. When the vehicle attains the desired speed, press the SET ACC switch and release it immediately.
- **TAP-DOWN** — Press and then quickly release the COAST switch. Each time you “tap” the switch, the set speed will decrease by 1 mph (1.6 km/h).

If vehicle speed is reduced below 30 mph (50 km/h) by any of the above methods, then you must manually accelerate to a speed over 30 mph (50 km/h) and reset the system.

To reset the speed control to a **higher speed**, follow one of these procedures:

- **ACC** — Press and hold the SET ACC switch. Release the switch when the vehicle has accelerated to the desired speed.
- Depress the accelerator pedal. When the vehicle attains the desired speed, press and release the SET ACC switch.
- **TAP-UP** — Press and then quickly release the SET ACC switch. Each time you “tap” the switch, the set speed will increase by 1 mph (1.6 km/h).

Steering Column Controls

To Cancel Speed Control

Speed control can be cancelled at any time by pressing the brake pedal slightly. After cancelling, you can return to the speed you set by pressing the RES switch, or set a new speed by pressing the SET ACC or COAST switch.

Cancelling and Resuming a Set Speed

If you press the brake pedal, the speed control is suspended. You can return to the set speed by pressing the RES switch, as long as you did not press the OFF switch. You must be driving at least 30 mph (50 km/h).

Your vehicle will gradually return to the previously set speed and then maintain it.

To Turn Off the Speed Control System

Press the OFF switch.

In addition, the speed control is turned off each time you turn the vehicle off.

Your vehicle has a variety of features designed for your comfort, convenience and safety. Read this chapter to find out about standard and optional features.

Doors

Childproof Locks for the Rear Doors

In addition to standard or power locks, your vehicle has childproof locks for the rear doors. If you set these locks, the rear doors cannot be opened from the inside of the vehicle. The doors can still be opened from the outside if the doors are unlocked.

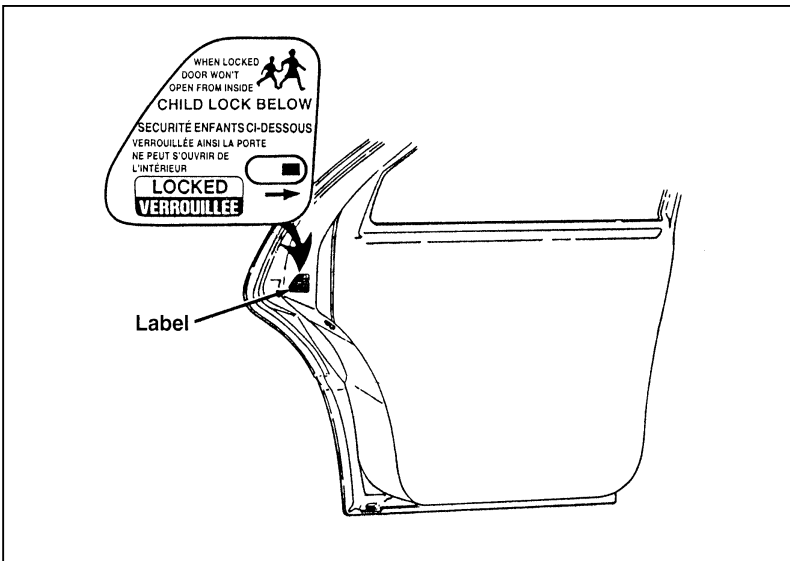

The childproof locks for the rear door

To set the childproof lock on each rear door, open the rear door.

Find the lever at the black label with word LOCKED in white letters. Move the lever toward the inside of the door.

To release the childproof lock, open the rear door from the outside.

Move the lever toward the outside of the door.

Power Door Locks (If equipped)

If your vehicle has power door locks, the controls to lock the doors are on the trim panel of the front door. When you close the doors after you set the door locks, the doors remain locked. If the power mechanism fails, the manual door lock will automatically override the power controls.

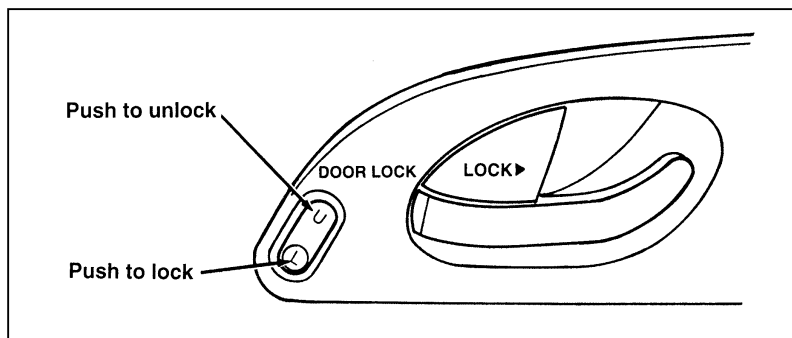

The power door lock on the driver's door

Using the Illuminated Entry System (If equipped)

If your vehicle is equipped with the illuminated entry system, the interior lights turn on when you lift the outside door handle on either front door.

These lights automatically turn off after 12 seconds or when you turn the ignition key to ON or ACC. The inside lights will not

Features

turn off if you have turned them on with the switch in the dome lamp or if the front door is open.

Remote Entry System (If equipped)

If your vehicle has the remote entry system, you can lock and unlock the vehicle doors and open the trunk without using a key. The remote also has a personal alarm feature. The buttons for the system are located on the hand held transmitter(s) that came with your vehicle.

The system will work with up to four transmitters. Additional transmitters can be ordered from your dealer.

The remote entry features only operate with the ignition in the OFF position.

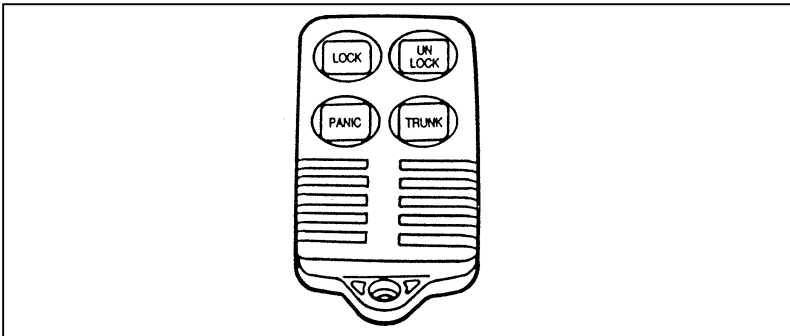

Remote entry transmitter

Unlocking the doors and opening the trunk

To unlock the driver's door, press the UNLOCK button.

To unlock the other doors, press the UNLOCK button a second time within five seconds of unlocking the driver's door.

To open the trunk, press the TRUNK button.

When you use the remote entry UNLOCK, TRUNK or PANIC buttons, the illuminated entry system turns on the interior lights for 12 seconds. You can turn these lights off by turning the ignition to the ON position. The interior lights will not turn off if you have turned them on manually or if a door is open.

NOTE: The illuminated entry system will only work when the dome light switch is in the “12” position.

Locking the doors

To lock all the doors, press the LOCK button.

If you would like a signal that the doors are being locked, press the LOCK button again within five seconds. The doors will lock again, the horn will beep and the low beam headlamps and tail lamps will flash.

Activating the remote personal alarm

If you wish to activate the remote personal alarm, press the PANIC button. This will honk the horn and flash the low beam headlamps and tail lamps for approximately two minutes forty-five seconds. You can turn it off by pressing the PANIC button again on the same transmitter or by turning the ignition key to the ON position.

Replacing the batteries

The remote entry transmitter is powered by two coin type three-volt lithium 2016 batteries (included) that should last for several years of normal use. If you notice a significant decrease in operating range, the batteries should be replaced. Replacement batteries can be purchased at most pharmacies, watch stores or at your Ford or Lincoln-Mercury dealer.

Features

NOTE: The operating range of the remote entry system can also be affected by weather conditions (such as very cold temperatures) or structures around the vehicle (buildings, other vehicles, radio towers, etc.). Typical operating range will allow you to be up to 33 feet (10 meters) away from your vehicle.

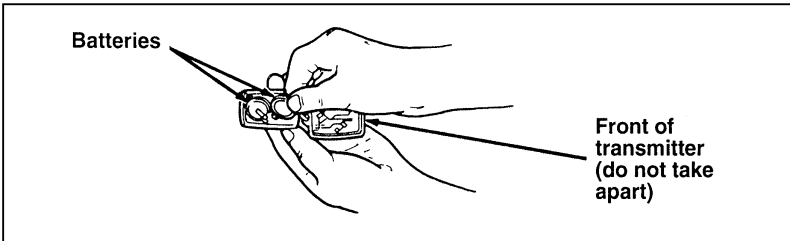

Replacing the batteries

The transmitter can be snapped apart to replace the batteries by twisting a thin coin between the two halves of the transmitter. **DO NOT TAKE THE FRONT PART OF THE TRANSMITTER APART.** When installing the new batteries, be sure to place the positive (+) side down as marked. Snap the two halves back together.

Replacement/additional transmitters

In the event a transmitter is lost, return the remaining transmitters to your dealer for reprogramming of your remote entry system. This is necessary to prevent further unauthorized use of the lost transmitter.

Additional transmitters may be purchased from your dealer (remote entry system will work with up to four transmitters). Return your existing transmitters to your dealer so the remote entry system can be reprogrammed with your new and existing transmitters.

THIS DEVICE COMPLIES WITH PART 15 OF THE FCC RULES. OPERATION IS SUBJECT TO THE FOLLOWING TWO CONDITIONS: (1) THIS DEVICE MAY NOT CAUSE HARMFUL INTERFERENCE, AND (2) THIS DEVICE MUST ACCEPT ANY INTERFERENCE RECEIVED, INCLUDING INTERFERENCE THAT MAY CAUSE UNDESIRABLE OPERATION.

Windows

Power Windows (If equipped)

Each door has a power control that opens and closes the window on that door. The driver's door has a master control panel that operates all four windows.

In order to use your power window controls, the ignition switch must be in the ON position.

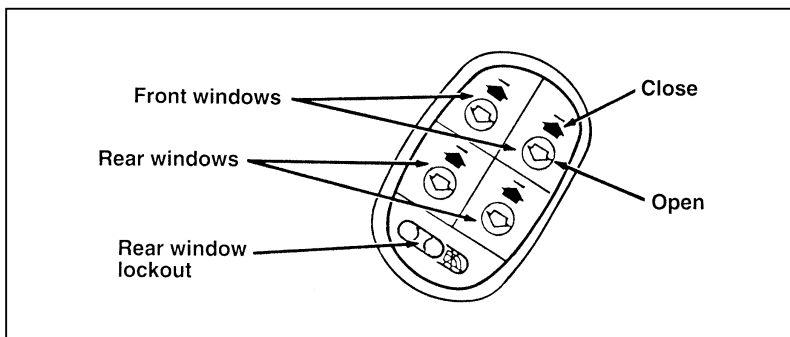

The master controls on the driver's door

Features

 WARNING
--

<p>Do not let children play with the power windows. They may seriously hurt themselves. Make sure occupants are clear of the window(s) before closing.</p>

One-touch-down window

The one-touch-down feature allows you to completely open the driver's window by briefly pressing and releasing the bottom of the window switch. To stop the window before it opens completely, press the switch again.

The one-touch feature only opens the window. To close the window, you must press and hold the top of the switch.

Rear window lockout

To lock out the rear window switches with the master controls, slide the lockout switch to the left. To restore individual control, slide the switch to the right.

Moon Roof (If equipped)

You can move the moon roof back to open the glass panel, or you can tilt it up to ventilate the vehicle.

The rocker type switch is used to open and close the moon roof. You must press and hold the switch until the desired position is reached. At open and closed positions, the motor will automatically turn off. Release the switch at this time to avoid motor damage.

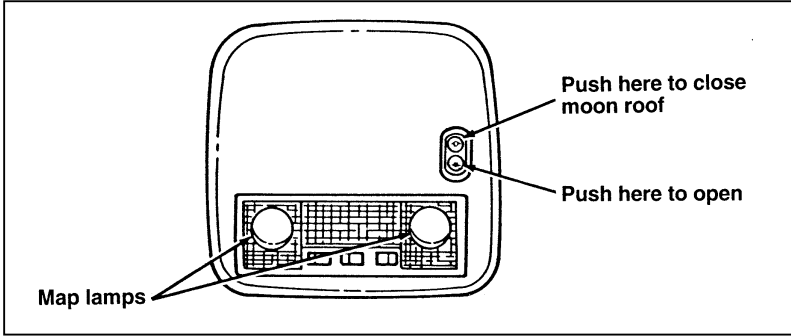

The map lamps and the switch for the moon roof

To open the moon roof, press and hold the rear portion of the switch. The glass panel will move to the open position and stop.

To close the moon roof, press and hold the front portion of the switch. The glass panel will move to the closed position and stop.

To tilt the moon roof into vent position when the glass panel is closed, press the front portion of the switch.

To close from vent position, press and hold the rear portion of the switch.

Occasionally wiping the outside guide rail covers of the moon roof with a clean cloth will help keep the moon roof working properly.

Features

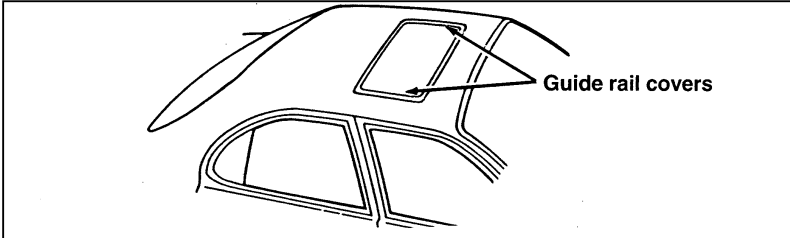

The moon roof

⚠ WARNING

<p>Do not let children play with the moon roof. They may seriously hurt themselves.</p>
--

Sliding Shade

The moon roof has a sliding shade that you can manually open or close to block the sun when the glass panel is shut.

To close the sliding shade, pull the shade toward the front of the vehicle. The shade automatically opens when the moon roof is opened.

Seats

Head Restraints

If you use them properly, head restraints will help protect your head and neck in a collision.

A head restraint helps protect you best if you position it behind your head and not behind your neck.

If your vehicle has the four-way head restraint, you can adjust it in four directions. You can raise it two (2) inches (50 mm) from its normal position, or you can move it forward up to 60° until you reach the desired position.

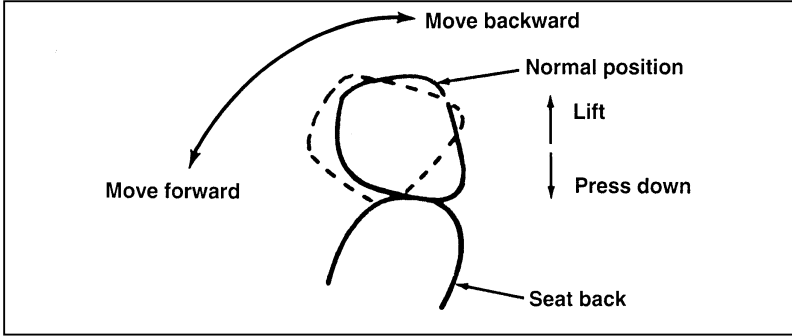

The four-way head restraint

Manual Seats

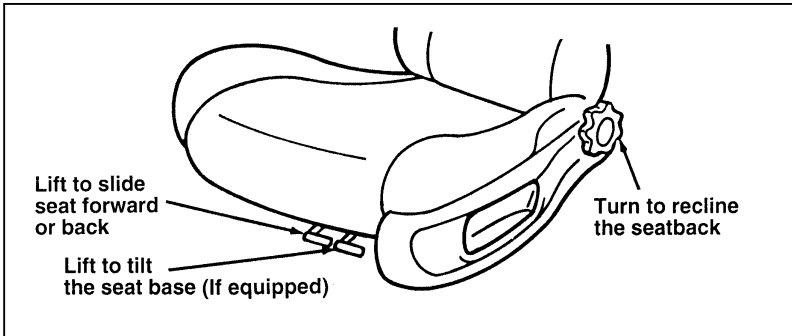

Manual seat adjustment

⚠ WARNING

Never adjust the driver's seat or seatback when the vehicle is moving.

Features

⚠ WARNING

To reduce the risk of serious injury in a collision, always drive and ride with your seatback upright and the lap belt snug and low across the hips.

⚠ WARNING

Do not pile cargo higher than the seatbacks to avoid injuring people in a collision or sudden stop.

Manual lumbar support (If equipped)

The handwheel on the side of the seatback inflates and deflates the lumbar support pads. To inflate the pads, turn the wheel counter-clockwise. To deflate the pads, turn the wheel clockwise.

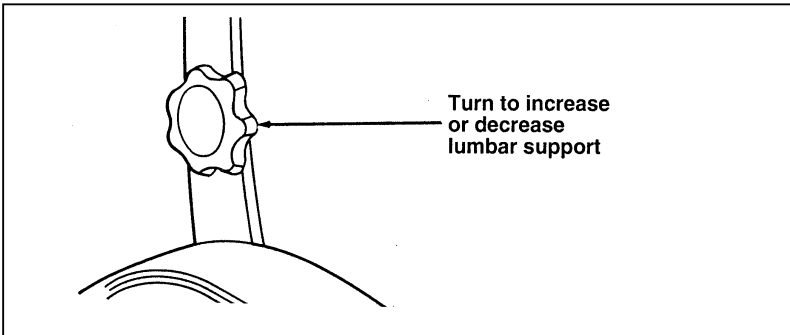

Manual lumbar support adjustment

Power Seats (If equipped)

If your vehicle has power seats, you can raise or lower the whole front seat, move the seat forward or backward and tilt the front or back of the seat up or down.

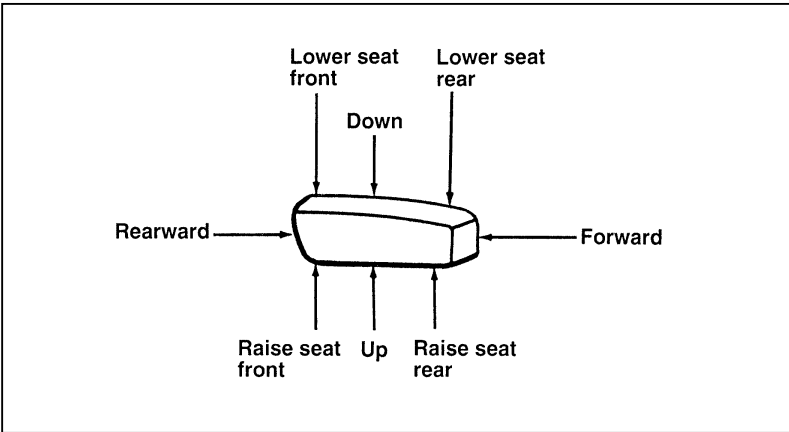

The seat base controls on the driver's seat

To move the seat forward or back, slide the seat base control button forward or back. To raise or lower the height of the seat base, slide the button up or down. To raise or lower the front of the seat base, slide the front of the button up or down. To raise or lower the rear of the seat base, slide the back of the button up or down.

Features

Power seatback (if equipped)

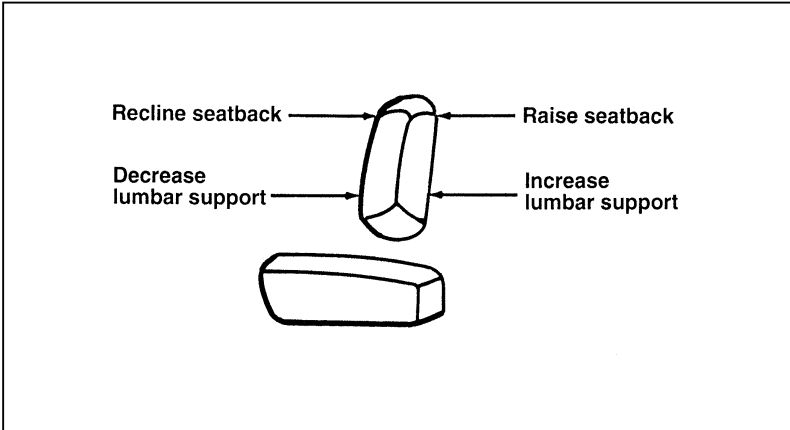

The seatback controls on the driver's seat

To tilt the seatback forward or back, slide the top part of the top button forward or back. To inflate or deflate the lumbar support pads, slide the bottom of the button forward or back.

Folding Rear Seats (If equipped)

The release knobs for the split rear folding seatbacks are in the trunk. Pull the knob to fold down the seat.

To raise the rear seatback, push the seatback upward until it locks in place. Make sure it is firmly latched by pushing forward and back on it.

⚠ WARNING

Securely latch the seatback in the upright position to prevent the seatback or objects from being thrown forward during a sudden stop or collision.

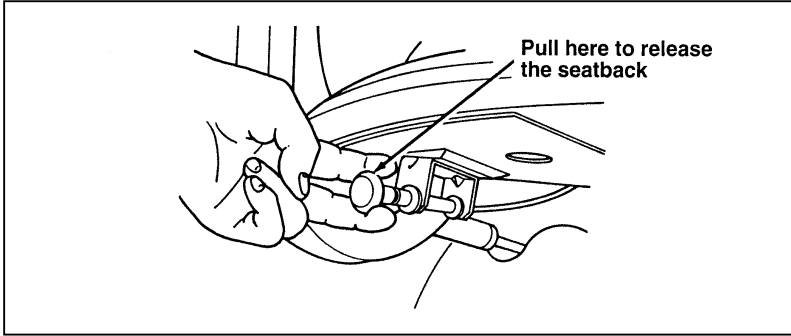

Folding rear seatback release knob

Cleaning the Seats

Leather

For routine cleaning, wipe the surface with a soft, damp cloth. For more thorough cleaning, wipe the surface with a leather and vinyl cleaner or a mild soap.

Fabric

Remove dust and loose dirt with a whisk broom or a vacuum cleaner. Remove fresh spots immediately. Follow the directions that come with the cleaner.

NOTE: Before using any cleaner, test it on a small, hidden area of fabric. If the fabric's color or texture is adversely affected by a particular cleaner, do not use it.

Mirrors

Side View Mirrors

The standard side view mirrors are manually adjusted by using the remote knobs. The knob on each door adjusts the mirror on that side of the vehicle. Move the control knob in the direction you want to move the mirror.

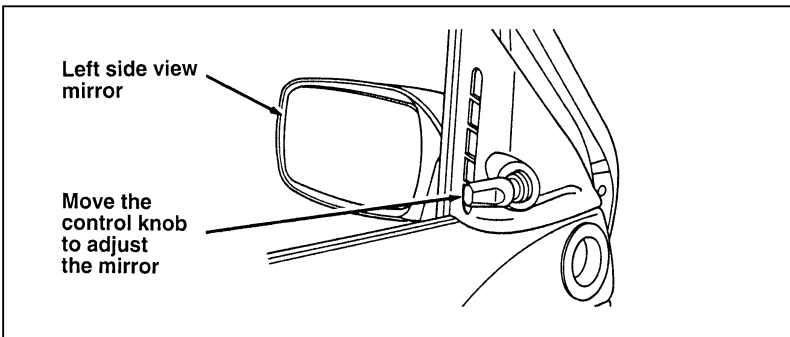

The left side mirror control (right side similar)

Dual electric remote control mirrors (if equipped)

The control for adjusting the electric side view mirrors is on the instrument panel, to the left of the steering wheel.

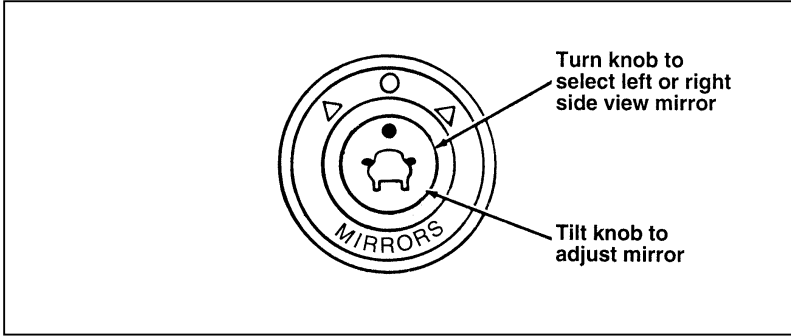

Electric remote control mirror knob

Turn the knob back to the middle position to keep the mirror in place.

The side view mirror on the right is a convex mirror. This mirror gives you a wider view of the lanes on your right and behind you.

⚠ WARNING

The side view mirror on the right makes objects appear smaller and farther away than they actually are.

Do not clean the housing or glass of any mirror with harsh abrasives, fuel or other petroleum-based cleaning products.

Heated mirror feature (If equipped)

Both mirrors are heated whenever the Electric Rear Window Defroster is turned on. Do not remove ice from the mirrors with a scraper or you could damage them. If the outside mirror glass is frozen in place, do not attempt to readjust or move the mirror glass or damage may result.

Sun Visors

Illuminated Visor Mirror (If equipped)

Your vehicle may have lighted mirrors on the sun visors. The mirror is lit by sliding open the mirror cover.

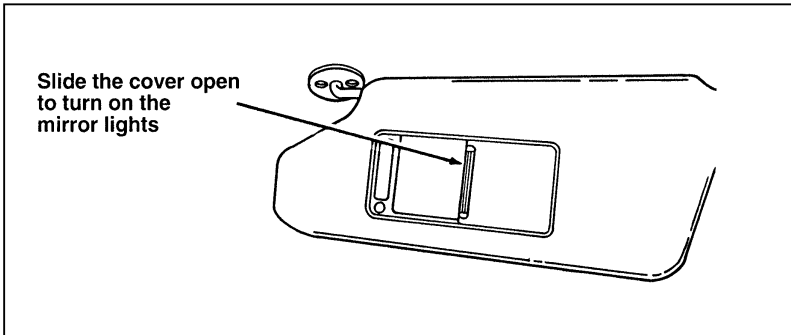

The visor mirror

Console

Your vehicle may have a full console. The full console has the following features:

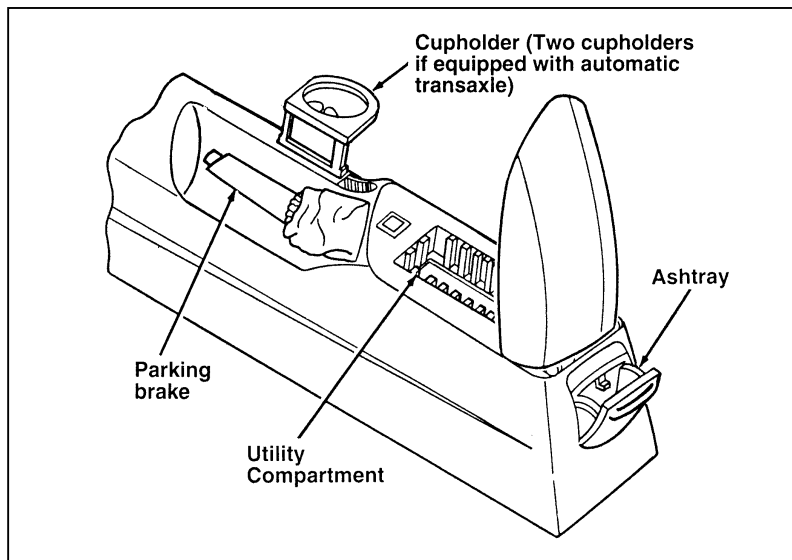

The features on the full console

Cupholder with Full Console

To raise the pop-up cup holder, push and release the cupholder door, then unfold the holder.

Storage Compartments

Your vehicle may have several storage compartments:

- two map pockets on the panels of the front doors. The back of the front seats may also have map pockets.
- a coin holder on the instrument panel
- a small storage pocket on the outside of the front seat base

Trunk

To open the trunk manually, use the oval key.

Remote Trunk Release (If equipped)

The remote trunk release is on the floor to the left of the driver's seat.

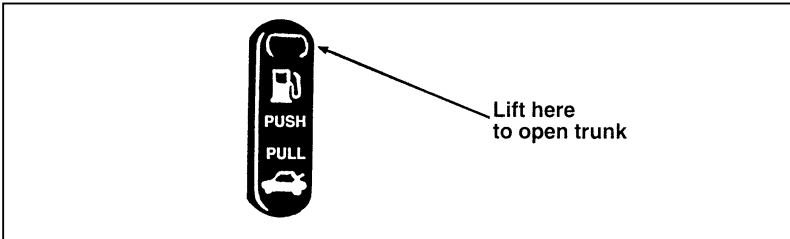

The remote trunk release

You can disable the remote trunk release. If you depress the lever on the trunk latch that is marked in orange before closing the trunk, the trunk can only be opened with the key.

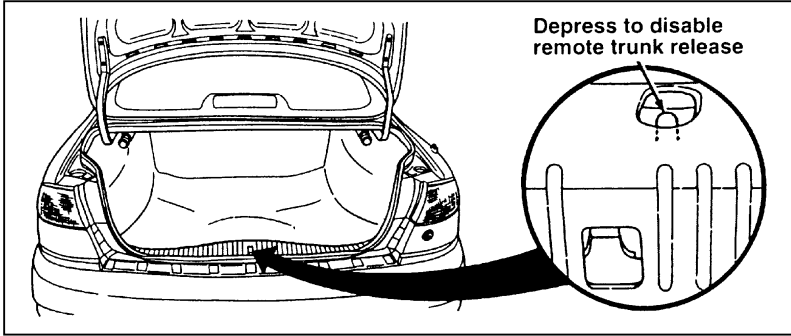

Disabling the remote trunk release

Remote Fuel Filler Door Release (If equipped)

Your vehicle has a remote control fuel filler door which cannot be opened from the outside. To unlatch the fuel filler door, firmly push down the front of the release handle, which is on the floor to the left of the driver's seat. Refer to *Servicing Your Vehicle* in the Index for further information.

Floor Mats

Positive retention floor mat (If equipped) (Standard in Canada)

Position the floor mat in the footwell. Place the mat eyelet over the pointed end of the retention post from the rear and rotate forward to install. Adjust the floor mat position to allow proper operation of accelerator pedal, brake pedal and clutch pedal.

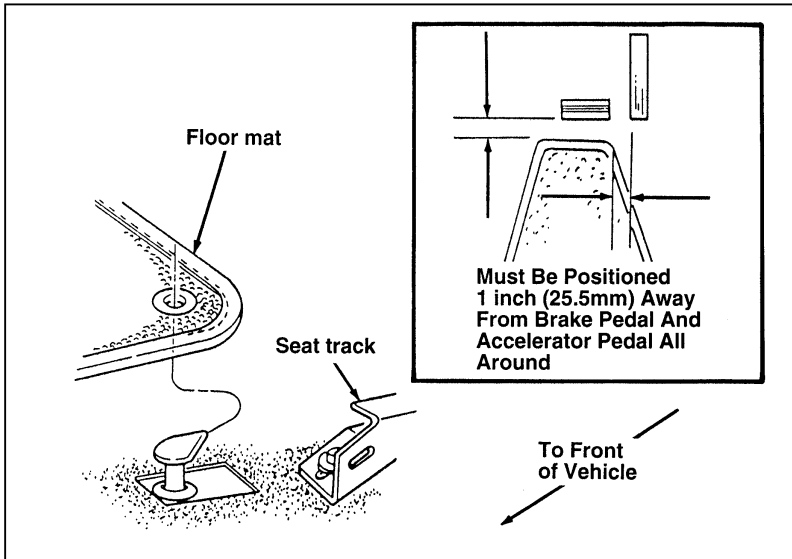

The positive retention floor mat

To remove, lift the floor mat just forward of the retention post and rotate it rearward to disengage it from the retention post.

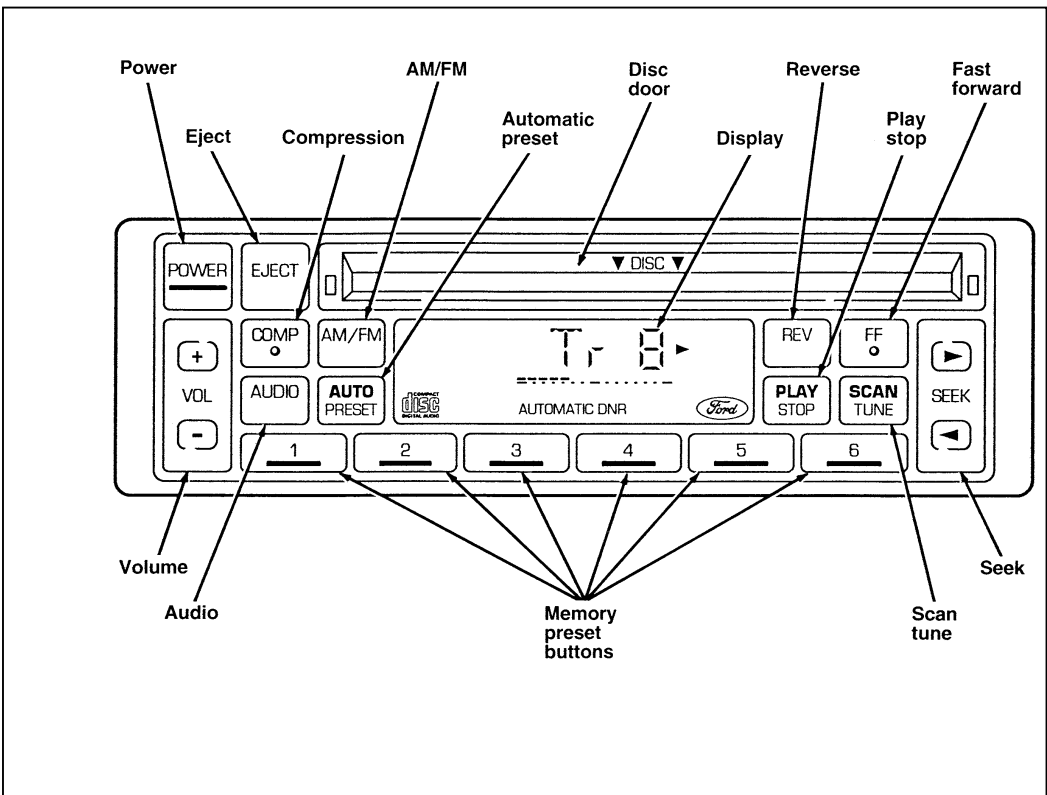

Compact Disc Radio

Compact Disc Radio

The Compact Disc Radio combines the Electronic Stereo Radio with the Ford Compact Disc Player.

Using the Controls on Your New Radio/CD Player

Most of the features of this unit work for both radio and CD operation. Also, some of the knobs and buttons control several different functions, so be sure to read all of the operating instructions carefully.

How to turn the radio on and off

Press the “POWER” button to turn the radio on. Press it again to turn it off.

How to adjust the volume

Press the (+/-) side of the “VOL” button to increase/decrease the volume. Bars illuminate in the display to show the relative volume level.

NOTE: If the volume level is set above a certain listening level when the ignition switch is turned off, when the ignition switch is turned back on, the volume will come back to a “nominal” listening level. However, if the radio power is turned off (with the “POWER” button), the volume will remain in the position it was set at when radio power is switched back on.

Selecting the AM or FM frequency band

Push the “AM/FM” button to select the desired frequency band. When in the radio mode, pushing the button more than once will alternate between AM, FM1 and FM2. These functions are used with the station memory buttons described under *How to tune radio stations*.

Electronic Sound Systems

How to tune radio stations

There are four ways for you to tune in a particular station. You can manually locate the station using the “SCAN/TUNE” button, “SEEK” the station, “SCAN” to the station or select the station by using the memory buttons, which you can set to any desired frequency. These four methods are described below.

■ Using the “SCAN/TUNE” button to manually tune

You can change the frequency up or down one increment at a time (FM changes in increments of 200kHz; AM changes in increments of 10kHz) by first pressing the “SCAN/TUNE” button twice (display shows “TUNE”), then — **within approximately five seconds** — pressing and releasing either the top ► or bottom ◀ half of the “SEEK” button. To change frequencies quickly, press and **hold down** either the top or bottom half of the “SEEK” button. While you are manually tuning, the display will show a blinking “M”.

Manual tuning adjusts your radio to any allowable broadcast frequency, whether or not a station is present on that frequency. (See *All About Radio Frequencies* in this section.)

■ Using the “SEEK” function

This feature on your radio allows you to automatically select listenable stations up or down the frequency band. Press the top ► half of the “SEEK” button to select the next listenable station up the frequency band. Press the bottom ◀ half of the button to select the next listenable station down the frequency band. By pressing and holding the button, listenable stations can be passed over to reach the desired station.

■ Using the “SCAN/TUNE” button to scan radio stations

Pressing the “SCAN/TUNE” button once enters the scan mode (display will indicate “SCN”). Pushing the top ► half of the “SEEK” button will begin the scan mode up the frequency band, stopping on each listenable station for approximately five seconds. Pushing the bottom ◀ half of the “SEEK” button will begin the scan mode down the frequency band, again stopping on each listenable station for approximately five seconds.

To stop the scan mode on the presently sampled station press the “SCAN/TUNE” button again.

■ Setting the Station Memory Preset buttons

Your radio is equipped with 6 station memory buttons. These buttons can be used to select up to 6 preset AM stations and 12 FM stations (6 in FM1 and 6 in FM2).

1. Select a band, then select a frequency.
2. Press one of the memory buttons and hold the button until the sound returns. That station is now held in memory on that button.
3. Follow the two steps above for each station memory preset button you want to set.

NOTE: If the vehicle’s battery is disconnected, the clock and station memory preset buttons (if programmed in auto mode) will need to be reset.

■ Using the Automatic Memory Store feature

With Auto Memory Store, you can continually set strong stations into your memory buttons without losing your existing memory presets, which is especially handy while traveling. Your radio will automatically set your memory buttons to the strong local stations so you don’t have to continually manually tune to existing stations.

Electronic Sound Systems

Activate Auto Memory Store by pushing the “AUTO PRESET” button once. Your radio will set the first five strong stations of the band you are in (AM, FM1 or FM2) into the memory buttons. The display will show “AUTO”, then run through the frequencies, stopping momentarily on the stations being set into the memory buttons. The radio is now in the “AUTO” mode and this display will show “AUTO” each time a preset is activated.

NOTE: If there are fewer than five strong stations in the frequency band, the remaining unfilled buttons will store the last strong station detected on the band.

After all stations have been filled, the radio will begin playing the station stored on memory button 1.

To deactivate the Auto Memory Store mode and return to the manually-set memory button stations (or those stations set using Auto Memory Load), simply push the “AUTO PRESET” button. Display will show “AUTO” then “OFF”.

The next time Auto Memory Store is activated on that band, the radio will store the next set of five strong stations.

Adjusting the tone balance and speaker output of your radio

■ Increasing or decreasing bass response

Push the “AUDIO” button repeatedly until the display reads “BASS”. Push the top (+) of the “VOLUME” button to increase bass (more “lows”), and push the button (–) to decrease bass (less “lows”).

■ Increasing or decreasing treble response

Push the “AUDIO” button repeatedly until the display reads “TREB”. Push the top (+) of the “VOLUME” button to increase treble (more “highs”), and push the bottom (–) to decrease treble (less “highs”).

■ Adjusting speaker balance

Balance control allows you to adjust the sound distribution between the right and left speakers. Push the “AUDIO” button repeatedly until the display button reads “BAL”. Push the top (+) of the “VOLUME” button to shift the sound to the right speakers, and push the bottom (–) to shift the sound to the left speakers.

■ Adjusting speaker fader

Fade control allows you to adjust the sound distribution between the front and rear speakers. Push the “AUDIO” button repeatedly until the display reads “FADE”. Push the top (+) of the “VOLUME” button to shift the sound to the front speakers, and push the bottom (–) to shift the sound to the rear speakers.

NOTE: Illuminated bars in the display show relative levels of bass and treble, and positions of speaker balance and fader functions (left to right, front to rear).

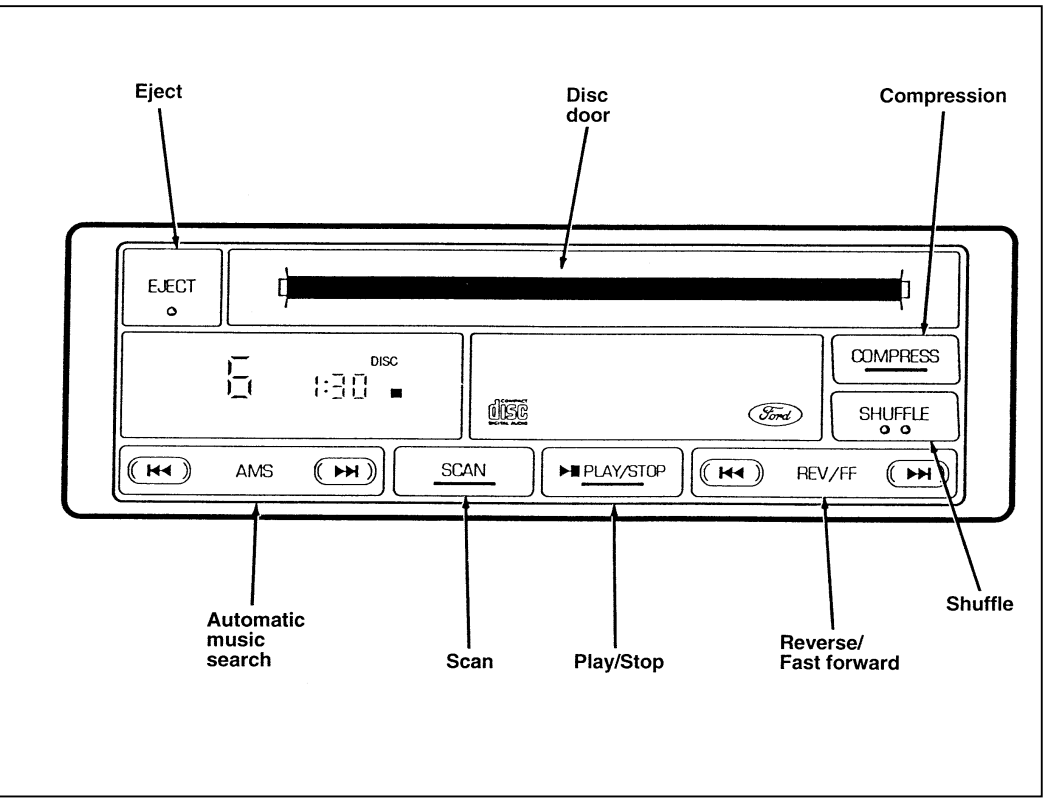

Ford Compact Disc Player

Ford Compact Disc Player

The Ford Compact Disc Player operates when the Audio System is on and a disc is inserted (**label side up**). Handle the disc by its edge only. (Be sure to read and follow all of the care and cleaning instructions under *How To Take Care of and Clean Your CD Player and Discs* in this section.)

The digital display on your CD player shows the track (selection) number and the elapsed time. Indicators for play ►, stop ■, compression on (“COMP”) and shuffle on (“SHUF”) are also in the display. (These features are described later.)

Once a disc is inserted, operation of the CD player will override that of the radio.

NOTE: The volume, bass, treble, balance and fader controls on the radio are also used with the CD player. Refer to earlier operating instructions on these controls.

How to insert a disc and begin play

Insert one disc, **label side up** into the disc opening. When inserted, the disc automatically loads into the unit and play starts at the beginning of the first track (selection).

When the disc reaches the end, the disc player automatically returns to the beginning of the disc and resumes playing.

NOTE: Once a disc is inserted, the disc opening is secured to prevent the accidental insertion of a second disc.

NOTE: The CD player has heat protection circuitry to protect the laser diode. If the temperature of the player reaches 167°F (75°C), the heat detection circuit will shut off the player and “TOO HOT” will scroll in the display for approximately five seconds (radio will resume playing). When the temperature returns to normal operating range, the CD player will again be operational.

Electronic Sound Systems

How to stop and restart the CD player

When a disc is loaded, the unit automatically enters the play mode and the play indicator ► illuminates. To stop temporarily, press the “PLAY/STOP” button or the “AM/FM” button. The stop indicator ■ in the display illuminates and operation returns to the radio mode. To resume CD play, press the “PLAY/STOP” button once again.

NOTE: If the ignition key is turned OFF during play and then is set to the ON or ACCESSORY position, the CD player will resume playing in the mode it was in when ignition was turned off.

How to locate a selection on your CD player using Automatic Music Search (AMS)

An “AMS” (Automatic Music Search) control on your CD player allows you to quickly find a particular selection on the disc. Press the left ◀◀ side of the “AMS” control to locate a previous selection or the right ▶▶ side of the “AMS” control to locate a later selection.

How to fast forward or reverse your CD player

To quickly search for a particular point in a selection, press the right ▶▶ button (to fast forward) or the left ◀◀ button (to reverse). While either button is pressed, the disc goes forward or backward at two different speeds depending on how long the button is held down. (Pressing either button for more than approximately three seconds will speed up the process.) Release the button at the desired point (found by watching the elapsed playing time in the display or listening to the sound during fast forward or reverse).

When you have reached the end of the disc by keeping the fast forward ▶▶ side of the button pressed, the display will show the end time of the last track and the sound will be muted. When the fast forward ▶▶ side of the button is released, the player resumes play at the beginning of the first track.

A “1” and “0:00” will appear in the display when the beginning of the disc is reached by pressing the rewind  side of the button.

Using the “SCAN” function

Press the “SCAN” button to enter the scan mode. The CD player will begin scanning the disc, stopping on each listenable track for approximately eight seconds. This continues until you press the “SCAN” button a second time or eject the disc. While in the scan mode, the display flashes “SCAN.”

Special features of your CD player

■ Compression

The compression feature will bring soft and loud passages closer together for a more consistent listening level.

To turn the compression on, press the “COMPRESS” button. When on, the compression indicator (“COMP”) will appear in the display. Press the button again to turn off.

■ Shuffle

The shuffle feature on your CD player allows you to listen to your disc selections in a different order. When this feature is activated, your CD player will randomly select and play tracks on the disc.

Press the “SHUFFLE” button to turn on, press it again to turn off. When on, the shuffle indicator (“SHUF”) will appear in the display. When the player is between selections, the display will show a moving dash (“-”) around the perimeter of the display.

Electronic Sound Systems

■ Shuffle and Scan

Both the shuffle and scan features can be activated simultaneously. In this mode, the player will randomly pick a selection and play the first eight seconds. This process is continued until either the “SCAN” button or “SHUFFLE” button is pressed a second time.

■ Automatic Disc Storage

If the disc is ejected from the CD player but is not removed from the disc opening within approximately 10 seconds, the player will automatically reload the disc for storage, unless the disc is automatically ejected due to a “focus error” (disc inserted upside down). In this case, the disc will not be automatically reloaded.

How to eject the disc

Push the “EJECT” button in the upper left corner of your CD player to stop play, eject the disc and resume radio or tape operation of your audio system.

How To Take Care of and Clean Your CD Player and Discs

To ensure the continued performance of your Ford Compact Disc Player, carefully read the following precautions:

- Always handle the disc by its edge. Never touch the playing surface.
- Before playing, inspect the disc for any contamination. If needed, clean the disc with an approved disc cleaner, such as the Discwasher® Compact Disc Cleaner or the Allsop 3® Compact Disc Cleaner, by wiping from the center out to the edges. **Do not use a circular motion to clean.**
- Do not clean discs with solvents such as benzine, thinner, commercially available cleaners or antistatic spray intended for analog records.

-
- Do not expose the disc to direct sunlight or heat sources such as defroster and floor heating ducts. Do not leave any discs in a parked car in direct sunlight where there may be a considerable rise in temperature or damage may result.
 - After playing, store the disc in its case.
 - If a disc has already been inserted, do not try to insert another disc. Doing so may damage the disc player.
 - Do not insert anything other than a disc into the disc player.

CAUTION: The use of optical instruments with this product will increase eye hazard as the laser beam used in this compact disc player is harmful to the eyes. Do not attempt to disassemble the case. Refer servicing to qualified personnel only.

Common Operating Conditions of Your CD Player

The following information is designed to help you recognize typical situations that could be mistakenly interpreted as mechanical malfunctions of the disc player.

- A disc is already loaded.
- The disc is inserted with the label surface downward.
- The disc is dusty or defective.
- The player's internal temperature is above 167°F (75°C). Allow the player to cool off before operating.
- Different manufacturers of compact discs may produce discs with different dimensions or tolerances, some of which may not be within industry standards or in accordance with the CD format. Because of this, a new disc that is free of dust and scratches could be defective and may not play on your Ford Compact Disc Player.

Electronic Sound Systems

If play does not begin after the CD button is pushed:

- The radio is not on.
- The unit is in the stop mode.
- Moisture may have condensed on the lenses within the unit. If this occurs, remove the disc and wait approximately an hour until the moisture evaporates.

If the sound skips:

- Badly scratched discs or extremely rough roads will cause the sound to skip. Skipping will not damage the disc player or scratch the discs.

Electronic Stereo Radio

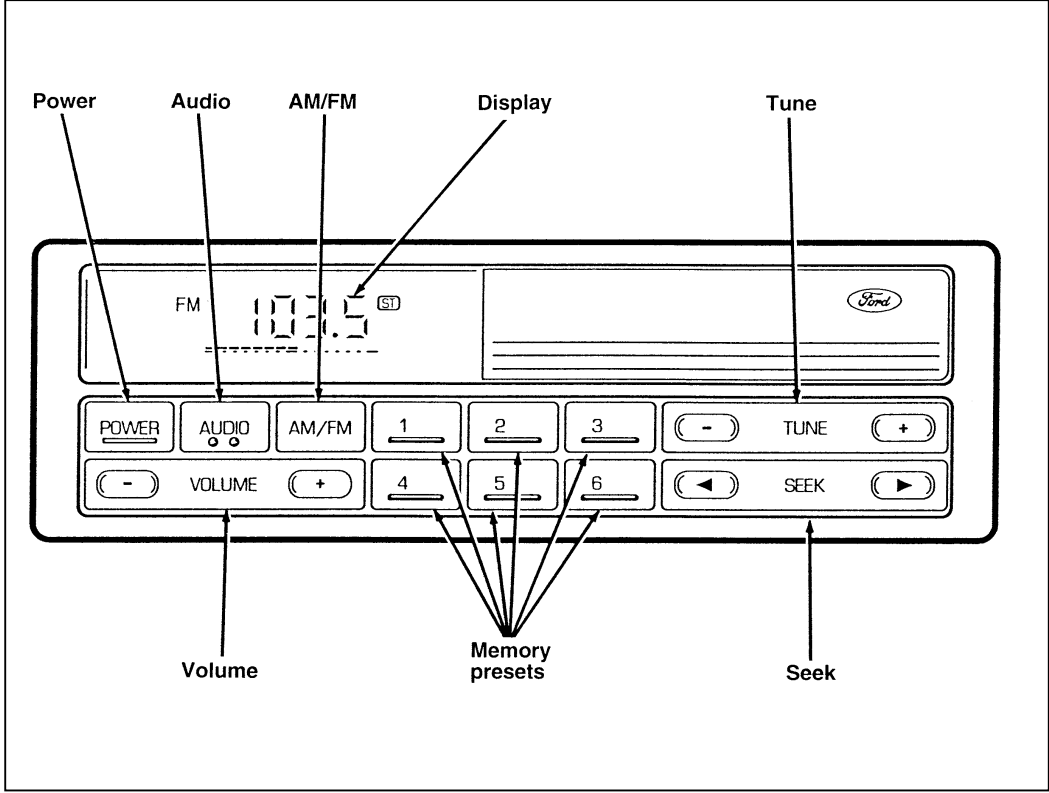

Electronic Sound Systems

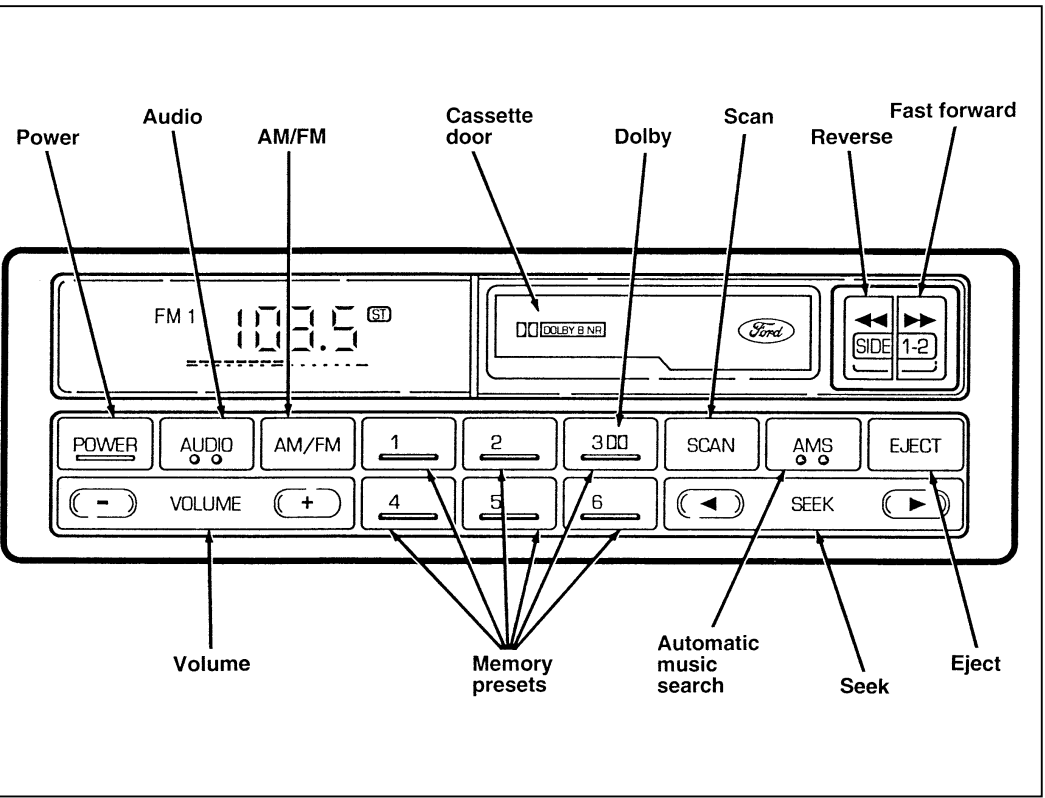

Electronic Stereo Radio with Cassette

Electronic Stereo and Stereo Cassette Radios

Both the Electronic Stereo Radio and Cassette Radio offer full electronic tuning with new soft touch controls.

Using the Controls on Your New Radio

How to turn the radio on and adjust the volume

Press the “POWER” button to turn the radio on. Press it again to turn it off.

Press the right (+) side of the “VOLUME” button to increase the volume. Press the left (-) side of the button to decrease the volume. Illuminated bars in the display show the relative volume level.

NOTE: If the volume level is set above a certain listening level when the ignition switch is turned off, when the ignition switch is turned back on, the volume will come back to a “nominal” listening level. However, if the radio power is turned off (with the “POWER” button), the volume will remain in the position it was set at when radio power is switched back on.

Selecting the AM or FM frequency band

Push the “AM/FM” button to select the desired frequency band. Pushing the button more than once will alternate between AM, FM1 and FM2. These functions are used with the station memory buttons described under *How to tune radio stations*.

Electronic Sound Systems

How to tune radio stations (Stereo Radio)

■ Using the “TUNE” function

You can change the frequency up or down one increment at a time by pressing and releasing either the right (+) or left (-) side of the “TUNE” button. To change frequencies quickly, press and hold down either the right or left side of the “TUNE” button.

Manual tuning adjusts your radio to any allowable broadcast frequency, whether or not a station is present on that frequency. (See *All About Radio Frequencies* in this section.)

■ Using the “SEEK” function

This feature on your radio allows you to automatically select listenable stations up or down the frequency band. Press the right ► side of the “SEEK” button to select the next listenable station up the frequency band. Press the left ◀ side of the button to select the next listenable station down the frequency band. By holding the button down, listenable stations can be passed over to reach the desired station.

How to tune radio stations (Stereo Cassette Radio)

■ Using the “AMS” function to manually tune your radio (Stereo Cassette Radio)

You can change the frequency up or down one increment at a time by first pressing the “AMS” button (display shows “TUNE”) then within approximately five seconds pressing and releasing either the right ► or left ◀ side of the “SEEK” button. To change frequencies quickly, press and **hold down** either the right or left side of the “SEEK” button.

Manual tuning adjusts your radio to any allowable broadcast frequency, whether or not a station is present on that frequency. (See *All About Radio Frequencies* in this section.)

■ Using the “SEEK” function

This feature on your radio allows you to automatically select listenable stations up or down the frequency band. Press the right ► side of the “SEEK” button to select the next listenable station up the frequency band. Press the left ◀ side of the button to select the next listenable station down the frequency band. By holding the button down, listenable stations can be passed over to reach the desired station.

■ Using the “SCAN” function (Stereo Cassette Radio)

Press the “SCAN” button to enter the scan mode. The radio will begin scanning up the frequency band, stopping on each listenable station for approximately a five-second sampling. This continues until you press the “SCAN” button a second time. The display flashes “AM” or “FM.”

■ Setting the Station Memory Preset buttons

Your radio is equipped with 6 station memory buttons. These buttons can be used to select up to 6 preset AM stations and 12 FM stations (6 in FM1 and 6 in FM2).

Follow the easy steps below to set these buttons to the desired frequencies:

1. Select a band, then select a frequency.
2. Press one of the memory buttons and hold the button until the sound returns. That station is now held in memory on that button.
3. Follow the two steps above for each station memory preset button you want to set.

NOTE: If the vehicle’s battery is disconnected, the clock and station memory preset buttons (if programmed in auto mode) will need to be reset.

Electronic Sound Systems

Adjusting the tone balance and speaker output of your radio

■ Increasing or decreasing bass response

Push the “AUDIO” button repeatedly until the display reads “BASS.” Push the right (+) side of the “VOLUME” button to increase bass (more “lows”), and push the left (-) side to decrease bass (less “lows”).

■ Increasing or decreasing treble response

Push the “AUDIO” button repeatedly until the display reads “TREB.” Push the right (+) side of the “VOLUME” button to increase the treble (more “highs”), and push the left (-) side to decrease treble (less “highs”).

■ Adjusting speaker balance

Balance control allows you to adjust the sound distribution between the right and left speakers. Push the “AUDIO” button repeatedly until the display reads “BAL.” Push the right (+) side of the “VOLUME” button to shift the sound to the right speakers, and push the left (-) side to shift the sound to the left speakers.

■ Adjusting speaker fader

Fade control allows you to adjust the sound distribution between the front and rear speakers. Push the “AUDIO” button repeatedly until the display reads “FADE.” Push the right (+) side of the “VOLUME” button to shift the sound to the front speakers, and push the left (-) side to shift the sound to the rear speakers.

NOTE: Illuminated bars in the display show relative levels of bass and treble, and positions of speaker balance and fader functions (left to right, front to rear).

Using the Controls of Your Cassette Tape Player

NOTE: Radio power must be on to use the cassette tape player.

How to insert a tape

Insert a cassette (with the open edge to the right) firmly into the tape door opening, making sure the cassette is completely in and “seated.”

How to locate a desired track on the tape

NOTE: The tape track number indicated in the display does not necessarily correspond to the tape track or side number on the cassette label. It is used only to indicate when the tape mechanism reverses tracks.

■ Using the Automatic Music Search (“AMS”)

Press and hold the “AMS” button (“AMS” will appear in the display). Then, push the left ◀◀ button to rewind to the beginning of the current selection or press the right ▶▶ button to fast forward to the beginning of the next selection.

■ Fast forwarding the tape

Push the right ▶▶ button to fast forward the tape.

■ Rewinding the tape

Push the left ◀◀ button to rewind the tape.

■ How to change the side of the tape being played

The alternate track (other side) of the tape can be selected at any time by pushing both fast-wind buttons ◀◀ and ▶▶ at the same time.

How to eject the tape

To stop the tape and eject the cassette, press the “EJECT” button. The radio will resume playing.

Electronic Sound Systems

Using the Dolby® B noise reduction feature

NOTE: Noise reduction system manufactured under license from Dolby Labs Licensing Corporation. “Dolby” and double-D symbol are trademarks of Dolby Laboratories Licensing Corporation.

Push station memory button 3 to activate Dolby® B Noise Reduction.

Tips on Caring for the Cassette Player and Tapes

In order to keep your cassette tape player performing the way it was meant to, read and follow these simple precautions:

- Using a Ford Cassette Cleaning Cartridge to clean the tape player head after 10-12 hours of play will help maintain the best playback sound and proper tape operation.
- Only cassettes that are 90 minutes long or less should be used. Tapes longer than 90 minutes are thinner and subject to breakage or may jam the tape player mechanism.
- Protect cassettes from exposure to direct sunlight, high humidity and extreme heat or cold. If they are exposed to extreme conditions, allow them to reach a moderate temperature before playing.
- If a tape is loose inside the cassette, tighten it before playing by putting your finger or a pencil into one of the holes and turning the hub until the tape is tight.
- Loose labels on cassette tapes can become lodged in the mechanism. Remove any loose label material before inserting a cassette.
- Do not leave a tape in the cassette tape player when not in use. High heat in the vehicle can cause the cassette to warp.

Common Radio Reception Conditions

Several conditions prevent FM reception from being completely clear and noise-free, such as the following:

1. Distance/Strength

The strength of the FM signal is directly related to the distance the signal must travel. The listenable range of an average FM signal is approximately 25 miles (40 kilometers). Beyond this distance, the radio is operating in a fringe area and the signal becomes weaker.

2. Terrain

The terrain (hilly, mountainous, tall buildings) of the area over which the signal travels may prevent the FM signal from being noise-free.

3. Rounded off frequencies

Some FM radio stations advertise a “rounded-off” frequency which is not the frequency they actually broadcast on. For example, a radio station that is assigned a frequency of 98.7 MHz may call itself “Radio 99” even though 99.0 MHz is not an allowable FM broadcast frequency.

Electronic Sound Systems

Important Warranty and Service Information

■ Warranty

Your sound system is warranted for three years or 36,000 miles (60,000 kilometers), whichever comes first. Consult your vehicle warranty booklet for further information. Ask your dealer for a copy of this limited warranty.

■ Service

At Ford Electronics, we stand behind our audio systems with a comprehensive service and repair program. If anything should go wrong with your Ford audio system, return to your dealer for service. There is a nationwide network of qualified Ford authorized repair centers to assist you.

Driving Your Contour

Procedures for driving your vehicle will vary depending on which type of *transaxle* your vehicle has. You may be familiar with the term “transmission.” We use *transaxle* because it is a more accurate term for vehicles that have front-wheel drive.

Your vehicle will have one of the following types of transaxles:

- an automatic overdrive transaxle with transaxle control switch, or
- a manual transaxle.

If you are not sure which transaxle your vehicle has, talk to your dealer.

Your vehicle is equipped with an Electronic Powertrain Control Module that limits engine and/or vehicle speeds with a cut-out mode to promote durability.

Driving with an Automatic Overdrive Transaxle

Your automatic overdrive transaxle provides fully automatic operation in either D (Overdrive) or with the transaxle control switch depressed. Driving with the shift selector in D (Overdrive) gives the best fuel economy for normal driving conditions. For manual control, start in 1 (First) and then shift manually.

Putting Your Vehicle in Gear

You must push in the thumb button to move the gearshift to the position you choose.

⚠ WARNING

Hold the brake pedal down while you move the gearshift lever from position to position. If you do not hold the brake pedal down, your vehicle may move unexpectedly and injure someone.
--

To operate:

1. Start the engine.
2. Depress and hold the brake pedal.
3. Move the gearshift lever out of P (Park).

Your vehicle is equipped with a Brake Shift Interlock safety feature. This feature prevents the gearshift from being moved from the P (Park) position until the brake pedal is depressed. This feature is active when the ignition is in the ON position. If the gearshift lever CANNOT be moved from P (Park) with the brake pedal depressed:

1. Turn the engine off and remove the ignition key.
2. With the parking brake applied and the brake pedal depressed, insert a screwdriver about 2" (5 cm) into the square opening to the right of the gearshift at the base of the console.
3. Rotate the screwdriver point rearward.
4. Push and hold the thumb button and move the gearshift.
5. Remove the screwdriver when the gearshift moves from the P (Park) position.

Driving Your Contour

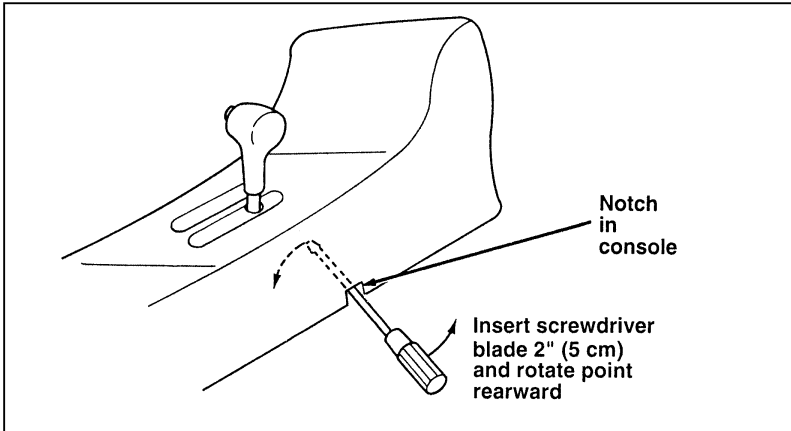

Overriding the brake shift interlock

The console-mounted gearshift will lock when you turn the key to the LOCK position. When the gearshift is in any position except P (Park), the ignition key cannot be turned to LOCK or removed from the steering column. TO REMOVE THE KEY, the gearshift lever **must** be in P (Park).

Once the gearshift is secure in the desired position, release the brake pedal and use the accelerator as necessary.

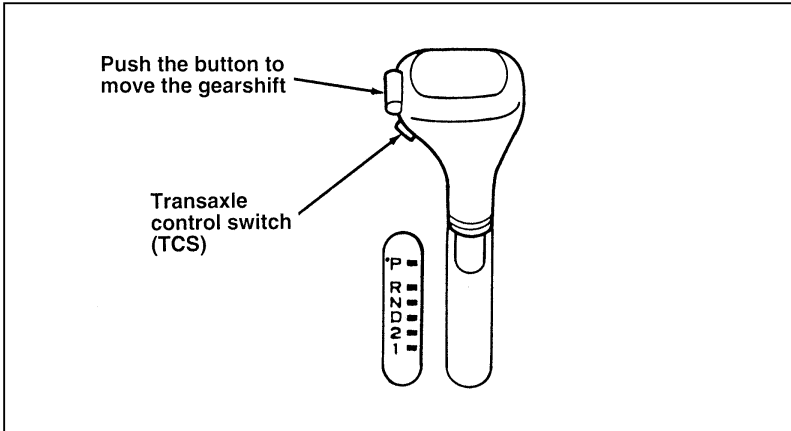

Console-mounted automatic transaxle shift control lever

R (Reverse)

With the gearshift in the R (Reverse) position, the vehicle will move backward. You should always come to a complete stop before shifting into or out of R (Reverse).

N (Neutral)

In N (Neutral), the wheels of the transaxle are not locked. Your vehicle will roll freely, even on the slightest incline, unless the parking brake or brakes are on.

Driving

Your vehicle's gearshift is console-mounted on the floor. The Transaxle Control Switch (TCS) is located on the gearshift handle. The transaxle control indicator light (OD OFF) is located on the instrument panel. You can put the gearshift lever in any of the several positions.

The OD OFF light is off (not illuminated) during normal vehicle operation. This allows the transaxle to upshift and downshift from first through fourth gears. When the TCS is pressed, the

Driving Your Contour

transaxle control indicator light will illuminate (OD OFF) on the instrument panel. When this OD OFF is illuminated the transaxle will upshift and downshift from first through third gears and provide coast braking in second and third gears.

To return the transaxle to normal operation (first through fourth gears) depress the TCS again. This switch may be used to cancel overdrive any time the vehicle is being driven. Each time your vehicle is started, the overdrive system will automatically be in the normal overdrive mode and the light will not be illuminated.

When to use D (Overdrive — without Transaxle Control Switch activated)

D (Overdrive) is the usual driving position for an automatic overdrive transaxle. It automatically upshifts or downshifts as the vehicle speeds or slows.

However, D (Overdrive) also shifts into a fourth gear — an overdrive gear — when your vehicle cruises at a consistent speed for any length of time. This fourth gear will increase your fuel economy when you travel at cruising speeds.

When to use D (Drive — with Transaxle Control Switch activated)

D (Overdrive) may not be appropriate for certain terrain. If the transaxle shifts back and forth between third and fourth gears while you are driving on hilly roads or if your vehicle requires additional power for climbing hills, depress the TCS. D (Drive) also gives more engine braking to slow your vehicle on downgrades than D (Overdrive).

When to use 2 (Second)

When your vehicle is in 2 (Second), it automatically starts off in second gear. Use 2 (Second) to help drive up moderately steep hills or restart from a standstill on slippery roads. It prevents the transaxle from frequently shifting up and down. It also gives more engine braking than D (Drive) (with Transaxle Control Switch activated) when going down hills.

Do not go faster than 55 mph (90 km/h) in this gear. You can upshift from 2 (Second) into D (Overdrive) at any speed.

When to use 1 (First)

This position limits the transaxle to first gear. It helps brake the vehicle when going down hills where 2 (Second) is not sufficient.

Do not go faster than 38 mph (60 km/h) in this gear. You can upshift from 1 (First) to 2 (Second) or from 1 (First) to D (Overdrive) at any speed.

P (Park)

Always come to a complete stop before you shift into P (Park). Make sure that the gearshift is securely latched in P (Park). This locks the transaxle and prevents the front wheels from rotating.

 WARNING
--

Always set the parking brake fully and make sure that the gearshift is securely latched in P (Park).

 WARNING
--

Never leave your vehicle unattended while it is running.

You can tell the gearshift is securely latched when the push button has popped out. In this position the gear shift selector lever cannot be moved unless the button is pushed in.

Driving Your Contour

Driving with a Manual Transaxle

Using the Clutch

In order to start the vehicle, the clutch pedal must be fully depressed to the floor. Before starting the engine, make sure the vehicle is in Neutral and the parking brake is set.

After the engine starts, allow it to idle for a few seconds. Then, hold your right foot on the brake pedal and release the parking brake. With the clutch pedal depressed to the floor with your left foot, move the gearshift into 1 (First) or R (Reverse).

To move the vehicle, take your right foot off the brake pedal and then slowly release the clutch pedal. (You may need to press down slowly on the accelerator at the same time that you release the clutch pedal.)

Do not drive with your foot resting on the clutch pedal and do not use the clutch to hold your vehicle at a standstill while waiting on a hill. These actions will seriously reduce clutch life.

Idling the Vehicle

When the vehicle is stopped and the engine is running, DO NOT rest your hand on or apply any pressure to gearshift lever when the clutch pedal is not depressed. This may result in erratic engine operation.

Shifting the Gears

The gearshift for a manual transaxle is mounted on the floor. The gearshift can be in one of seven possible positions, as shown.

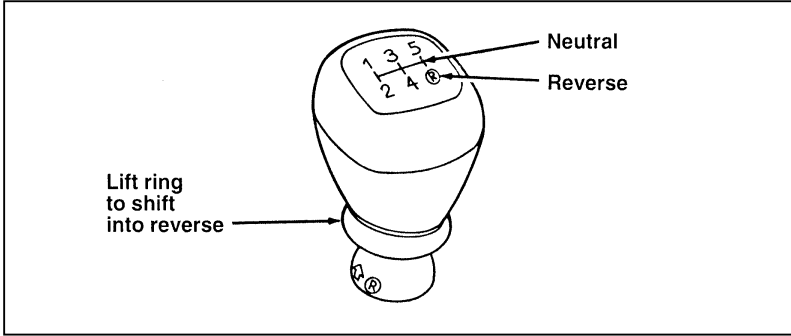

The positions of the floor-mounted gearshift

Always push the clutch pedal all the way to the floor when you shift. You should upshift according to the speeds given in the shift speed chart.

Backing up

To shift into R (Reverse):

1. Completely stop your vehicle.
2. Depress the clutch pedal to the floor and place the gearshift lever in the Neutral position. Do not release the clutch pedal.

NOTE: If the following step is not followed, a grinding noise may occur.

3. Wait a minimum of three seconds before attempting to shift into R (Reverse) gear.
4. Push the gearshift lever completely to the right, pull up the ring on the stalk of the gearshift lever, and then pull rearward on the gearshift lever to engage the R (Reverse) gear.
5. If the R (Reverse) gear is engaged, slowly release the clutch pedal from the floor.

Driving Your Contour

Upshifting

Most of the time, you should upshift at the following speeds:

2.0L Engine 5-Speed Transaxle Shift Speed Schedules				
Recommended Upshifts:	During Acceleration		During Cruise*	
	Nominal Shift Speed		Nominal Shift Speed	
Shift from	mph	km/h	mph	km/h
First to Second	14	22	12	19
Second to Third	25	40	20	32
Third to Fourth	33	53	29	46
Fourth to Fifth	48	77	40	64

*The vehicle can be shifted at lower speeds to improve fuel economy.

2.5L Engine 5-Speed Transaxle Shift Speed Schedules				
Recommended Upshifts:	During Acceleration		During Cruise*	
	Nominal Shift Speed		Nominal Shift Speed	
Shift from	mph	km/h	mph	km/h
First to Second	14	22	10	16
Second to Third	25	40	20	32
Third to Fourth	33	53	31	50
Fourth to Fifth	45	73	40	64

*The vehicle can be shifted at lower speeds to improve fuel economy.

Downshifting

When you slow down or climb a steep hill, always downshift before the engine starts to lose power. Downshifting reduces the chance of stalling and gives your vehicle better acceleration to increase speed again.

When you drive down steep hills, downshifting helps you keep a safe speed and helps prevent unnecessary wear on the brakes.

When you come to a stop, do not downshift through each gear. Disengage the clutch and use the brake as necessary.

Downshifting through the gears decreases your vehicle's fuel economy.

Do not attempt to shift into 1 (First) gear with the clutch pedal depressed at speeds higher than 20 mph (30 km/h). If you do, it could cause a complete clutch failure, making your vehicle inoperative.

Traction Control (If equipped)

The traction control system prevents the wheels from spinning on slippery roads.

Working with the anti-lock brake system, the traction control system monitors the speed of the wheels as they roll over the road surface. When a wheel starts to spin because of slippery conditions, the traction control system slows the engine by closing the throttle. At speeds below 35 mph (55 km/h) the traction control system also applies the brake to the spinning wheel.

When the traction control system becomes active, the driver may notice a very slight kick and then a hard resistance in the accelerator pedal, and a mechanical noise. The traction control system light on the instrument panel comes on or flashes on and off during activation.

Driving Your Contour

The traction control system can be turned off manually by pushing the T/C OFF button on the instrument panel to the left of the steering wheel. The traction control system light will remain on as a reminder that the system is turned off.

Each time the vehicle is started, the traction control system will automatically be on. When the ignition is turned to the ON position, the traction control system light comes on for approximately three (3) seconds.

If the light does not come on when the ignition is turned to the ON position or if it does not come on when the T/C OFF button is pressed, have the system serviced by your dealer or a qualified service technician as soon as possible to restore the benefits of the traction control feature. You do not need to have the vehicle towed in.

Steering Your Vehicle

Your vehicle comes with power steering. Power steering uses energy from the engine to help steer your vehicle.

If the amount of effort needed to steer your vehicle changes at a constant vehicle speed, have the power steering system checked. If the power steering system breaks down (or if the engine is turned off), you can steer the vehicle manually but it takes more effort.

Never hold the steering wheel to the extreme right or left for more than five seconds if the engine is running. This can damage the power steering pump.

Brakes

Applying the Brakes

Your vehicle may have four-wheel power anti-lock disc brakes or power front disc and rear drum anti-lock brakes which adjust automatically through everyday use.

If your vehicle does not have anti-lock brakes, it may have four-wheel power disc brakes or power front disc brakes and rear drum brakes, which adjust automatically as the brake pads or linings wear down.

If your vehicle does not have anti-lock brakes, apply the brake pedal gradually. Use the “squeeze” technique — push on the brake pedal with a steadily increasing force. This allows the wheels to continue to roll while you are slowing down, which lets you steer properly.

If your vehicle does not have anti-lock brakes, extreme braking can make the wheels lock and slide, causing you to lose control of the steering. If the wheels lock, release the brake pedal and repeat the “squeeze” technique.

Do not drive with your foot resting on the brake pedal; you will wear out the linings and increase your vehicle’s stopping distance. Brake rotor damage may also eventually occur.

NOTE: If you are driving down a long or steep hill, shift to a lower gear and do not apply your brakes continuously. If you apply your brakes continuously, they may overheat and become less effective.

Occasional brake squeal during light to moderate stops does not affect the function of the brake system and is normal. However, if the squeal becomes louder or more frequent, have your brakes inspected by your dealer or a qualified service technician.

Anti-lock Brake System (If equipped)

Your vehicle may come with the optional anti-lock brake system. Whenever your wheels start to lock (which could result in a skid) the anti-lock brake system prevents the lock-up by automatically releasing and re-applying the brakes. The brake pedal will pulsate as a result of the automatic releasing and re-applying of the brakes. In spite of this improvement in braking performance, you should continue to be cautious in all

Driving Your Contour

hazardous driving situations, especially when driving on hazardous road surfaces. Even with your anti-lock brake system, you may not have total control of your vehicle when braking on roads with loose surfaces such as snow or gravel, holes in the pavement, or alternating patches of slippery and dry surfaces.

If the brake pedal is applied while the vehicle is driven over uneven road surfaces, the ABS may cycle and the driver may sense a pulsation in the brake pedal, accompanied by a slight up and down movement of the pedal height and a clicking sound. This may also happen when driving on an inclined surface such as a driveway while making a sharp turn. This is a normal condition.

Your vehicle may have an Anti-lock Brake System feature. If it does, check the Anti-lock Brake System light each time you start the engine. If it stays on longer than three (3) seconds, shut off the engine and restart. If it stays on, that means the Anti-lock Brake feature is not working and should be serviced immediately to restore the benefits of the Anti-lock feature. Normal braking is not affected unless the brake warning light is also lit.

The Anti-lock Brake System has self-check capabilities. As described above, the system turns on the anti-lock light each time you start your engine. After the engine is started and the anti-lock light turns off, the system performs another test the first time the vehicle reaches 5 mph (8 km/h) (12 mph [20 km/h] for vehicles equipped with the traction control system). The system turns on the ABS pump motor for approximately 1/2 second. At this time, a mechanical noise may be heard and felt. This is a normal part of the self-check feature. If a malfunction is found during this check the anti-lock light will come on.

Ford Motor Company has not found any negative effects of mobile radio transmitting equipment installed on vehicles with the ABS system providing that the radio is installed according

to the radio manufacturer's instructions. However, if you have had a mobile radio transmitter installed and the check ABS light comes on (at any time other than immediately after turning the key to the ON position) have your mobile radio dealer inspect the radio installation. Also, if the ABS system is activated other than during maximum braking, have your mobile radio installation checked.

Parking Brake

The parking brake should be used whenever you park your vehicle.

The parking brake lever is located between the front seats. To set the parking brake, put your foot on the brake pedal while pulling the parking brake handle fully and firmly upward.

To release the parking brake, put your foot on the brake pedal, pull the handle upward and push the button. Then lower the handle to the released position while holding the button in.

⚠ WARNING

Always set the parking brake fully and make sure that the gearshift is securely latched in P (Park) (automatic transaxle) or in 1 (First) (manual transaxle).
--

⚠ WARNING

To prevent personal injury, do not release the parking brake while outside the vehicle.
--

⚠ WARNING

If the parking brake is fully released, but the Brake System light remains on, have the brakes checked immediately. They may not be working properly.
--

Driving Your Contour

The parking brake is not designed to stop a moving vehicle, but you can use the parking brake to stop your vehicle in an emergency if the normal brakes fail. However, since the parking brake applies only the rear brakes, the stopping distance will increase greatly and the handling of your vehicle will be adversely affected.

Always check the Brake Warning Light each time you start your engine. Driving with the parking brake on will cause the brakes to wear out quickly and will reduce the fuel economy.

Driving Under Special Conditions

Tips for Safe Driving

As with any new vehicle, yours may drive and handle differently from your previous vehicle. Use care until you become accustomed to its various features and driving characteristics.

Operate your vehicle within reasonable limits. Sudden acceleration, deceleration, turning, or combinations of these maneuvers can cause a vehicle to behave differently than anticipated.

Driving in Bad Weather

Slippery roads

On some slippery road surfaces, front-wheel drive may provide better acceleration than rear-wheel drive. However, this does not mean that your vehicle can stop any faster or any better than a vehicle with rear-wheel drive. Exercise the same caution while driving on slippery roads with your front-wheel drive vehicle as you would with a rear-wheel drive vehicle.

- Do not quickly move the steering wheel unless necessary.
- Drive slower than you normally would.
- Give your vehicle more distance to stop.

-
- Pump the brake pedal steadily and evenly to avoid locking your wheels.
 - Consider using one of the lower gears.

⚠ WARNING

To avoid losing control on slippery roads, do not downshift into 1 (First) with the automatic transaxle when moving faster than 20 mph (32 km/h). Do not downshift into 1 (First) with the manual transaxle when moving faster than 10 mph (16 km/h).

⚠ WARNING

If your vehicle has speed control, do not use it on slippery roads. You could lose control of your vehicle and could injure someone.

If you have an automatic transaxle and your vehicle gets stuck (for example, in mud or snow), you may try to “rock” it out of the spot. Shift, in a steady rhythm, between forward and reverse gears. While in each gear, press lightly on the accelerator and release.

⚠ WARNING

Do not spin the wheels at over 35 mph (55 km/h). The tires may fail and injure a passenger or bystander.

By moving the vehicle backward and forward, you may gain enough momentum to move out of the spot. Do not rock the vehicle for more than a few minutes. This may overheat the engine, damage the transaxle, or damage the tires. If you are still stuck after a minute or two of rocking, call for a tow truck.

Driving Your Contour

High water

Do not drive through flooded areas unless you are sure that the water is below the bottom of the wheel rims.

If you must drive through high water, drive slowly. You may have limited traction or wet brakes, so allow extra stopping distance because your vehicle will not stop as quickly as usual.

After you drive through the standing water, apply your brakes gently several times as your vehicle moves slowly. This helps to dry the brakes.

Driving With a Heavy Load

There are limits to the amount of weight your vehicle can carry or tow. The total weight of your vehicle, plus the weight of the passengers and cargo, should never be more than the Gross Vehicle Weight Rating (GVWR). Also, the weight that your vehicle carries over the front axle and rear axle should never be more than the Gross Axle Weight Rating (GAWR) for the respective axle.

You can find your vehicle's GVWR and GAWR on the Safety Compliance Certification Label on the left front door lock facing or on the door latch post pillar.

The weight limits of your vehicle's tires affect the GVWR or GAWR limitations. Usage of replacement tires with higher weight limit than originals does not increase GVWR or GAWR. Usage of lower capacity replacement tires may lower GVWR and GAWR limitations.

 WARNING
If the GVWR or the GAWR specified on the Safety Compliance Certification Label is exceeded, your vehicle may be damaged or you may lose control and injure someone.

Limiting Your Vehicle's Load

The load that you add to your vehicle must not exceed the maximum load stated on the Safety Compliance Certification Label attached to the left front door pillar or the left front door lock facing.

To figure the weight of your vehicle's load, add the weights of:

- the driver and passengers
- luggage and any other items that you put in your vehicle
- the tongue load of the loaded trailer
- the weight of any equipment that has been added to your vehicle since it was delivered to your dealer

If you do not know the actual weights of these items, use the following procedure to figure the weight of a load:

1. Weigh your vehicle without the driver, passengers and luggage. You might take your vehicle to a shipping company or an inspection station for trucks.
2. Then weigh your vehicle with the driver, passengers and luggage.
3. Subtract the first reading from the second to figure the total weight of the load.

After determining this load, you must also make sure that the total weight of your vehicle, plus the load it carries, is less than its GVWR. Also, make sure that the weight your vehicle carries over each axle is less than the GAWR for the respective axle.

You can find the GVWR and GAWR on the Safety Compliance Certification Label on the left front door lock facing or the door latch post pillar.

Driving Your Contour

If your vehicle exceeds the GVWR, remove cargo from your vehicle accordingly. If your vehicle exceeds the GAWR for either axle, shift the load or remove cargo accordingly.

 WARNING
--

<p>Improper distribution of your vehicle's load or carrying weight in excess of the amount shown on the tire decal can cause rapid tire wear or loss of vehicle control.</p>

Trailer Towing

Your vehicle is capable of towing a trailer of up to a maximum of 1,000 lbs. (454 kg) gross trailer weight with a maximum tongue load of 100 lbs (45 kg). It should also have 25 sq. ft. (2.3 sq. meters) or less frontal area. Do not drive faster than 55 mph (90 km/h) while towing a 1,000 lb. (454 kg) trailer.

Your vehicle does not come from the factory fully equipped to tow. No towing packages are available through Ford or Lincoln/Mercury dealers.

Because towing a trailer puts extra strain on your vehicle, you must follow certain precautions for your safety and the good of your vehicle:

- Stay within the load limits when you tow. (See *Knowing Your Vehicle's Load Limits*.)
- Carefully and thoroughly prepare your vehicle for towing, making sure to use the right equipment and to attach it properly. (See *Preparing to Tow* in this chapter.)
- Use extra caution when driving your vehicle while you tow. (See *Driving while you tow* in this chapter.)
- Service your vehicle more frequently if you tow a trailer. (See *Servicing your vehicle if you tow* in this chapter.)

Ten to 15% of the loaded trailer's weight should be on the tongue. However, the tongue load should never exceed 10% of the maximum weight that your vehicle can safely tow.

New vehicles should be driven 2,000 miles (3,200 km) before towing a trailer.

⚠ WARNING

Towing trailers beyond the maximum recommended gross trailer weight exceeds the limits of the vehicle and could result in engine damage, transaxle/axle damage, structural damage, loss of control, and personal injury.

⚠ WARNING

Do not tow a trailer when the temporary spare tire is being used.

You should also limit your trailer's load when you tow in high altitudes.

Preparing to Tow

For your safety and for the good of your vehicle, use the right equipment for the type of trailer you tow. Also, make sure that all towing equipment is properly attached to your vehicle. If you are not certain that you are using the right equipment in the proper manner, see your Ford or Lincoln-Mercury dealer.

Do not use hitches that clamp onto your vehicle's bumper. The bumper is not designed to bear the load.

Driving Your Contour

Using the hitch

Your vehicle uses a load carrying hitch. Because this type of hitch places the tongue load of a trailer on the rear wheels of your vehicle, you must distribute the load in your trailer so that 10 to 15% of the total weight of the trailer is on the tongue.

Tie down the load so that it does not shift and change the weight on the hitch. This will prevent damage to your vehicle and make your vehicle easier to handle.

Connecting the safety chains

Always attach the trailer's safety chains to your vehicle. They help protect your trailer if the hitch breaks.

To connect the trailer's safety chains:

1. Cross the chains under the trailer tongue and attach them to your vehicle's frame or hook retainers. Never attach the safety chains to your vehicle's bumper. The bumper is not designed to bear the weight of a trailer.
2. Make sure that you leave enough slack in the chains to allow you to turn corners.

If you use a rental trailer, follow the instructions that the rental agency gives you.

Connecting the trailer's brakes

Electric brakes and manual, automatic, or surge-type hydraulic brakes are safe if you install them properly and adjust them according to the manufacturer's instructions. Be sure that your trailer's brakes meet local and federal regulations.

 WARNING
--

<p>Do not connect a trailer's hydraulic brake system directly to your vehicle's brake system. Your vehicle may not have enough braking power and your chances of having a collision greatly increase.</p>
--

Connecting the trailer's lights

Do not connect a trailer's lighting system wiring directly to your vehicle's lighting system wiring. To get the proper equipment for hooking up your trailer's lights, see your local trailer dealer and your Ford dealer. Be sure to follow their instructions carefully.

If you do not install trailer lights correctly, you may cause damage to the vehicle's lighting system.

Driving While You Tow

Be especially careful when driving while you tow a trailer. Never drive faster than 45 mph (70 km/h) when you tow in hilly country on hot days. Also, anticipate stops so that you can brake gradually.

If your vehicle has a manual transaxle and you are towing a trailer, you should select gear positions which will avoid jerking or excessive engine speed. If you need to drive excessively in 1 (First) or 2 (Second), it may indicate that the trailer is too big or heavily loaded for your vehicle's drivetrain. Continuous driving in these two gears while towing a trailer is not recommended.

Driving Your Contour

When you tow up or down steep hills, move the manual transaxle gearshift to a lower gear. This will increase engine power on upgrades and engine braking on downgrades.

When you tow in steep hills, move the automatic transaxle to 1 (First) when descending. This will give more engine braking on downgrades. The automatic transaxle will automatically downshift to the proper gear on upgrades.

If you use the speed control while you are towing on very long, steep grades, the speed control may shut off.

Servicing Your Vehicle If You Tow

If you tow a trailer for a long distance, your vehicle will need to be serviced more frequently than usual. Refer to the *Maintenance Schedule and Record* booklet for additional information.

Roadside Emergencies

Jump-Starting Your Vehicle

Your vehicle's battery may die if you leave the lights on or any electrical equipment on after you turn the engine off. If this happens, you may be able to jump-start from a booster battery to start your vehicle.

⚠️ WARNING

The gases around the battery can explode if exposed to flames, sparks, or lit cigarettes. An explosion could result in injury or vehicle damage.

⚠️ WARNING

To protect yourself when charging a battery, always shield your face and eyes. Make sure that you can breathe fresh air.

⚠️ WARNING

Applying too much pressure on the ends when lifting a battery could cause acid to spill. Lift the battery with a carrier or with your hands on the opposite corners.

⚠️ WARNING

Batteries contain sulfuric acid which burns skin, eyes, and clothing.

If the acid touches someone's skin, eyes, or clothing, immediately flush the area with water for at least 15 minutes. If someone swallows the acid, have him or her drink lots of milk or water first, then Milk of Magnesia, a beaten egg, or vegetable oil. Call a doctor immediately.

To avoid damaging your vehicle or your battery, and to avoid injury to yourself, follow these directions for preparing your vehicle to jump-start and connecting the jumper cables in the order they are given. If in doubt, call for road service.

Preparing Your Vehicle

1. Your vehicle has a 12-volt starting system, so you need to use a 12-volt jumper system. You will damage your starting motor, ignition system, and other electrical parts if you connect them to a 24-volt power supply (either two 12-volt batteries in series or a 24-volt generator set).
2. Do not disconnect the battery of the disabled vehicle. You could damage the vehicle's electrical system.
3. Park the booster vehicle close to the hood of the disabled vehicle. **Make sure the vehicles do not touch each other.** Set the parking brake on both vehicles and stay clear of the engine cooling fan and other moving parts.
4. Check all battery terminals and remove any excessive corrosion before you attach the jumper cables.
5. Turn on the heater fan in both vehicles. Press the DEFROST button. Turn off all other switches and gauges.

Connecting the jumper cables

1. Connect one end of the first jumper cable to the positive (+) terminal of the discharged battery. (You can connect either jumper cable to the positive (+) terminal, as long as you use the same cable for both positive terminals.) Most jumper cables have a red cable and a black cable. The red cable is generally used for the positive terminals and the black for the negative ones.
2. Connect the other end of the first cable to the positive (+) terminal of the booster battery.

Roadside Emergencies

3. Connect one end of the second cable to the negative (-) terminal of the booster battery — NOT to the discharged battery.
4. Connect the other end of the second cable to a good metallic surface on the engine or frame of the disabled vehicle.

<p> WARNING</p>

<p>Do not connect the end of the second cable to the negative (-) terminal of the battery to be jumped. A spark may cause an explosion of the gases that surround the battery.</p>

Make sure vehicles do not touch
Make connections in numerical
order (disconnect in reverse
order 4, 3, 2, 1)

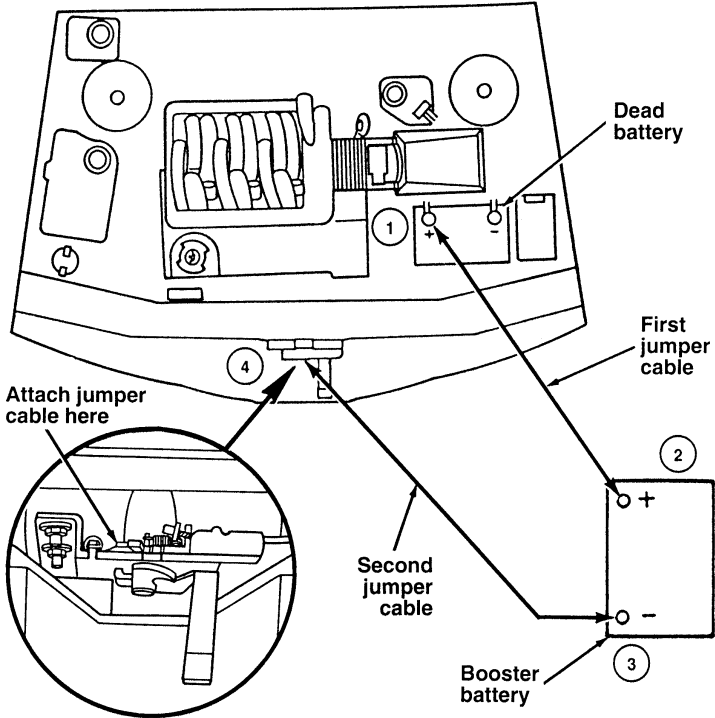

Sequence for connecting jumper cables

Roadside Emergencies

Jump-Starting

1. Make sure that the jumper cables are not in the way of moving engine parts, then start the booster vehicle. Run the engine at a moderate speed.
2. Let the discharged battery charge for a few minutes and then start the disabled vehicle. It may take a couple of tries before the vehicle starts. If the vehicle does not start after several attempts, there may be a different problem.
3. When both vehicles are running, let them idle for a few minutes to charge the discharged battery.

Removing jumper cables

1. **Always remove the jumper cables in the reverse order.** Remove the negative (-) end of the jumper cable from the metallic surface on the engine or frame of the disabled vehicle.
2. Remove the negative (-) cable from the booster battery.
3. Remove the positive (+) cable from the booster battery.
4. Remove the other end of the positive (+) cable from the discharged battery.

After the vehicle is started, let it idle for a while to let the engine “relearn” its idle conditions. Drive it around for a while with all electrical accessories turned off to let the battery recharge. **You may need to use a battery charger to fully recharge the battery.**

If you need to replace your battery, see *Battery* in the *Servicing Your Vehicle* chapter.

Changing a Tire

If you get a flat tire while you are driving, do not apply the brake heavily. Instead, gradually decrease the speed. Hold the steering wheel firmly and slowly move to a safe place on the side of the road. Park on a level spot, turn off the ignition, set the parking brake, and turn on the hazard flashers.

The Temporary Spare Tire

You may have a high pressure temporary spare tire. This spare tire is smaller than a regular tire and is designed for emergency use only. Use it only when you get a flat tire and replace it as soon as you can. This spare tire is marked with the words “TEMPORARY USE ONLY” so that you can easily identify it.

 WARNING
--

<p>If you use the temporary spare tire continuously or do not follow these precautions, the tire could fail, causing you to lose control of the vehicle, possibly injuring yourself or others.</p>

When you drive with the temporary spare tire, DO NOT:

- exceed 50 mph (80 km/h) under any circumstances.
- load your vehicle so that it is heavier than the maximum vehicle load rating listed on the tire decal.
- tow a trailer.
- use tire chains on this tire.
- try to repair the temporary spare tire or remove it from its wheel.
- use the wheel for any other type of vehicle.

Roadside Emergencies

- drive through an automatic car wash with this tire. Because the temporary spare tire is smaller than a conventional tire, it reduces the ground clearance. Your vehicle may get caught in the rails and it could be damaged.

Spare Tire Location

The spare tire is stored under the carpet on the floor of the trunk.

You will find additional instructions for the spare tire on the wheel decal (located on the temporary spare wheel).

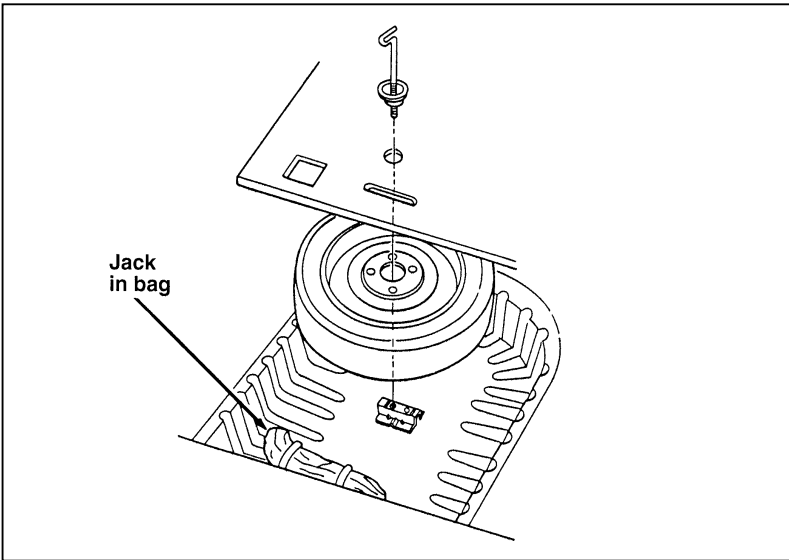

The temporary spare tire

Preparing to Change the Tire

1. Make sure that your vehicle will not move or roll. If you have an automatic transaxle, put the gearshift in P (Park). If you have a manual transaxle, put the gearshift in 1 (First). Set the parking brake and block the wheel that is diagonally opposite the tire that you are changing.

When one of the front wheels is off the ground, the transaxle alone will not prevent the vehicle from moving or slipping off the jack, even if the vehicle is in P (automatic) or 1 (manual). To prevent the vehicle from moving when you change one of the front tires, put a block behind the wheel that is diagonally opposite to the tire.

⚠ WARNING

If the vehicle slips off the jack, you or someone else could be seriously injured.

2. Get out the spare tire and jack.

⚠ WARNING

To avoid injury, never run the engine with one wheel off the ground, such as when changing a tire.

3. Remove the wheel cover from the wheel with the tapered end of the wheel lug wrench. Insert and twist the handle, then pry against the inner wheel cover flange. For information about removing optional wheel center ornaments see *Styled Polycast Wheel Ornaments* later in this section.
4. Loosen the wheel lug nuts by pulling up on the handle of the wrench one-half turn counterclockwise. Do not remove the wheel lug nuts until you raise the tire off the ground. For information about removing anti-theft lug nuts, see *Anti-Theft Wheel Lug Nuts* later in this section.

Roadside Emergencies

Removing and Replacing the Tire

1. Place the scissors-type jack under the side of the vehicle and adjust the jack height with the jack handle. The jack should fit in the notch in the vertical rocker panel flange which is nearest to the wheel to be changed. The front and rear jacking notches on each side of the vehicle are marked by arrows in the rocker panel.

On sport models with “skirts,” you must remove a portion of the skirt before placing the jack under the vehicle. Squeeze the removeable portion of the skirt and pull down. A tether connects it to the rocker panel.

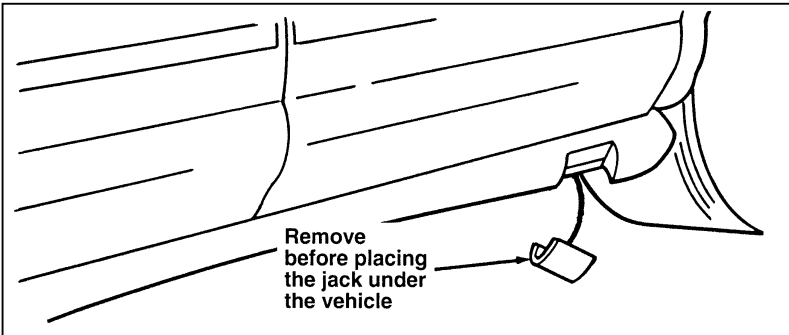

Sports models with skirts

⚠ WARNING

To lessen the risk of personal injury, do not put any part of your body under the vehicle while changing a tire. Do not start the engine when your vehicle is on the jack. The jack is only meant for changing the tire.

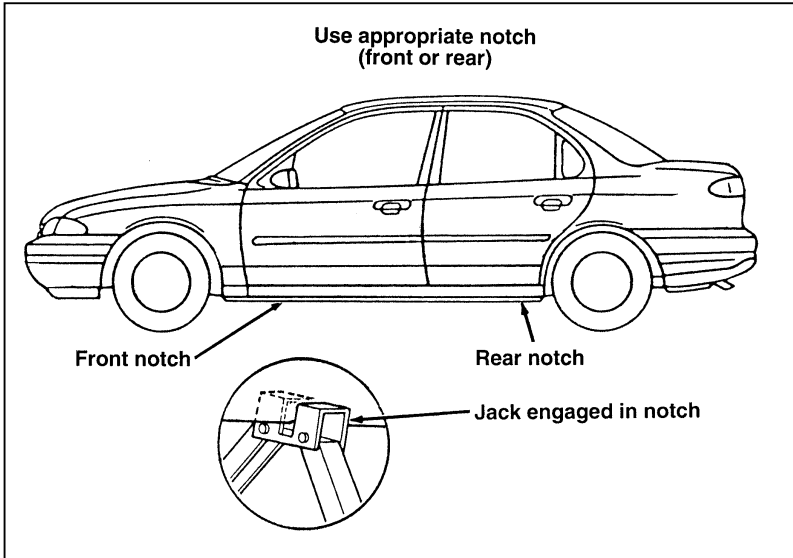

The notches for the jack

2. Turn the jack handle clockwise until the wheel clears the ground. Remove the wheel lug nuts.
3. Replace the flat tire with the spare tire, making sure that the air valve stem is facing outward.
4. Reinstall the lug nuts, tightening until the wheel is snug against the hub. The beveled edges on the lug nuts face inward. Do not fully tighten the lug nuts until you lower the vehicle. If you do, you could force the vehicle off the jack.
5. Lower the vehicle by turning the jack handle counterclockwise.

Roadside Emergencies

- Remove the jack and fully tighten the lug nuts in the order shown in the following illustration. As soon as possible, have your dealer or a qualified service technician check the lug nuts for proper torque specifications.

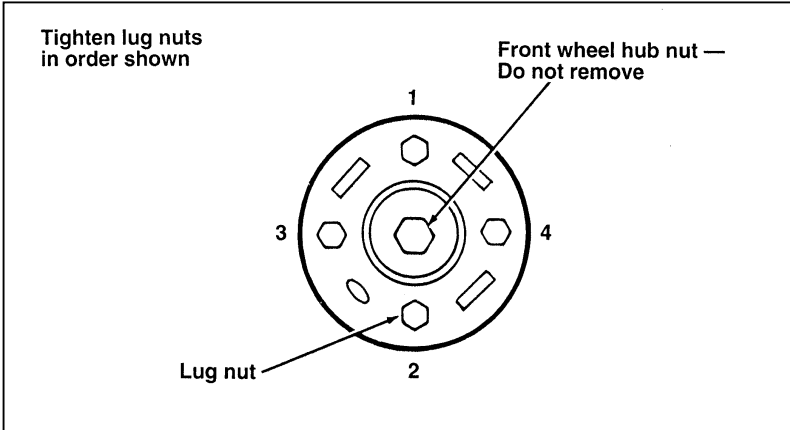

The lug nuts on the wheel

- Place any wheel covers and ornaments in the trunk.
- Put the tire, jack, and wrench away. Make sure the jack is securely fastened so it does not rattle when you drive.
- Unblock the wheels.

Removing and Replacing Styled Polycast Wheel Ornaments

To remove a wheel ornament, insert the tapered end of the jack handle between the ornament and wheel and pry the ornament from the wheel.

To install the polycast wheel center ornament, you should insert one side of the ornament into the center of the wheel opening and strike the opposite side with the palm of your hand until the ornament is seated in the opening.

Anti-Theft Wheel Lug Nuts (If equipped)

If your vehicle has this option, one of the lug nuts on each wheel locks and must be unlocked with a special key. If you lose the key, send the registration card to the manufacturer (not to the dealer) to get a replacement key.

NOTE: If you lose your lug wrench/lug nut key assembly, see your nearest Ford or Lincoln/Mercury dealer who has access to a master set of keys.

DO NOT USE A POWER IMPACT WRENCH ON THE LUG NUT KEY.

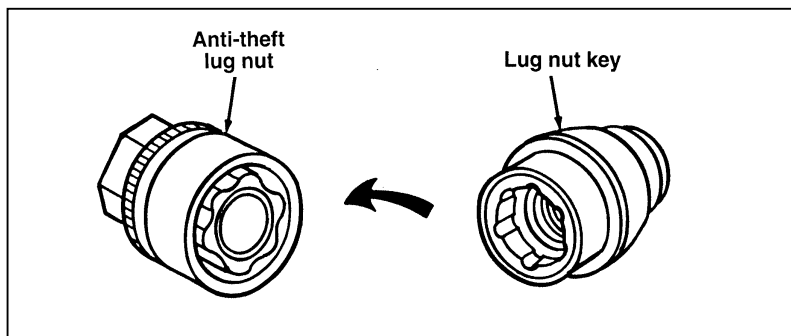

The anti-theft lug nut and key

Removing the anti-theft lug nut

Insert the key over the locking lug nut. Make sure that you hold the key square to the lug nut. If you hold the key on an angle, you may damage the key and the lug nut.

Place the lug nut wrench over the lug nut key and apply pressure on the key with the wrench. Turn the wrench in a counterclockwise direction to remove the lug nut.

Roadside Emergencies

Replacing the anti-theft lug nut

Insert the key over the locking lug nut. Place the lug nut wrench over the lug nut key and, while applying pressure on the key, install the lug nut.

If the Engine Cranks But Does Not Start or Does Not Start After a Collision

The Fuel Pump Shut-off Switch

If the engine cranks but does not start or if you have had a collision, the fuel pump shut-off switch may have been triggered. The shut-off switch is a device that stops the fuel pump when your vehicle has been involved in a substantial jolt.

For information on how to check and reset the fuel pump shut-off switch, see *Fuel pump shut-off switch* in the Index.

Towing Your Vehicle

If you need to have your vehicle towed, contact a professional towing service or, if you are a member, your roadside assistance center. Recommended towing options include wheel lift towing or flat bed towing.

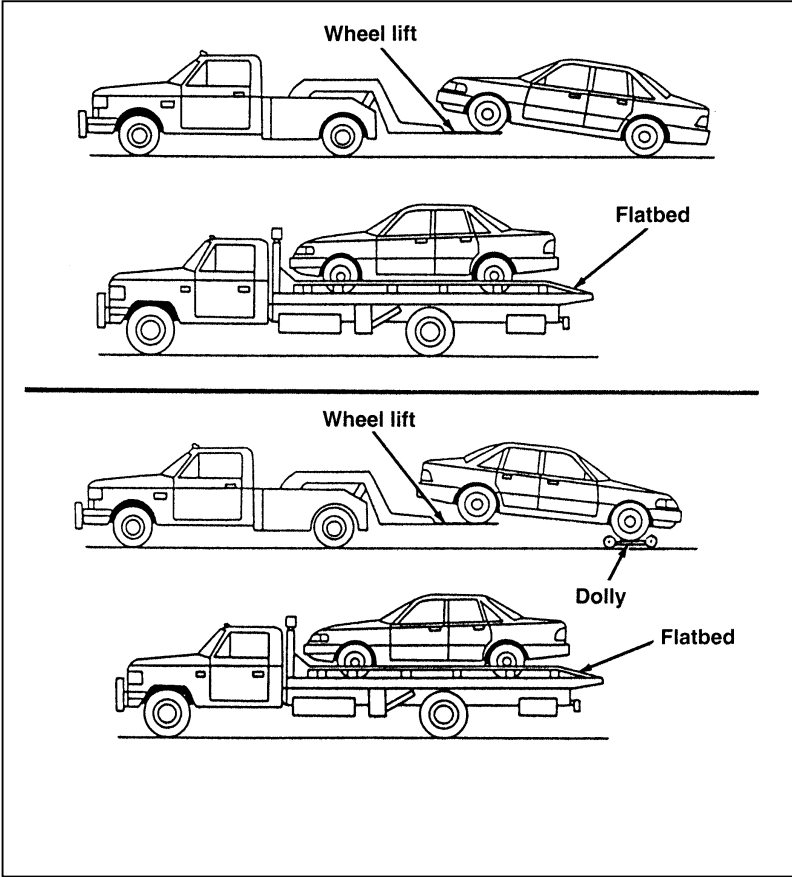

When calling for a tow truck, tell the operator what kind of vehicle you have. A towing manual is available from Ford Motor Company for all authorized tow truck operators. Have your tow truck driver refer to this manual for the proper hook-up and towing procedures for your vehicle.

Roadside Emergencies

Towing Your Vehicle Behind Another Vehicle

At times, you may want to tow your vehicle behind another vehicle, such as a recreational vehicle, a car, or a truck.

Before you have your vehicle towed:

- Release the parking brake.
- Move the gearshift to N (Neutral).
- Turn the ignition to the OFF position.
- Unlock the steering wheel.

Do not tow your vehicle at a speed faster than 35 mph (55 km/h) or for a distance greater than 50 miles (80 km) unless the drive wheels are placed on dollies.

Do not tow your vehicle at a speed faster than 55 mph (90 km/h) if you have a manual transaxle. Your maximum towing distance is unlimited.

 WARNING
Never use a tow bar that attaches to the bumper when you tow your vehicle. This could damage the bumper and cause an accident.

Customer Assistance

Roadside Assistance

Ford Motor Company has set up a 24-hour, seven-day-a-week hotline with trained operators that put you in touch with the help you need if you experience a problem with your vehicle. This complimentary service is provided to you throughout your warranty period of 3 years or 36,000 miles (3 years or 60,000 km), whichever comes first. To purchase Roadside Assistance coverages beyond this period, through Ford Auto Club, contact your Ford or Lincoln-Mercury dealer (not available in Canada).

Roadside Assistance will cover the following:

- Mount your spare if you have a flat tire.
- Jump-start your battery if it is dead.
- Unlock your vehicle if you are locked out.
- Bring you fuel if you run out.
- Tow your vehicle if you are stranded. Even non-warranty related tows, like accidents or getting stuck in mud or snow, are covered (some exclusions apply, such as impound towing and repossession).

How to use Roadside Assistance

Your Roadside Assistance identification card can be found in the Owner Guide portfolio in your glove compartment. Complete the card and place it in your wallet for quick reference.

To receive roadside assistance in the United States call 1-800-241-FORD (in Canada call 1-800-665-2006).

Should you need to arrange for roadside assistance yourself, Ford Motor Company will reimburse the reasonable cost. To obtain information about reimbursement call 1-800-241-FORD (in Canada call 1-800-665-2006).

If You Have a Service Problem

Ford Motor Company has authorized Ford and Lincoln-Mercury dealerships that can service your vehicle for you. This chapter tells you how to get service or maintenance for your vehicle.

Service/Maintenance Concerns (U.S. or Canada)

Ford recommends taking your vehicle to your selling dealer who wants to ensure your continued satisfaction. You may, however, take your vehicle to any authorized Ford or Lincoln-Mercury dealer. In most cases, your dealer will be able to resolve your concern.

If you are not satisfied with the service you received from your dealership's service department, talk to the service manager at the dealership, or if you still are not satisfied, talk to the owner or general manager of the dealership. In most cases, you will have your concern resolved at this level.

If you are away from home when your vehicle needs to be serviced, or if you need more help than the dealer gave you, contact the Ford Customer Assistance Center to find an authorized dealership that may be able to help you.

<p style="text-align: center;">Ford Motor Company Customer Assistance Center 300 Renaissance Center P.O. Box 43360 Detroit, Michigan 48243 1-800-392-3673 (FORD) TDD for the hearing impaired: 1-800-232-5952</p>
--

If you live in Canada and have any questions or concerns that the dealership cannot answer, contact the Customer Assistance Centre.

Customer Assistance

Customer Assistance Centre
Ford Motor Company of Canada, Limited
P.O. Box 2000
Oakville, Ontario L6J 5E4
1-800-565-3673 (FORD)

Please have the following information available when contacting Ford Customer Assistance:

- your telephone number (both business and home)
- the name of the dealer and the city where the dealership is located
- the year and make of your vehicle
- the date purchased
- the current mileage on your vehicle
- your Vehicle Identification Number (VIN) listed on your owner card and/or your vehicle ownership license

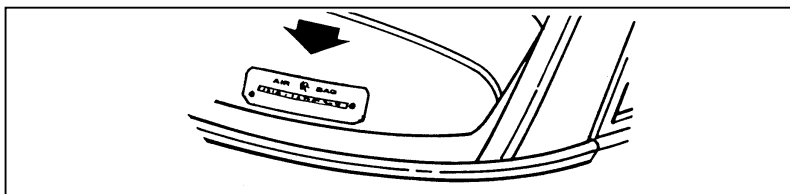

Vehicle Identification Number (VIN/Serial Number)

If you still have a service or product complaint, you may wish to contact the Dispute Settlement Board (U.S. only) or the Canadian Motor Vehicle Arbitration Plan (CAMVAP) in Canada.

The Dispute Settlement Board (U.S. Only)

The Dispute Settlement Board is a voluntary, independent dispute-settlement program available free to owners or lessees of qualifying Ford Motor Company vehicles.

The Dispute Settlement Board may not be available in all states. Ford Motor Company reserves the right to change eligibility limitations, modify procedures and/or to discontinue this process at any time without notice and without incurring obligations.

What Kind of Cases Does the Board Review?

The Board reviews all product performance and service complaints on Ford, Mercury and Lincoln Cars and Ford and Mercury Light Trucks under warranty that have not been resolved by a dealer or Ford Motor Company.

The Board does not review issues involving:

- A non-Ford product
- A non-Ford dealership
- A vehicle sales transaction
- A request for reimbursement of consequential expenses unless incidental to a service or product complaint being reviewed
- Items not covered by your warranty
- Alleged liability claims
- Property damage where such damage is significant when compared to the economic loss alleged under the warranty dispute
- Cases currently in litigation

Customer Assistance

- Vehicles not used primarily for personal, family, or household purposes

NOTE: Complaints involving vehicles on which applicable express written new vehicle warranties have expired at receipt of your application are not eligible. Eligibility may differ according to state law. For example, see the unique brochure for California purchasers/lessees.

How Does the Board Work?

The Board has four members:

- three consumer representatives
- a Ford or Lincoln-Mercury dealer

Consumer candidates for Board membership are recruited and trained by an independent consulting firm. Dealers are chosen because of their business leadership qualities.

If the involved vehicle is within 36 months and 36,000 miles of the date of delivery (warranty start date), you have a right to make an oral presentation before the Board by indicating your choice on the application. Also, oral presentations may be requested by the Board. A decision is made by the Board by simple majority vote.

Board members review all the materials related to each complaint and, based on the available information, arrive at a fair and impartial decision. Decisions are based on the written statements and any oral presentations made by each of the involved parties.

Because the Board usually meets only once a month, some cases will take longer than 30 days to be reviewed. The Board will make every effort to resolve each case within 40 days after it receives the customer application form.

After your case has been reviewed, the Board will mail you its decision in writing. It will also provide you with a form to indicate your acceptance or rejection of an award decision. The decisions of the Board are binding on the dealer and Ford, but customers may have other options available to them under state or federal law.

The decisions of the Board, however, may be introduced into evidence by any party in subsequent legal proceedings that may be initiated.

How Do You Contact the Board?

Write to the Board at the following address to request a brochure/application. You will be sent a brochure and a one-page customer application form. The form should be completed and mailed to the same address.

Dispute Settlement Board
P.O. Box 5120
Southfield, MI 48086-5120

What is the Review Process?

Your application will be reviewed and if it is determined to be eligible, you will receive an acknowledgment indicating the file number assigned to your application and the local Board address. At the same time, your dealer and Ford Motor Company representative are asked to submit statements.

To review your case properly, the Board needs the following information:

- legible copies of all documents and maintenance or repair orders that relate to the case

Customer Assistance

- the year, make, model, and vehicle identification number
- the date you bought your vehicle
- the date of repair and the mileage at the time of repair
- the current mileage
- the name of the dealer who sold you the vehicle or who serviced your vehicle
- a brief description of your unresolved complaint
- a brief summary of actions that were taken with the dealer and Ford Motor Company
- the names (if known) of all people you contacted at the dealership
- a description of the action you want done to resolve your concern.

Should your application NOT qualify for review, an explanation will be mailed to you.

Reporting Safety Defects (U.S. Only)

If you believe that your vehicle has a defect which could cause a crash or could cause injury or death, you should immediately inform the National Highway Traffic Safety Administration (NHTSA) in addition to notifying Ford Motor Company.

If NHTSA receives similar complaints, it may open an investigation, and if it finds that a safety defect exists in a group of vehicles, it may order a recall and remedy campaign. However, NHTSA cannot become involved in individual problems between you, your dealer, or Ford Motor Company.

To contact NHTSA, you may either call the Auto Safety Hotline toll-free at 1-800-424-9393 (or 366-0123 in the Washington, D.C. area) or write to: NHTSA, U.S. Department of Transportation, 400 Seventh Street, Washington D.C. 20590. You can also obtain other information about motor vehicle safety from the Hotline.

Ford of Canada Customer Assistance

If you live in Canada and have any questions or concerns that the dealership cannot answer, contact the Customer Assistance Centre.

**Customer Assistance Centre
Ford Motor Company of Canada, Limited
P.O. Box 2000
Oakville, Ontario L6J 5E4
1-800-565-3673 (FORD)**

Please have the following information available when contacting the Customer Assistance Centre:

- your telephone number (both business and home)
- the name of the dealer and the city where the dealership is located
- the year and make of your vehicle
- the date purchased
- the current mileage on your vehicle
- your Vehicle Identification Number (VIN) listed on your owner card and/or your vehicle ownership license

Customer Assistance

Canadian Motor Vehicle Arbitration Plan (CAMVAP)

If a specific item of concern arises, where a solution cannot be reached between a vehicle owner, Ford of Canada, and/or one of its dealers (that all parties can agree upon), the owner may wish to use the services offered by the Canadian Motor Vehicle Arbitration Plan (CAMVAP).

CAMVAP uses the services of Provincial Administrators to assist consumers in scheduling and preparing for their arbitration hearings. However, before you can proceed with CAMVAP you must follow your manufacturer's dispute resolution process as outlined under "Service/Maintenance Concerns (U.S. or Canada)" earlier in this chapter.

Consumers wishing to obtain further information about the program can obtain an information booklet from your dealer or contact the Provincial Administrator, Canadian Motor Vehicle Arbitration Plan, at the address or telephone number shown below.

O & P Services

595 Bay Street — Suite 300

Toronto, Ontario

M5G 2C2

Telephone 1 (800) 207-0685

This plan is not available in the province of Quebec.

Getting Help Outside the U.S. and Canada

Before you export your vehicle to a foreign country, contact the appropriate foreign embassy or consulate to make sure local regulations do not prevent you from registering your vehicle. Officials at the embassy can also help you decide whether you should import your vehicle to that country.

Officials at the embassy or consulate can tell you where to get unleaded fuel. If you cannot get unleaded fuel or can get only fuel with an anti-knock index that is lower than your vehicle needs, contact a district or owner relations office before you leave the U.S. or Canada.

Use of leaded fuel in your vehicle without a proper conversion may damage the effectiveness of your emissions control system and may cause engine knocking or serious engine damage. Ford Motor Company is not responsible for any damage that is caused by use of improper fuel.

You may also have difficulty importing your vehicle back into the U.S. if you use leaded fuel.

If your vehicle must be serviced while you are traveling or living in Central or South America, the Caribbean, or the Middle East, contact the nearest Ford dealership. If the dealership cannot help you, write to:

**Ford Motor Company
EXPORT OPERATIONS
1555 Fairlane Drive
Fairlane Business Park #3
Allen Park, Michigan 48101
U.S.A.
Telephone: (313) 317-4282
Fax: (313) 390-0804**

If you are in other foreign countries, contact the nearest Ford dealership. If the dealership cannot help you, they can direct you to the appropriate Ford affiliate office.

If you buy your vehicle in North America and then relocate outside of the U.S. or Canada, register your Vehicle Identification Number and new address with Ford Motor Company Export Operations.

Ford Accessories for Your Vehicle

Ford has many fine products available from your dealer to clean your vehicle and protect its finishes. For best results, use the following, or products of equivalent quality:

- Ford Custom Clear Coat Polish
- Ford Custom Silicone Gloss Polish
- Ford Custom Vinyl Protectant
- Ford Deluxe Leather and Vinyl Cleaner
- Ford Extra Strength Spot and Stain Remover
- Ford Extra Strength Tar and Road Oil Remover
- Ford Extra Strength Upholstery Cleaner
- Ford Extra Strength Whitewall Tire Cleaner
- Ford Multi-Purpose Cleaner
- Ford Premium Car Wash Concentrate
- Ford Triple Clean
- Ford Ultra-Clear Spray Glass Cleaner

A wide selection of accessories is available through your local authorized dealer. These fine accessories have been engineered specifically to fulfill your automotive needs. They are custom designed to complement the style and aerodynamic appearance of your Ford-built vehicle. In addition, each accessory is made from high quality materials and meets or exceeds Ford's rigid engineering and safety specifications. That is why Ford brand accessories are warranted for up to 3 years or 36,000 miles (60,000 km), whichever comes first. See your dealer for complete warranty information and accessory availability.

Safety, Comfort, and Convenience

Safety

Remote keyless entry system
Vehicle security system
Wheel locknuts (anti-theft)

Travel

Heavy-duty battery (standard in Canada)

Comfort and convenience

Cargo net
Engine block heater (standard in Canada)
Speed control

Protection and appearance

Carpeted floor mats
Cleaners, waxes and polishes
Door edge guards
Front end covers
Front end mini-mask
Lubricants and oils
Rear decklid spoiler
Side window deflectors
Step/sill plates
Super Seal fabric protector (in U.S. only)
Super Seal undercoating (in U.S. only)
Touch-up paints
Wheel splashguards (molded)

Accessories

- NOTE:** When adding accessories, equipment, passengers, and luggage to your vehicle, do not exceed the total weight capacity of the vehicle or of the front or rear axle (GVWR, GAWR as shown on the Safety Compliance Certification Label). Consult your dealer for specific weight information.
- NOTE:** The Federal Communications Commission (FCC) or the Canadian Radio Telecommunications Commission (CRTC) regulates the use of mobile communications systems — such as two-way radios, telephones, and theft alarms — that are equipped with radio transmitters. Any such equipment installed in your vehicle should comply with FCC or CRTC regulations and should be installed only by a qualified technician.
- NOTE:** Mobile communications systems may harm the operation of your vehicle, particularly if they are not properly designed for automotive use or are not properly installed. For example, when operated, such systems may cause the engine to stumble or stall. In addition, such systems may themselves be damaged or their operation affected by operating your vehicle. (Citizens band [CB] transceivers, garage door openers, and other transmitters whose power output is 5 watts or less will not ordinarily affect your vehicle's operation.)
- NOTE:** Because we have no control over the installation, design, or manufacture of such systems, Ford cannot assume responsibility for any adverse effects or damage that may result if you use this equipment.

1996 Contour Owner Manual Order Form

PUBLICATION FORM NO.	DESCRIPTION
FCS-12195-96	1996 Contour Service Manual
FCS-12106-96	1996 Powertrain Control/Emission Diagnosis
FCS-12139-96	1996 Car Service Spec. (FWD)
FCS-12253-96	1996 Contour Electrical & Vacuum Troubleshooting Manual
93-VID-OM	Ford and the American Dream (50) Minutes of Historic/Nostalgic Videotape

- **NOTE:** For publications prior to year shown above, write for availability to the address shown below.
- Please allow ample time for postal service delivery.

U.S. RESIDENTS

Make checks payable to: HELM, INCORPORATED

MAIL ORDER TO:

HELM, INCORPORATED
P.O. Box 07150
Detroit, Michigan 48207

OR ORDER TOLL FREE:

1-800-782-4356

Monday - Friday 8:00 A.M. - 6:00 P.M. EST, For Credit Card Holder Orders Only

CANADIAN RESIDENTS

Make cheques payable to: Ford Motor Company of Canada, Ltd.

MAIL ORDER TO:

Ford Motor Company of Canada, Ltd.
Service Publications
P.O. Box 1580, Station B
Mississauga, Ontario, Canada L4Y 4G3

OR ORDER TOLL FREE:

1-800-387-4966

Monday - Friday 8:30 A.M. - 6:00 P.M. EST, For Credit Card Holder Orders Only

Accessories

U.S.
RESIDENTS
USE THIS
PAGE

ORDER TOLL FREE 1-800-782-4356

NOTE: For Credit Card Holder Orders Only Monday-Friday 8:00 A.M.-6:00 P.M. EST

If further information is needed, write to the address shown below or call 1-800-782-4356. Material cannot be returned for credit without receiving advance authorization within 14 days of delivery. On returns, a re-stocking fee may be applied against the original order.

1 9 9 6	PUBLICATION FORM NUMBER	1996 CONTOUR PUBLICATION	QTY.	PRICE EACH	TOTAL PRICE
	FCS-12195-96	Contour SM			
	FCS-12106-96	Powertrain Control/ED		160.00	
	FCS-12139-96	Car Service Spec. (PWD)		32.00	
	FCS-12253-96	Contour EVTm		29.00	
	93-VID-OM	Videotape		19.95	

TOTAL MATERIAL		
Michigan Purchasers add 6% sales tax		
Handling Charge		\$4.00
GRAND TOTAL		

**P
A
Y
M
E
N
T**

Check or Money Order payable to Helm, Inc. (USA funds only - do not send cash.)

MasterCard

VISA Discover

Expiration Date mo/yr: /

Account Number

Check here if billing address is different from shipping address shown.

(CUSTOMER SIGNATURE)

(DATE)

**S
H
I
P
T
O**

NOTE: Dealers and Companies please provide dealer or company name, along with the name of the person to whom the shipment should be sent. For purchases outside U.S.A. and Canada, please write to the following address for quotation. Mail completed order form to: HELM, INC • P.O. Box 07150 • Detroit, MI 48207. Please allow 6-8 weeks for delivery. Prices are subject to change without notice and without incurring obligation.

(CUSTOMER NAME)

(ATTENTION)

(STREET ADDRESS - NO P.O. BOX NUMBERS)

(APT.NO.)

(CITY)

(STATE)

(ZIP CODE)

DAYTIME TELEPHONE AREA CODE () _____

CANADIAN
RESIDENTS
USE THIS
PAGE

ORDER TOLL FREE 1-800-387-4966

NOTE: For Credit Card Holder Orders Only Monday-Friday 8:30 A.M.-6:00 P.M. EST

If further information is needed, write to the address shown below or call 1-800-387-4966. Material cannot be returned for credit without receiving advance authorization within 14 days of delivery. On returns, a re-stocking fee may be applied against the original order.

1 9 9 6	PUBLICATION FORM NUMBER	1996 CONTOUR PUBLICATION	QTY.	PRICE EACH	TOTAL PRICE
		FCS-12195-96	Service Manual		\$ 91.00
	FCS-12106-96	Powertrain Control/ED		160.00	
	FCS-12139-96	Car Service Spec. (FWD)		39.00	
	FCS-12253-96	Electrical & Vacuum T.M.		39.00	

**P
A
Y
M
E
N
T**

Cheques or Money Order payable to Ford Motor Company of Canada, Ltd. (Do not send cash.)

VISA

Expiration Date mo/yr:

Account Number

_____ (CUSTOMER SIGNATURE) _____ (DATE)

TOTAL MATERIAL	
G.S.T. (7%)	
Handling/Shipping Charge Individual Item Order Except Service Manuals \$5.00 OR Service Manuals and Multiple Item Orders \$10.00 (French Owner Guide: No Charge)	
GRAND TOTAL	

Check here if billing address is different from shipping address shown.

**S
H
I
P
T
O**

NOTE: Dealers and Companies please provide dealer or company name, along with the name of the person to whom the shipment should be sent. Mail completed order form to: Ford Motor Company of Canada, Ltd. • Service Publications • P.O. Box 1580, Station B Mississauga, Ontario, Canada L4Y 4G3. Please allow 6-8 weeks for delivery. Prices are subject to change without notice and without incurring obligation.

(CUSTOMER NAME)

(ATTENTION)

(STREET ADDRESS - NO P.O. BOX NUMBERS)

(APT.NO.)

(CITY)

(PROVINCE)

(POSTAL CODE)

DAYTIME AREA
TELEPHONE CODE () _____

Servicing Your Contour

Service Made Easy

Ford has two goals for servicing your vehicle.

1. When we can, we design parts that do not need to be serviced.
2. We want to make servicing your vehicle as easy as possible. To help you:
 - We highlight do-it-yourself items in yellow in the engine compartment so that you can find them easily.
 - When possible, we design parts — such as the headlamp bulbs — that can be replaced without tools.
 - We give you a Maintenance Schedule that makes tracking routine service for your vehicle easy. The maintenance schedule is located in the *Maintenance Schedule and Record* booklet.

This chapter tells you about the basic parts that you need to check and service regularly.

If your vehicle needs professional servicing, your dealership can provide the parts and service required. Check your *Warranty Information Booklet* to find out which parts and services are covered. Also see the *Customer Assistance* chapter of this Owner Guide.

Ford Motor Company recommends that the Owner Maintenance Checks listed in the *Maintenance Schedule and Record* booklet be performed for the proper operation of your vehicle. In addition to the conditions listed in the *Owner Maintenance Checklist*, be alert for any unusual noise, vibration, or other indication that your vehicle may need service. If you do notice something unusual, see that your vehicle is serviced promptly.

Use only recommended fuels, lubricants, fluids, and service parts conforming to Ford specifications. Motorcraft parts are designed and built to provide the best performance in your vehicle. Using these parts for replacement is your assurance that Ford-built quality stays in your vehicle.

NOTE: Always dispose of used automotive fluids in a responsible manner. Follow your community's standards for disposing of these types of fluids. Call your local recycling center to find out about recycling automotive fluids.

Precautions When Servicing Your Vehicle

Be especially careful when inspecting or servicing your vehicle. Here are some general precautions for your safety:

- Do not work on a hot engine. The engine cooling fan may come on unexpectedly. Always turn the engine off and let it cool.

 WARNING
--

<p>The cooling fan is automatic and may come on at any time. Always disconnect the negative terminal of the battery before working near the fan.</p>

- If you must work with the engine running, avoid wearing loose clothing or jewelry that could get caught in moving parts. Take appropriate precautions with long hair.
- Do not work on a vehicle in an enclosed space with the engine running, unless you are sure you have enough ventilation.
- Never get under a vehicle while it is supported by a jack only. If you must work under a vehicle, use safety stands.

Servicing Your Contour

- Keep all lit cigarettes and other smoking materials away from the battery and all fuel-related parts.

Working with the engine off:

1. Set the parking brake fully and make sure that the gearshift is securely latched in P (Park) (automatic transaxle) or 1 (First) gear (manual transaxle).
2. Remove the key from the ignition after you turn the engine off.
3. Block the wheels. This will prevent your vehicle from moving unexpectedly.

Working with the engine on:

1. Set the parking brake fully and make sure the gearshift is securely latched in P (Park) (automatic transaxle) or Neutral (manual transaxle).
2. Block the wheels. This will prevent your vehicle from moving unexpectedly.

 WARNING
--

Do not start your engine with the air cleaner removed and do not remove it while the engine is running.
--

If the battery is disconnected, the computer must relearn its idle control. See *Battery* in the Index.

Opening the Hood

1. Inside the vehicle, pull the hood release handle located under the bottom left corner of the instrument panel.

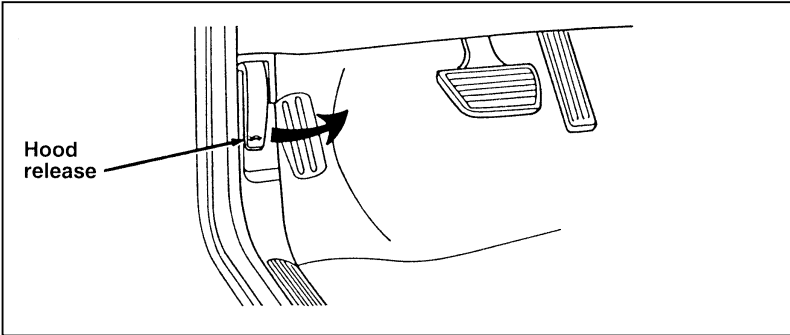

The hood release under the instrument panel

2. Go to the front of the vehicle and release the auxiliary latch that is located under the hood at the center of the vehicle.

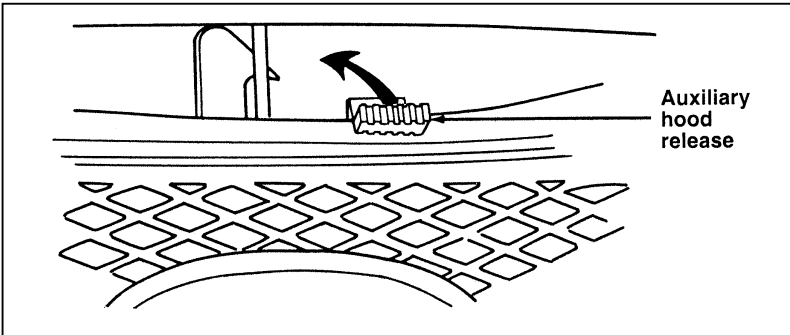

The auxiliary latch under the front edge of the hood

Servicing Your Contour

3. Lift the hood and secure it in the open position with the prop rod. Make sure only the hole in the hood marked in yellow is used.

When you close the hood, make sure the prop rod is in its retainer and that the hood latches securely.

NOTE: Apply lubricant to the hood latch at six-month intervals to maintain smooth and trouble-free operation.

NOTE: Read and understand *Precautions When Servicing Your Vehicle* at the beginning of this chapter before opening the hood.

Engine Compartment

Your vehicle has a 4-cylinder 2.0L EFI or 6-cylinder 2.5L EFI engine.

The 2.0L EFI engine

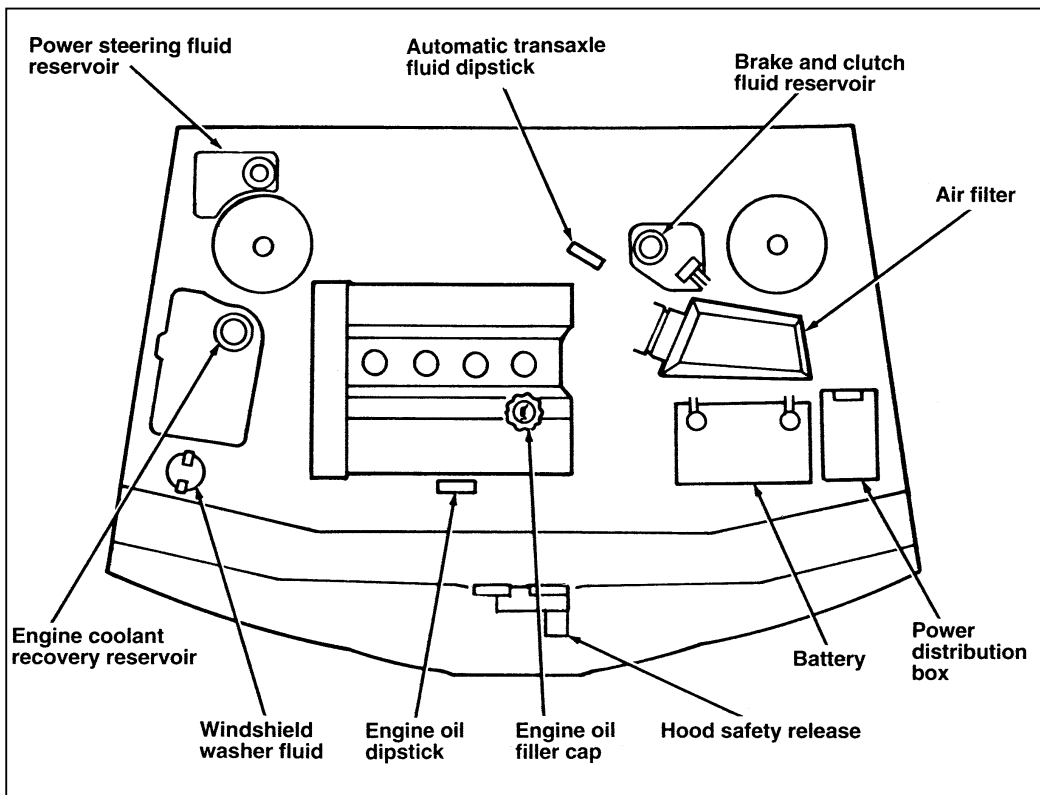

Servicing Your Contour

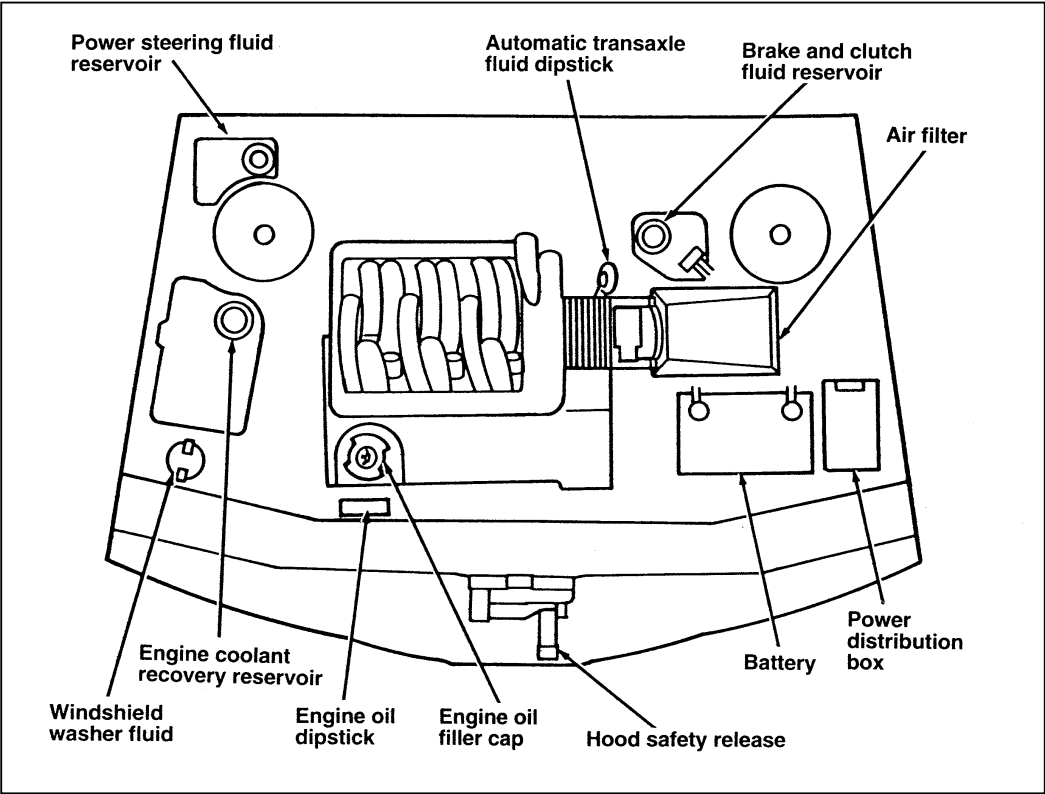

The 2.5L EFI engine

Cleaning the Engine

A clean engine is more efficient because a buildup of grease and dirt acts as an insulator, keeping the engine warmer than usual.

- Extreme care must be used if a power washer is used to clean the engine. The high pressure fluid could penetrate sealed parts and assemblies causing damage or malfunctions.
- In order to avoid possible cracking of the engine block or fuel injection pump, do not spray a hot engine or injection pump with cold water.
- The alternator, distributor and air intake must be covered. Covering these components will help prevent water damage.
- Never wash or rinse the engine while it is running. Water getting into the engine may cause internal damage.

Filling the Fuel Tank

Fuel Filler Door Release (If equipped)

On some models, the fuel filler door cannot be opened from outside the vehicle. To unlatch the fuel filler door, find the front end of the release handle on the floor to the left of the driver's seat. Push the handle down firmly until it stops and the door pops open.

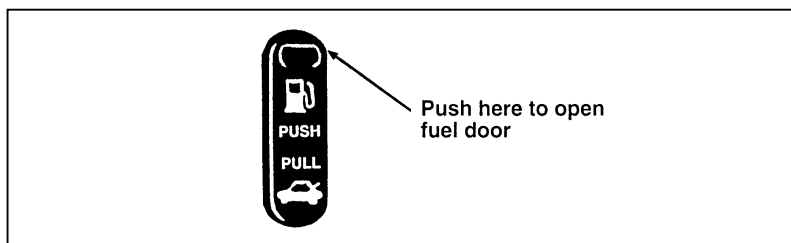

The fuel filler door release

If the fuel filler door does not open when you push the release handle, open the trunk and find the override release on the

Servicing Your Contour

right side. The override release is a handle which is marked with a fuel pump symbol. Open the fuel filler door by pulling on the handle.

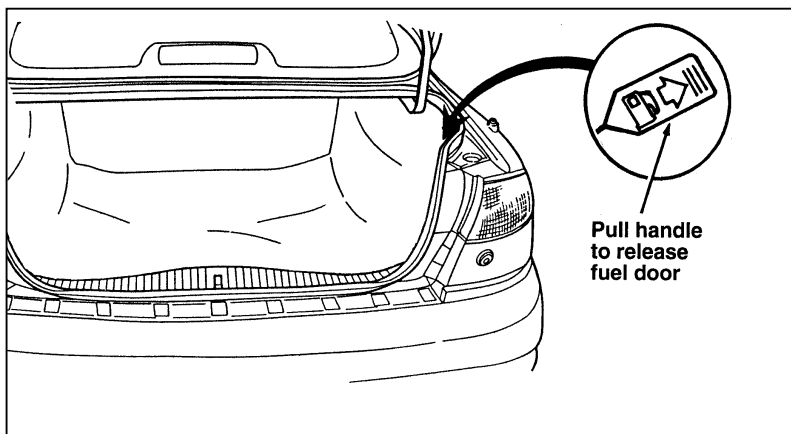

Fuel filler door release — manual override

Filling the fuel tank

The fuel door is outside the car on the passenger side near the back. To fill the fuel tank:

1. After opening the fuel filler door, remove the cap carefully and slowly by turning it counterclockwise $1/2$ to $3/4$ turn. If a hissing sound is heard, wait until it stops, then continue turning until the cap is free.

⚠ WARNING

If the fuel cap is venting vapor or if you hear a hissing sound, wait until it stops before completely removing the cap.

2. Put the nozzle all the way inside the fuel filler pipe before pumping the fuel.

NOTE: If you spill any fuel on the body of your vehicle, clean it off immediately. The fuel may dull or soften the paint if you do not wash it off.

3. Replace the fuel cap completely when you are finished. Turn it clockwise until it is tight. It will click when it is fully tightened.
4. Push the fuel door closed.

If you lose the fuel cap, replace it with an authorized Motorcraft or equivalent part.

⚠WARNING

If you do not use the proper fuel cap, the pressure in the fuel tank can damage the fuel system or cause it to work improperly in a collision.

NOTE: If you replace your fuel cap with an aftermarket fuel filler cap, the customer warranty may be void for any damage to the fuel tank and/or fuel system.

Choosing the Right Fuel

Use only UNLEADED FUEL in your vehicle. Using leaded fuel is prohibited by federal law. Your warranty may not apply if your vehicle is damaged because you used the wrong fuel.

Using a high-quality fuel makes your vehicle more responsive and maintain its good fuel economy and emissions. It should not be necessary to add any aftermarket products to your fuel tank if you continue to use a high-quality fuel.

Octane recommendations

Your engine is designed to use regular fuel with an octane rating of 87. In most cases it is not necessary to use a fuel with an octane rating higher than 87. At service stations, the octane rating is displayed in a label on the pumps.

Servicing Your Contour

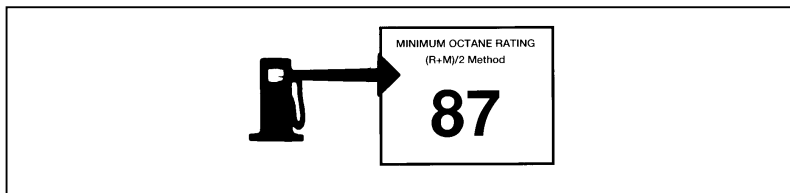

Typical octane rating label

Using a fuel with a lower octane rating can cause persistent and heavy knocking, which can damage the engine.

Do not be concerned if your vehicle sometimes knocks lightly when you drive up a hill or when you accelerate. However, see your dealer or a qualified service technician if persistent heavy knocking occurs because this can damage the engine.

If your vehicle has problems with starting, rough idle or hesitation problems when the engine is cold, it may be caused by fuel with low volatility. Try a different brand of fuel. If the condition persists, see your dealer or a qualified service technician.

Gasolines for clean air

Fuels in certain areas of the country are required to contain oxygenates to improve air quality. Common oxygenates are ethanol or grain alcohol (blended at no more than 10%), methanol or wood alcohol (blended at no more than 5% with cosolvents and additives), and MTBE or methyl tertiary butyl ether (blended at no more than 15%).

Reformulated fuel is also required in certain areas of the U.S. These fuels are designed to further reduce the emissions from your vehicle.

Generally, you should not experience difficulties operating your vehicle on fuels containing oxygenates. We encourage you to use these fuels.

Safety Information Relating to Automotive Fuels

⚠ WARNING

Automotive fuels can cause serious injury or death if misused or mishandled.

- Turn vehicle off when refueling
- Do not smoke when refueling. Fuels are extremely flammable.
- Do not siphon any fuel by mouth.

⚠ WARNING

Gasoline or gasoline blended with methanol can cause blindness and possible death when swallowed. If any fuel is swallowed, call a physician or poison control center immediately.

- Avoid breathing vapors while refueling.
- If fuel is splashed on the skin, wash with soap and water.
- If fuel is splashed in the eyes, remove contact lenses (if worn), flush with water for 15 minutes, and seek medical attention.

Gasoline and gasoline blends may contain small amounts of carcinogens, such as benzene. Long-term exposure to unleaded gasoline vapors has caused cancer in laboratory animals.

If you are taking the medication “Antabuse” or other forms of disulfiram for the treatment of alcoholism, vapor or skin contact with a gasoline-methanol blend may cause the same kind of adverse reaction as drinking an alcoholic beverage. In sensitive

Servicing Your Contour

individuals, serious personal injury or sickness could result. Consult a physician promptly if you experience an adverse reaction.

Running Out of Fuel

NOTE: Avoid running out of fuel because this situation may have an adverse effect on modern powertrain components.

You may need to crank the engine several times before the fuel system starts to pump fuel from the tank to the engine.

 WARNING
--

<p>Never pour fuel in the throttle body or attempt to start the engine with the air cleaner removed. Doing so could result in fire and personal injury.</p>
--

Fuel Economy

Fuel economy is an estimate of the efficiency of your vehicle and can be calculated as Miles Per Gallon (MPG) or Liters Per 100 Kilometers (L/100K).

Do not calculate fuel economy during your vehicle's break-in period. This would not be an accurate estimate of how much fuel your vehicle will normally use.

To calculate fuel economy:

1. Fill the tank completely and record the initial odometer reading.
2. Every time you buy fuel record the amount (in gallons or liters) purchased.
3. After at least three to five tankfuls, fill the fuel tank and record the final odometer reading.

4. Use these equations to calculate your fuel economy:

- English: $\text{MPG} = (\text{total miles driven}) \div (\text{gallons used})$
- Metric: $\text{L}/100\text{k} = (\text{liters used}) \div (100 \text{ kilometers})$

Comparisons With EPA Fuel Economy Estimates

EPA fuel economy figures are obtained from laboratory tests under simulated road conditions and may not reflect the actual conditions you experience or your style of driving. The EPA fuel economy estimate is not a guarantee that you will achieve the fuel economy shown.

The following decrease fuel economy:

- Lack of regular, scheduled maintenance
- Rapid acceleration and excessive speed
- Driving with your foot on the brake
- Sudden stops
- Extended engine idling
- Using speed control in hilly terrain
- Extended use of the A/C, defroster, rear window defroster and other accessories
- Underinflated tires
- Heavy loads
- Aftermarket add-ons such as bike, ski or luggage racks, bug deflectors, etc.

Servicing Your Contour

Self-Service Pointers

If you choose to do your own fueling, you should also perform a few simple maintenance routines. This extra effort will save you additional money and contribute to the driving efficiency of your vehicle.

The following procedures require only a tire gauge, a rag, an oil can spout and windshield washer fluid.

- Check the engine oil at every refueling stop
- Clean the windshield, outside mirrors and headlights
- Check windshield washer fluid
- Check tires for excessive wear or worn edges
- Check the tire pressure at least monthly

Engine Oil Recommendations

We recommend using Motorcraft oil or an equivalent oil meeting Ford Specification ESE-M2C153-E and displaying the American Petroleum Institute CERTIFICATION MARK on the front of the container.

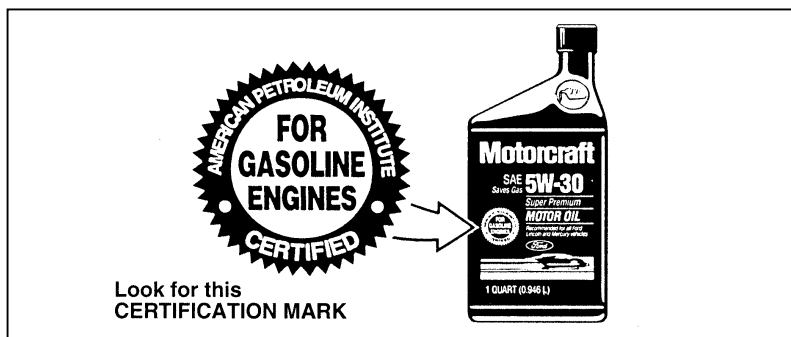

The API Certification Mark

Never use:

- “Non-Detergent” oils
- Oils labeled API SA, SB, SC, SD, SE, SF or SG
- Additional engine oil additives, oil treatments or engine treatments

Engine oils with an **SAE 5W-30** viscosity are **PREFERRED** for your vehicle. They provide the best engine performance, fuel economy and engine protection for all climates down to -15°F (-25°C).

Synthetic engine oils which are **CERTIFIED** and of the preferred viscosity may be used in your engine. The engine oil and oil filter must still be changed according to the maintenance schedule.

Checking and Adding Engine Oil

Since the proper amount of engine oil is important for safe engine operation, check the oil using the dipstick each time you put fuel in your vehicle. Remember the engine must be off, the oil must be warm and the vehicle must be parked on level ground.

Checking the engine oil level:

1. Turn the engine off after it has warmed up and allow a few minutes for the engine oil to drain back into the oil pan.
2. Set the parking brake fully and make sure that the gearshift is securely latched in P (Park) (automatic transaxle) or 1 (First) (manual transaxle).
3. Open the hood. Protect yourself from engine heat.
4. Locate the engine oil dipstick (highlighted in yellow) and carefully pull it out of the engine.

Servicing Your Contour

5. Wipe the dipstick clean and put it back into position, making sure it is fully seated.

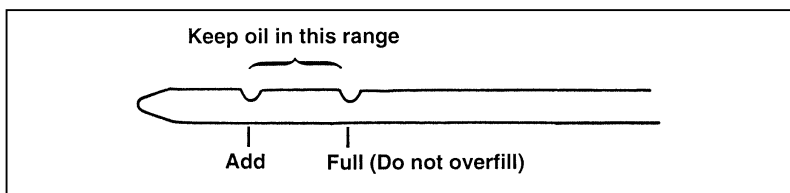

Engine oil dipstick (2.0L engine)

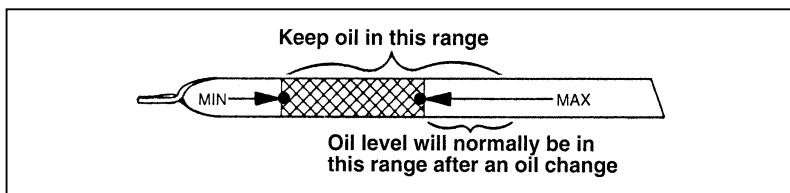

Engine oil dipstick (2.5L engine)

6. **2.0L engine:** Carefully, pull the dipstick out again. If the oil level is below the lower notch, add engine oil as necessary. If the oil level is beyond the upper notch, engine damage and/or high oil consumption may occur and some oil must be removed from the engine.

2.5L engine: Carefully, pull the dipstick out again. If the oil level is below the MIN line, add engine oil as necessary. If the oil level is above the letter M in MAX, engine damage and/or high oil consumption may occur and some oil must be removed from the engine.

7. Put the dipstick back in and make sure it is fully seated.

It may be necessary to add some oil between oil changes. Make sure you use a CERTIFIED engine oil of the preferred viscosity. Your vehicle's warranty coverage may not apply if engine damage is caused by the use of improper engine oil.

Add engine oil through the oil filler cap highlighted in yellow. To add oil, remove the filler cap and use a funnel to pour oil into the opening. Be careful not to overfill the engine. Recheck the oil level after you finish adding oil.

Nearly all engines will consume engine oil. As a result, it may be necessary to add some oil between oil changes.

Changing the Engine Oil and the Oil Filter

Change the engine oil and oil filter per the following, whichever occurs first.

<p>5,000 MILES (8,000 KM) OR 6 MONTHS NORMAL SCHEDULE</p> <hr/>
<p>3,000 MILES (5,000 KM) OR 3 MONTHS SEVERE DUTY SCHEDULE</p> <p>EXTENSIVE IDLING TRAILER TOWING DRIVING IN SEVERE DUST POLICE, TAXI, OR DELIVERY</p>

Refer to the Maintenance Schedule and Record Booklet for additional information.

NOTE: Always dispose of used automotive fluids in a responsible manner. Follow your community's standards for disposing of these types of fluids. Call your local recycling center to find out about recycling automotive fluids.

Servicing Your Contour

⚠ WARNING

Continuous contact with USED motor oil has caused cancer in laboratory mice.

Protect your skin by washing with soap and water.

Engine Coolant

Checking the Engine Coolant

NOTE: Be sure to read and understand *Precautions When Servicing Your Vehicle* at the beginning of this chapter.

⚠ WARNING

The cooling fan is automatic and may come on at any time. Always disconnect the negative terminal of the battery before working near the fan.

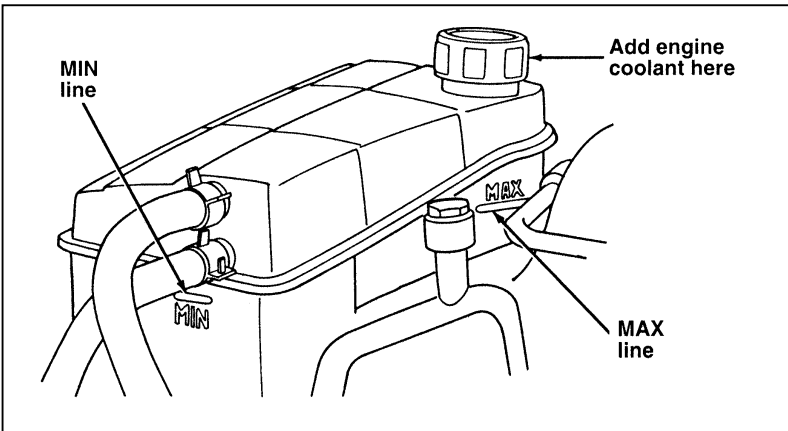

The engine coolant recovery reservoir (2.5L shown — 2.0L similar)

Your vehicle's coolant protects your engine from overheating in the summer and from freezing in the winter. Check the level of the coolant at least once a month. Simply look at the engine coolant reservoir located in the engine compartment. To locate the reservoir, see the diagram of your vehicle's engine under *Engine Type*, in this chapter.

Check the engine coolant level in the engine coolant reservoir at least once a month using the following guidelines.

When your vehicle's engine is cool, the coolant level in the engine coolant recovery reservoir should be at or above the MIN mark. When the engine is hot, the coolant level should be at the MAX mark. If the level is below the indicator mark in either condition, coolant may need to be added.

The coolant additives also protect the entire cooling system from internal passageway corrosion and these additives lubricate the water pump. The coolant should be serviced as noted in the *Maintenance Schedule and Record* booklet.

Adding engine coolant

 WARNING
Do not put engine coolant in the container for the windshield washer fluid.

 WARNING
Never remove the coolant recovery cap while the engine is running or hot.

1. Before you remove the cap, turn the engine off and let it cool. Even when the engine is cool, be careful when you remove the coolant recovery cap.

Servicing Your Contour

2. When the engine is cool, wrap a thick cloth around the cap and turn it slowly counterclockwise to relieve the pressure.
3. Step back while the pressure releases.
4. When you are sure that all the pressure has been released, use the cloth to turn and remove cap.
5. Stand away from the reservoir opening. Hot steam may blow out or hot engine coolant may even splash out.

⚠ WARNING

Failure to follow these instructions could result in serious personal injury from hot engine coolant or steam blowout and/or damage to the engine cooling system or engine.
--

To find out how much engine coolant mixture your vehicle's coolant system can hold, see *Refill capacities for fluids* in the Index.

Have your dealer check the engine cooling system for leaks if you have to add a quart (liter) of engine coolant more than once a month.

Add engine coolant only to the recovery reservoir. If the coolant level is low, add to the reservoir a 50/50 mixture of water and the type of engine coolant that Ford specifies. You may add water by itself only in an emergency, but you should replace it with a 50/50 mixture as soon as possible. Check the engine coolant again the next few times you drive your vehicle.

Ford Premium Cooling System Fluid is an optimized formula that will protect all metals and rubber elastomers used in Ford engines for four years or 50,000 miles (80,000 km). It is not necessary and not recommended to use supplemental coolant additives in your vehicle. These additives may harm your engine cooling system. Follow the recommended service interval for changing your engine coolant.

NOTE: When you change or add engine coolant, it is important to maintain your engine coolant concentration between 40% (-11°F [-24°C]) and 60% (-62°F [-52°C]), depending on your local climate conditions. Below 40% you will lose freeze protection and above 60% your engine may overheat on a warm day.

NOTE: The use of an improper coolant may void your warranty for the engine cooling system. Use only a premium, nationally recognized brand name engine coolant. Do not use alcohol, methanol antifreeze or engine coolant mixed with alcohol or methanol antifreeze. If you do not use the proper coolant, the aluminum engine on your vehicle will corrode.

Ford Motor Company expressly authorizes the Ford Rotunda engine coolant recycling process and chemicals. Use only Ford Rotunda recycled engine coolant or an equivalent recycled engine coolant that is certified by the supplier to meet Ford specification ESE-M97B44-A.

NOTE: Always dispose of used automotive fluids in a responsible manner. Follow your community's standards for disposing of these types of fluids. Call your local recycling center to find out about recycling automotive fluids.

Use Ford Premium Cooling System Fluid or an equivalent engine coolant that meets Ford Specification ESE-M97B44-A.

Servicing Your Contour

Battery

Your vehicle may have a Motorcraft maintenance-free battery. The Motorcraft maintenance-free battery does not require additional water during its life of service. The vents are part of the cover and cannot be removed. For longer, trouble-free operation, keep the top of the battery clean and dry. Also, make certain the battery cables are tightly fastened to the battery terminals.

If you see any corrosion on the battery cables or terminals, remove the cables from the terminal and clean them both with a wire brush. You can neutralize the acid with a solution of baking soda and water. Reinstall the cables when you are done cleaning them, and apply a small quantity of grease to the top of each battery terminal to help prevent corrosion.

Battery Replacement

If your original equipment battery requires replacement (under warranty), it may in some cases be replaced by a Motorcraft low-maintenance battery. The low-maintenance battery has removable vent caps for checking the electrolyte level and for adding water, if needed.

Check your battery's electrolyte level, at least every 12 months or 12,000 miles (20,000 km), in temperatures above 90°F (32°C) and more often in temperatures above 90°F (32°C). Keep the electrolyte in each cell up to the "level" indicator. Do not overfill the battery cell.

If the electrolyte level in your battery gets low, you can add plain tap water to the battery, as long as you don't use hard water, or water with a high mineral or alkali content. If possible, however, try to only fill the battery cell with distilled water. If the battery needs water often, have the charging system checked.

⚠ WARNING

Batteries normally produce explosive gases which can cause personal injury. Therefore, do not allow flames, sparks or lit tobacco to come near the battery. When charging or working near a battery, always cover your face and protect your eyes, and also provide ventilation.

⚠ WARNING

Batteries contain sulfuric acid which burns skin, eyes, and clothing.

If the acid touches someone's skin, eyes, or clothing, immediately flush the area with water for at least 15 minutes. If someone swallows the acid, have him or her drink lots of milk or water first, then Milk of Magnesia, a beaten egg, or vegetable oil. Call a doctor immediately.

⚠ WARNING

Applying too much pressure on the ends when lifting a battery could cause acid to spill. Lift the battery with a carrier or with your hands on the opposite corners.

Help Us Protect Our Environment

Ford Motor Company strongly recommends that used lead-acid batteries be returned to an authorized recycling facility for disposal.



Battery recycling symbol

Servicing Your Contour

Disconnecting the Battery

Because your vehicle engine is electronically controlled by a computer, some control conditions are maintained by power from the battery. If you ever disconnect the battery or install a new battery, you must allow the computer to “relearn” its idle conditions before your vehicle will drive properly. To begin this process, put the gearshift in P (Park) (automatic transaxle) or Neutral (manual transaxle), set the emergency brake, turn off all the accessories, and start the vehicle. Bring the engine to normal operating temperature. Allow the manual transaxle to idle for one minute in Neutral. Allow the automatic transaxle engine to idle for one minute in N (Neutral) and one minute in D (Drive). Perform the previous procedure with the air conditioning (if equipped) on and off (conditions permitting). The relearning process will complete automatically as you drive the vehicle.

If you do not let the engine relearn its idle, the idle quality of your vehicle may be adversely affected until the idle is relearned. Your vehicle will eventually relearn its idle while you drive it, but it takes much longer than if you use the previous procedure.

Windshield Washer Fluid and Wipers

Washer Fluid

Check the level of the windshield washer fluid every time you stop for fuel. The reservoir for washer fluid is located on the passenger’s side of the engine compartment. Visual inspection can determine if the washer fluid is adequate. Do not operate the washer when the reservoir is empty.

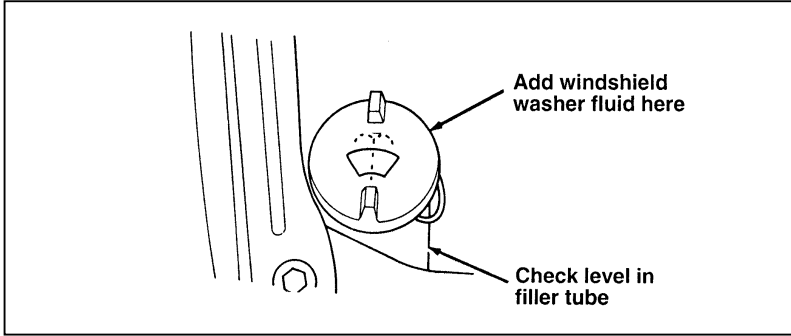

The windshield washer fluid reservoir

Adding washer fluid

⚠ WARNING

Do not put windshield washer fluid in the container for the engine coolant.
--

If sprayed to clean the glass, engine coolant or antifreeze could make it difficult to see through the windshield.

Use specially formulated windshield washer fluid rather than plain water, because specially formulated washer fluids contain additives that dissolve road grime. For safety reasons, washer fluids containing an appropriate antifreeze such as methanol should be used in freezing weather (temperatures below 32°F [0°C]). State or local regulations on Volatile Organic Compounds (VOC's) may restrict use of the most common antifreeze, methanol. Washer fluids containing non-methanol antifreeze agents should be used only if they provide cold weather protection without damaging the vehicle's paint finish, wiper blades, and windshield washer system.

Servicing Your Contour

Wiper Blades

Check the windshield wiper blades at least twice a year. Also check them whenever they seem less effective than usual. Substances such as tree sap and some hot wax treatments used by commercial car washes reduce the effectiveness of wiper blades.

If the blades do not wipe properly, clean both the windshield and the wiper blades. Use undiluted windshield washer solution or a mild detergent. Rinse thoroughly with clear water. Do not use fuel, kerosene, paint thinner, or other solvents to clean your wiper blades. These will damage your blades.

To make reaching the wiper blades easy, simply turn the ignition to the ACC position and turn your wipers on. Wait for them to reach a vertical position and turn the ignition to the OFF position. Do not move the wipers manually. Manually moving the wipers across the windshield may damage them.

Wiper blade replacement

If the wiper blades still do not work properly after you clean them, you may need to replace the wiper blade assembly or the blade element. When replacing the wiper blade assembly, blade refill, or wiper arm always use a Motorcraft part or equivalent. To replace the blades, follow the instructions that come with them.

Passenger Compartment Air Filter Replacement

In your climate control system, you may have a filter that cleans the air before it enters the interior of the vehicle. This filter should be replaced at the intervals in the *Maintenance Schedule and Record* booklet.

To replace the passenger compartment air filter:

1. Remove both windshield wiper arms. With the wiper arm in the horizontal position, lift the arm away from the windshield while pulling the retaining clip at the base toward the windshield. Release the wiper arm, then lift it off the base.

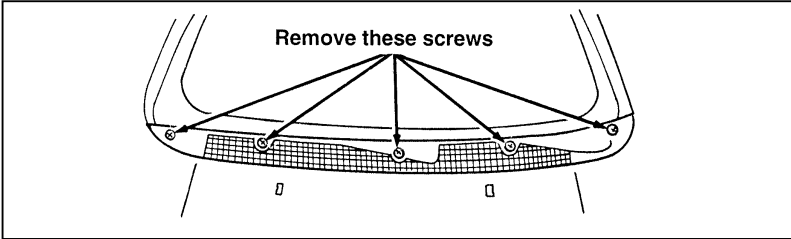

The screws on the grille

2. Remove the plastic caps from the screws on the grille. Remove the screws.
3. Open the hood. Pull off the rubber weatherstrip at the back of the engine compartment. Remove the screws that hold the grille, separate the two halves and remove the grille.

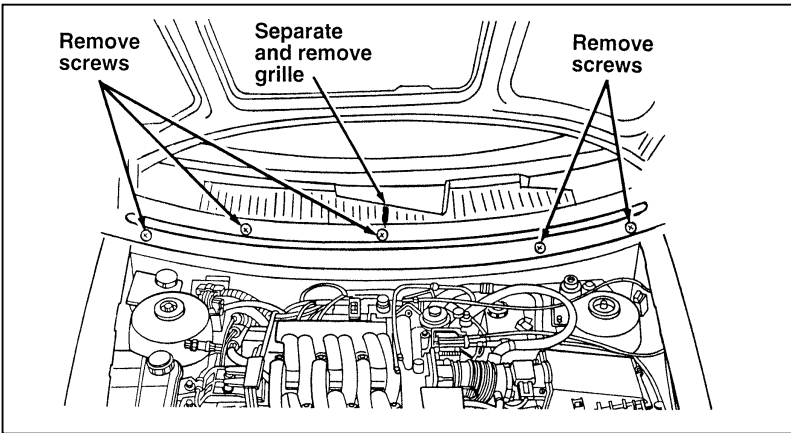

Removing the grille

4. The filter is in a housing at the back of the engine compartment, on the left side. Pull off the two clips on the sides of the housing. Slide out the housing and filter.

Servicing Your Contour

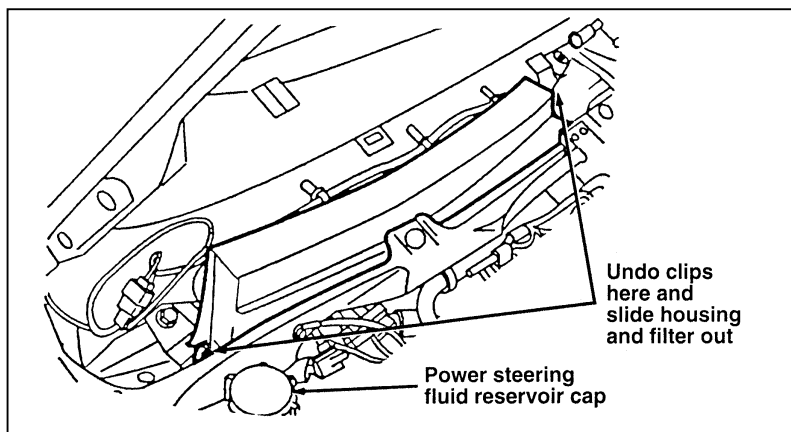

Removing the passenger compartment air filter

5. Slide the filter out of the housing, replace with the new filter, and slide the housing and passenger compartment air filter back into place. Reinstall the clips on the housing.
6. Replace the grille and wiper arms.

Tires

Look at your tires each time you fill your fuel tank. If one tire looks lower than the others, check the pressure in all of them. Always follow these precautions:

- Keep your tires inflated to the recommended pressures.
- Stay within the recommended load limits (see *Load limits* in the Index).
- Make sure the weight of your load is evenly distributed.
- Drive at safe speeds.

If you do not take these precautions, your tires may fail or go flat.

Ford Motor Company recommends obeying posted speed limits.

⚠ WARNING

Driving too fast for conditions creates the possibility of loss of vehicle control. Driving at very high speeds for extended periods of time may result in damage to vehicle components.

At least once a month, check the pressure in all your vehicle's tires, including the spare. Use an accurate tire pressure gauge. Check the tire pressure when tires are cold (after the vehicle has been parked for at least one hour or has been driven less than 3 miles [5 km]). You can find the proper cold pressure and load limits of recommended size tires on the Tire Pressure Decal on the left front door lock facing.

⚠ WARNING

Improperly inflated tires can affect vehicle handling and can fail suddenly, possibly resulting in loss of vehicle control.

Tire Rotation

Because your vehicle's front and rear tires perform different jobs, they often wear differently. To make sure your tires wear evenly and last longer, rotate them as indicated in the following diagram.

Do not include the spare tire as part of your rotation.

If you notice that the tires wear unevenly, have them checked.

Servicing Your Contour

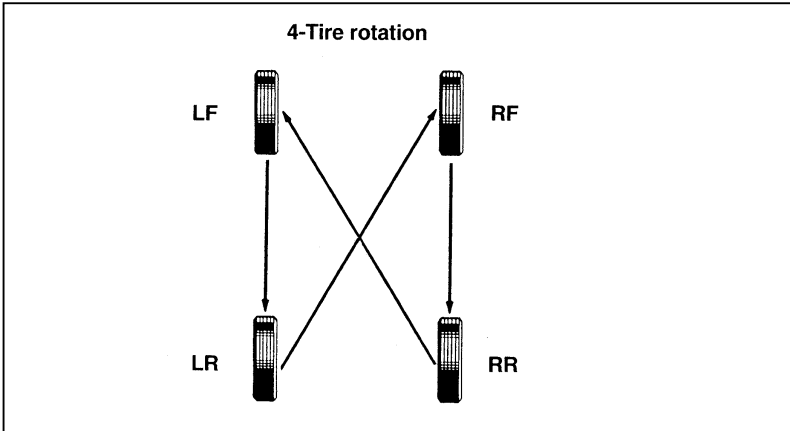

Rotating the tires

Replacing the Tires

Replace any tires that show wear bands. When your tire shows a wear band, it has only 1/16 inch (2 mm) of tread left.

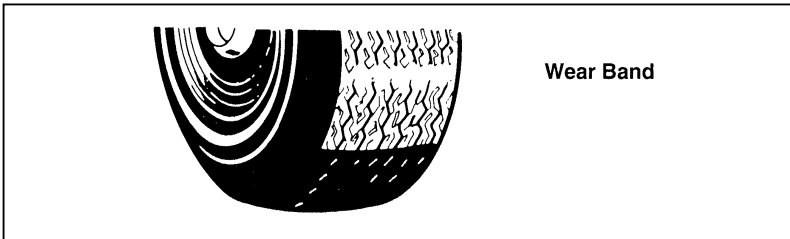

A worn-out tire

Because your vehicle's tires may wear unevenly, you may need to replace them before a wear band appears across the entire tread. Some spots wear more heavily than others.

⚠ WARNING

When replacing full size tires, never mix radial, bias-belted, or bias-type tires. Use only the tire sizes that are listed on the tire pressure decal. Make sure that all tires are the same size, speed rating, and load-carrying capacity. Use only the tire combinations recommended on the decal. If you do not follow these precautions, your vehicle may not drive properly and safely.

Tires that are larger or smaller than your vehicle's original tires may also affect the accuracy of your speedometer.

Information About Tire Quality Grades

New vehicles are fitted with tires that have their Tire Quality Grade (described below) molded into the tire's sidewall. These Tire Quality Grades are determined by standards that the United States Department of Transportation has set.

Tire Quality Grades apply to new pneumatic tires for use on passenger cars. They do not apply to deep tread, winter-type snow tires, space-saver or temporary use spare tires, tires with nominal rim diameters of 10 to 12 inches or limited production tires as defined in Title 49 Code of Federal Regulations Part 575.104(c)(2).

U.S. Department of Transportation — Tire quality grades: The U.S. Department of Transportation requires Ford to give you the following information about tire grades exactly as the government has written it.

Treadwear

The treadwear grade is a comparative rating based on the wear rate of the tire when tested under controlled conditions on a specified government test course. For example, a tire graded 150 would wear one and one-half (1 1/2) times as well on the government course as a tire graded 100. The relative

Servicing Your Contour

performance of tires depends upon the actual conditions of their use, however, and may depart significantly from the norm due to variations in driving habits, service practices and differences in road characteristics and climate.

Traction A B C

The traction grades, from highest to lowest, are A, B, and C, and they represent the tire's ability to stop on wet pavement as measured under controlled conditions on specified government test surfaces of asphalt and concrete. A tire marked C may have poor traction performance. **Warning:** The traction grade assigned to this tire is based on braking (straightahead) traction tests and does not include cornering (turning) traction.

Temperature A B C

The temperature grades are A (the highest), B, and C, representing the tire's resistance to the generation of heat and its ability to dissipate heat when tested under controlled conditions on a specified indoor laboratory test wheel. Sustained high temperature can cause the material of the tire to degenerate and reduce tire life, and excessive temperature can lead to sudden tire failure. The grade C corresponds to a level of performance which all passenger car tires must meet under the Federal Motor Vehicle Safety Standard No. 109. Grades B and A represent higher levels of performance on the laboratory test wheel than the minimum required by law. **Warning:** The temperature grade for this tire is established for a tire that is properly inflated and not overloaded. Excessive speed, underinflation, or excessive loading, either separately or in combination, can cause heat buildup and possible tire failure.

Snow Tires and Chains

During the winter months in some climates, you may need to use snow tires and occasionally chains for your tires.

 WARNING
--

Snow tires must be the same size and grade as the tires you currently have on your vehicle.
--

Use chains on the tires only in an emergency or if the law requires them where you live. If you choose to use chains on your vehicle's tires, be aware of the following:

- Tire chains may scratch or chip aluminum wheels. **IT IS RECOMMENDED THAT TIRE CHAINS ARE INSTALLED ON STEEL WHEELS ONLY.** Be sure to remove wheel covers (if equipped) from steel rims before using tire chains to avoid scratches or damage.
- Tire chains cannot be fitted with 205/60R tires.
- Local regulations may prohibit or restrict the use of tire chains. Investigate the laws and regulations in your area before installing chains.
- Put the chains on the front tires tightly with the ends held down securely. Retighten the chains after driving 1/2 mile (1 km). Follow the chain manufacturer's instructions.
- Do not drive faster than 30 mph (50 km/h) or the chain manufacturer's recommended speed limit, whichever is lower. Avoid bumps, holes and sharp turns. If you can hear the chains rub or bang against your vehicle, remove the chains to prevent damage to your vehicle.
- Tire chains may affect vehicle handling. Drive carefully and avoid hard braking.
- Do not use chains on temporary spare tires. They may damage the vehicle and the tire.

Servicing Your Contour

- Remove tire chains at the first opportunity after using them on snow and ice. Do not use the chains on dry roads.

Cleaning the Wheels

Wash the wheels with the same detergent you use to wash your vehicle's body. Do not use acid-based wheel cleaners, steel wool, abrasives, fuel, or strong detergents. These substances will damage protective coatings. Use tar and road oil remover to remove grease and tar.

NOTE: Before going to a car wash, find out if the brushes are abrasive.

Automatic Transaxle Fluid

Under normal circumstances, you do not need to check the fluid level of the transaxle, since your vehicle does not use up transaxle fluid. Refer to the *Maintenance Schedule and Record* booklet for replacement intervals. However, if the transaxle is not working properly — for instance, the transaxle may slip or shift slowly, or you may notice some sign of fluid leakage — the fluid level should be checked.

Checking the Automatic Transaxle Fluid

With the vehicle on a level surface and the brake fully applied, start the engine and move the gear shift selector through all of the gears allowing sufficient time for each position to engage. Securely latch the gear shift selector in the P (Park) position. Fully set the parking brake and leave the engine running.

Wipe off the dipstick cap and pull the dipstick out. Wipe the indicator end clean. Put the dipstick back into the filler tube and make sure it is fully seated. Pull the dipstick out and read the fluid level.

NOTE: Your vehicle should not be driven until some fluid has been added if the fluid level is below the bottom dimple on the dipstick and the outside temperature is above 50°F (10°C). Add only enough fluid to bring the level above the bottom hole.

If the vehicle has not been driven and the fluid level is above the bottom dimple on the dipstick, do not add fluid. Recheck the fluid level after your vehicle has reached normal operating temperature.

Normal operating temperature is reached after driving approximately 20 miles (30 km). The fluid level should be within the crosshatched area on the dipstick.

NOTE: If the vehicle has been operated for an extended period at high speeds, driven in city traffic during hot weather, or has been pulling a trailer, the vehicle should be turned off for about 30 minutes to allow the fluid to cool before checking.

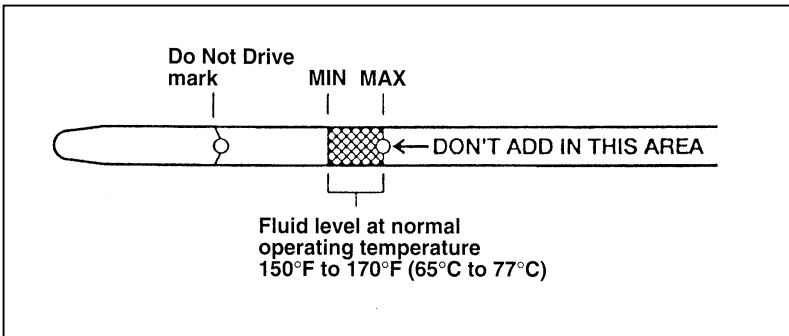

Automatic transaxle fluid dipstick

Servicing Your Contour

Adding Automatic Transaxle Fluid

Before adding any fluid, be sure that the correct type will be used. Correct type is shown on the dipstick.

Add fluid in 1/2 pint (.25L) increments through the filler tube to bring the level to the correct area on the dipstick. DO NOT OVERFILL. If the level is above the top hole on the dipstick, excess fluid should be removed by a qualified technician.

NOTE: Always dispose of used automotive fluids in a responsible manner. Follow your community's standards for disposing of these types of fluids. Call your local recycling center to find out about recycling automotive fluids.

Manual Transaxle Fluid

The lubricant level and quality should not deteriorate under normal driving conditions. However, you should have the fluid level checked occasionally. If lubricant is required, see *Lubricant Specifications* in this chapter.

Brake Fluid

Under normal circumstances, your vehicle should not use up brake fluid rapidly. However, expect the level of the brake fluid to slowly fall as you put more mileage on your vehicle and the brake lining wears.

You should check the brake fluid at every scheduled engine oil change, but be sure to check it at least once a year. You can do this by looking at the fluid level in the plastic reservoir on the master cylinder. (See *The Engine Types* in this chapter to locate the brake fluid reservoir.) The fluid level should be at or near the MAX mark.

 WARNING
--

Brake fluid is toxic.

If brake fluid contacts eyes, flush eyes with running water for 15 minutes. Get medical attention if irritation persists. If taken internally, drink water and induce vomiting. Get medical attention immediately.

If the fluid is low, carefully clean and remove the cap from the reservoir. Fill the reservoir to the MAX line with Ford High Performance DOT 3 Brake Fluid C6AZ-19542-AA or equivalent DOT 3 fluid meeting Ford specification ESA-M6C25-A.

 WARNING
--

If you use a brake fluid that is not DOT 3, you will cause permanent damage to your brakes.
--

Do not fill the reservoir above the MAX line.

Servicing Your Contour

If you find that the fluid level is excessively low — below the seam or ridge on the outside of the plastic reservoir — have the brake system inspected.

⚠ WARNING

**Do not let the reservoir for the master cylinder run dry.
This may cause the brakes to fail.**

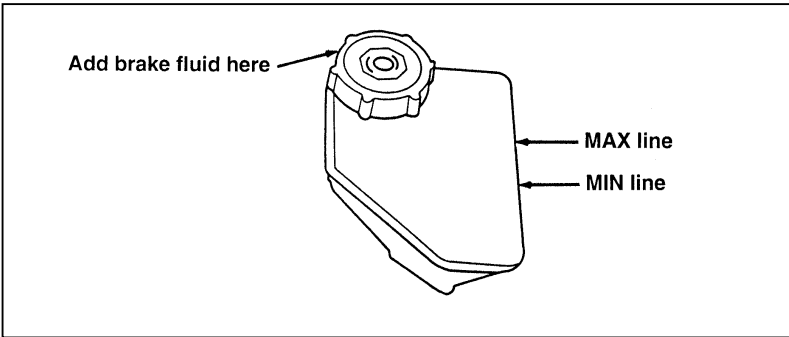

The brake fluid reservoir

Power Steering Fluid

Checking and Adding Power Steering Fluid

With the power steering system at operating temperature, switch off the engine. The fluid level should be up to the MAX marking on the transparent reservoir.

If it drops to or below the MIN mark, top off with the specified fluid.

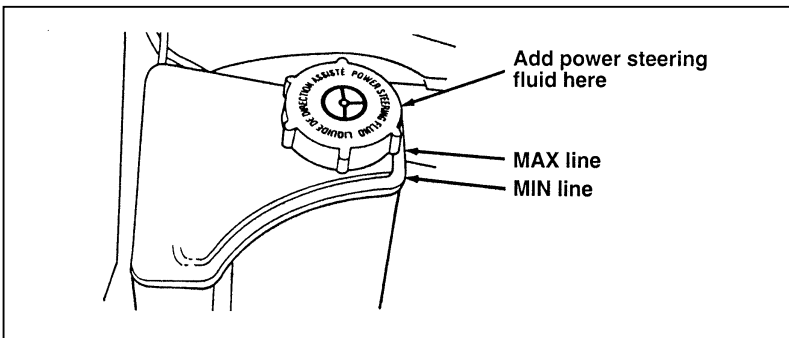

The power steering fluid reservoir

Use only power steering fluid that meets Ford's Specification ESW-M2C33-F or is an equivalent Type F Automatic Transmission Fluid with a Ford registration number (an 8-digit number beginning with "2P" printed on the fluid container).

Servicing Your Contour

Fuses, Circuit Breakers and Relays

Fuses, circuit breakers, and relays protect your vehicle's electrical system from overloading. If electrical parts in your vehicle are not working, the system may have been overloaded and blown a fuse or relay, or tripped a circuit breaker. Before you replace or repair any electrical parts, check the appropriate circuit protector.

The following charts tell you which circuit protector protects each electrical part of your vehicle. If a fuse blows or a circuit breaker opens a circuit, all the parts of your vehicle that use the circuit will not work.

Once you have determined which fuses or circuit breakers to check, follow the procedures under *Checking and replacing fuses* or *Checking and replacing circuit breakers* later in this chapter.

⚠ WARNING
Always remove the key from the ignition before working on or replacing fuses.

The Power Distribution Box Fuses and Relays

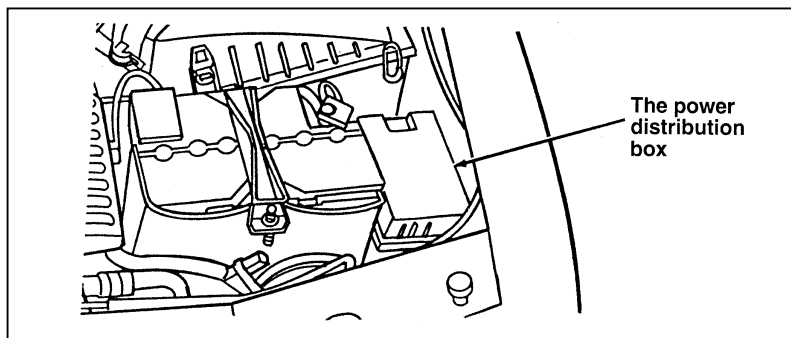

The power distribution box location

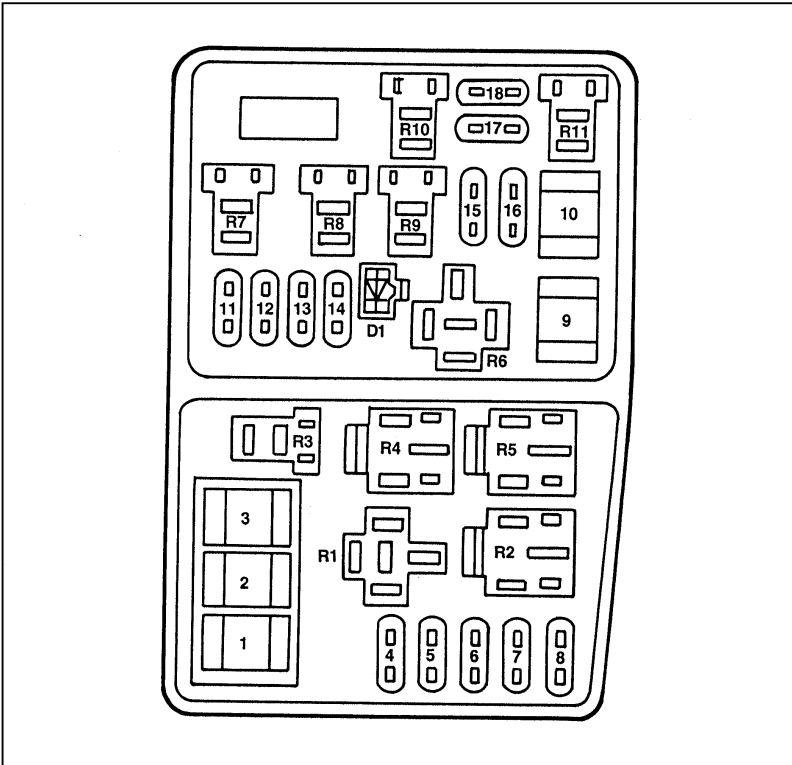

The power distribution box fuses and relays

Spare fuses are located in the power distribution box under the hood.

Servicing Your Contour

Fuse/Relay Location	Fuse Amp Rating	Description
1*	80	• Main power supply
2*	60	• Engine cooling fan
3*	60	• ABS braking system
4	20	• Daytime running lights • Ignition
5	15	• Fog lamp
6	(not used)	
7	30	• ABS braking system
8	30	• Air pump
9	20	• EEC module
10	20	• Ignition switch
11	3	• EEC memory
12	15	• Hazard flashers • Horn
13	15	• HEGO sensor
14	15	• Fuel pump
15	10	• Right low beam
16	10	• Left low beam
17	10	• Right high beam
18	10	• Left high beam

*Have these fuses replaced by a qualified technician

Fuse/Relay Location	Relay Color	Description
R1	white	• Daytime running lights (Canada)
R2	black	• High speed engine cooling fan
R3	blue	• A/C wide open throttle
R4	yellow	• A/C clutch relay
R5	dark green	• Engine cooling fan
R6	yellow	• Starter
R7	brown	• Horn
R8	brown	• Fuel pump
R9	white	• Low beam
R10	white	• High beam
R11	brown	• PCM module
D1	black	• Reverse voltage protection

Servicing Your Contour

The Instrument Panel Fuses, Circuit Breakers and Relays

The instrument panel fuse panel is underneath the instrument panel on the left side. To open it, reach under the instrument panel and push the release button to the right of the fuse panel.

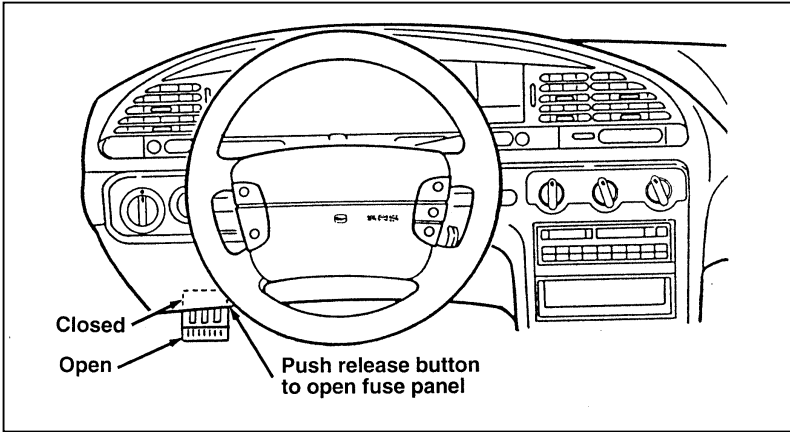

The instrument panel fuse panel location

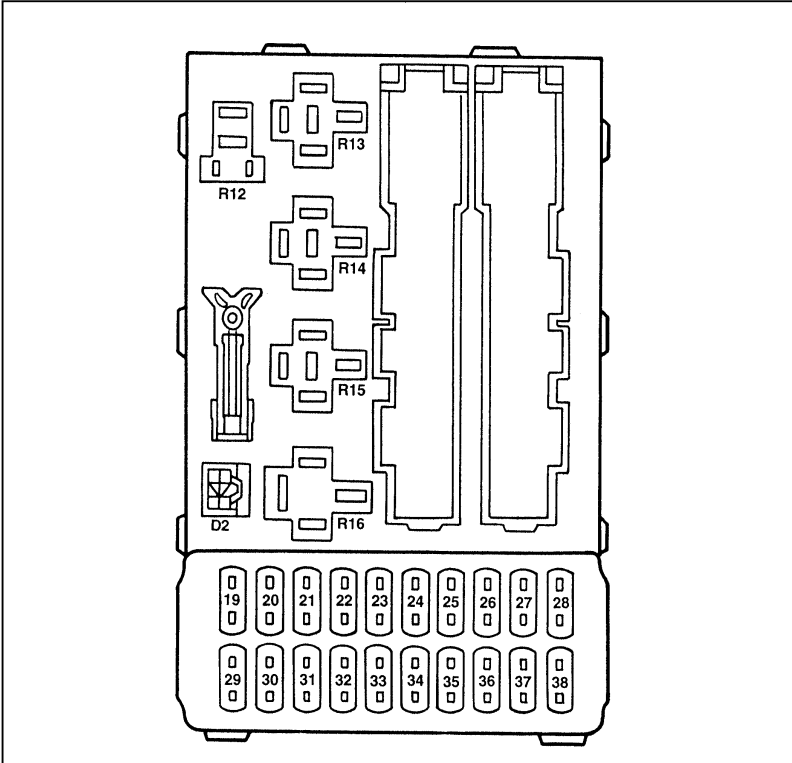

The instrument panel fuses

Servicing Your Contour

Fuse/Relay Location	Fuse Amp Rating	Description
19	7.5	• Heated rear view mirrors
20	10A CB	• Wipers
21	40	• Power windows
22	7.5	• ABS module
23	15	• Backup lamps
24	15	• Brakelamps
25	20	• Door locks
26	7.5	• Main light
27	15	• Cigar lighter
28	30	• Power seats
29	30	• Rear window defrost
30	7.5	• Engine management system
31	7.5	• Instrument panel illumination
32	7.5	• Radio
33	7.5	• Left-hand parking lamps
34	7.5	• Courtesy lamps
35	7.5	• Right-hand parking lamps
36	10	• Air bag
37	30	• Blower motor
38	(not used)	
R12	white	• Courtesy lights
R13	yellow	• Rear window defroster
R14	yellow	• Heater fan motor
R15	green	• Wipers
R16	black	• Ignition
D2	black	• Reverse voltage protection

Relays Outside the Fuse Boxes

Relay Location	Relay Color	Description
R17	(not used)	
R18	black	• Express down windows
R19	blue	• Speed control cut-out
R20	(not used)	
R21	(not used)	
R22	white	• Fog lamps
R23	black	• Turn signal
R24	white	• Left panic alarm flasher
R25	white	• Right panic alarm flasher
R26	(not used)	
R27	(not used)	
R28	(not used)	
R29	brown	• Door lock control

Checking and Replacing Fuses

1. Use the charts to decide which fuse you should check.
2. On the fuse panel decal located on the cover of the power distribution box or on the end of the instrument panel fuse panel, find the number of the fuse you want to check.
3. Find the corresponding fuse and remove it with the fuse pulling tool that is provided.
4. Check the fuse to see if it is blown. Look through the clear side of the fuse to see if the metal wire inside is separated. If it is, the fuse should be replaced.
5. Replace the fuse with one that has the right amperage rating. See the following chart.

Servicing Your Contour

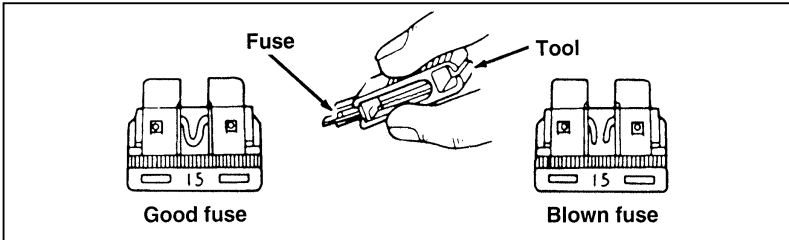

The side view of a typical fuse

Fuse Color	Amperage
Violet	3A
Brown	7.5A
Red	10A
Blue	15A
Yellow	20A
Natural	25A
Green	30A
Amber	40A

⚠ WARNING

Always replace a fuse with one that has the specified amperage rating. Using a fuse with a higher amperage rating can cause severe wire damage and could start a fire.

Circuit Breakers

If you need to check a circuit breaker that is on the instrument panel fuse panel, see *Checking and replacing fuses* to find out how to locate the fuse panel and pull it down.

Diagnostic equipment is needed to check circuit breakers. Refer to the manufacturer's instructions.

Circuit breakers will reset themselves and allow the electrical parts to work again once the overload on the circuit is gone. If

the circuit breakers continue to cut off electricity, have your vehicle's electrical system checked.

If you replace a circuit breaker, use one with the same amperage rating. To remove a circuit breaker mounted in the fuse panel, grip it with your finger and thumb and pull it straight out of its socket.

Lights and Bulb Replacement

It is a good idea to check the operation of the following lights frequently:

- headlamps
- tail lamps
- brakelamps
- high-mount brakelamp
- hazard flasher
- turn signals
- side markers
- license plate lamp

The alignment of your headlamps should be checked if:

- oncoming motorists frequently signal you to turn off your vehicle's high beams when you do not have the high beams on
- the headlamps do not seem to give you enough light to see clearly at night
- the headlamps are not aligned so that they point slightly down and to the right.

Servicing Your Contour

Headlamp Bulb

The headlamps on your vehicle use replaceable bulbs, one for high beam and one for low beam on each side. When the lamp burns out, simply replace the bulb, rather than the whole lamp.

 WARNING
--

<p>Handle a halogen headlamp bulb carefully and keep out of children's reach. Grasp the bulb only by its plastic base and do not touch the glass. The oil from your hand could cause the bulb to break the next time the headlamps are operated.</p>

Do not remove the burned-out bulb unless you can immediately replace it with a new one. If a bulb is removed for an extended period of time, contaminants may enter the headlamp housing and affect its performance.

Removing the headlamp bulb

1. Make sure that the headlamp knob is in the OFF position.
2. Lift the hood and find the bulb in the headlamp socket.
3. Remove the bulb assembly by turning it clockwise and pulling it out of the headlamp socket.
4. Remove the L-shaped bulb by pressing the retaining clip at the base of the electrical connector and sliding the bulb out.

Installing the headlamp bulb

1. Without touching the glass on the bulb, insert the new bulb. You may want to protect the bulb by holding it with a piece of cloth or paper towel. Make sure the retaining clip at the base of the electrical connector locks.
2. Insert the bulb assembly in the headlamp socket. Turn it counterclockwise to lock it in place.

-
3. Turn the headlamps on and make sure that they work properly. If the headlamp was correctly aligned before you changed the bulb, you should not need to align it again.

High-Mount Brakelamp Bulbs

From the back seat, remove the back of the brakelamp assembly. Depress the two retaining tabs on the ends of the assembly and pull off the back.

Turn the burned-out bulb counterclockwise and pull it out. Push in the replacement bulb and turn it clockwise to lock it in the socket. Replace the back of the brakelamp assembly, making sure that the retaining tabs snap into place.

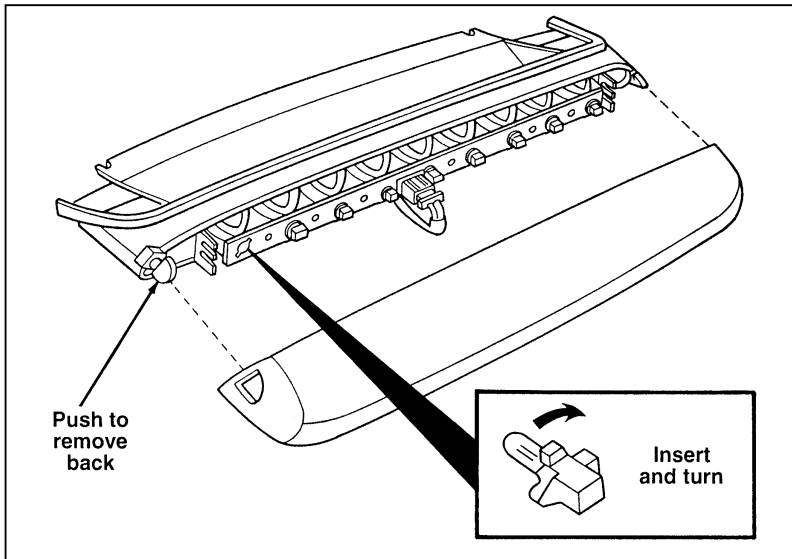

The high-mount brakelamp assembly

Servicing Your Contour

Using the Right Bulbs

Function	Trade Number
Tail lamp, brakelamp, turn lamp	1157
Backup lamp	1156
Front park, turn lamp	2357NA
Headlamp Low beam	9006
High beam	9005
Fog Lamp	893
License plate lamp	C5W
High-mount brakelamp	2723
Dome/Map lamp	**
Door courtesy lamp	168
Engine compartment lamp	89
Floor console	168
Luggage compartment lamp	**
Glove box	168
Instrument courtesy lamps	**
High beam indicator	51A
I/P Ashtray lamp	Not available at time of printing. See your dealer for replacement.
Radio illumination	*
Clock	**
Warning lights (all)	51A
Turn signal indicator	51A
"PRND21"	161
Heater or heater A/C	Not available at time of printing. See your dealer for replacement.
Light switch illumination	161

*Refer bulb replacement to a Ford authorized radio service center.

NA means Natural Amber

**Refer bulb replacement to a Ford authorized dealer.

Emission Control System

Your vehicle is equipped with a catalytic converter which enables your vehicle to comply with applicable exhaust emission requirements.

⚠ WARNING

<p>Exhaust leaks may result in the entry of harmful and potentially lethal fumes into the passenger compartment. Under extreme conditions excessive exhaust temperatures could damage the fuel system, the interior floor covering, or other vehicle components, possibly causing a fire.</p>
--

To make sure that the catalytic converter and the other emission control parts continue to work properly:

- Use only unleaded fuel.
- Avoid running out of fuel.
- Do not turn off the ignition while your vehicle is moving, especially at high speeds.
- Have the services listed in the *Maintenance Schedule and Record* booklet performed according to the specified schedule. The scheduled maintenance services are required because they are considered essential to the life and performance of your vehicle and to its emissions system.

Ford strongly recommends the use of genuine Ford replacement parts. If other than Ford or Motorcraft parts or Ford authorized remanufactured parts are used for maintenance replacements or for the service of components affecting emission control, such non-Ford parts should be equivalent to genuine Ford Motor Company parts in performance and durability. It is the owner's responsibility to determine the equivalency of such parts. Please consult your warranty booklet for complete warranty information.

Servicing Your Contour

WARNING

Do not park, idle, or drive your vehicle in dry grass or other dry ground cover. The emission system heats up the engine compartment and exhaust system, which can start a fire.

Watch for fluid leaks, strange odors, smoke, loss of oil pressure, the charge warning light, the check engine light, or the temperature warning light. These sometimes indicate that the emission system is not working properly.

Do not make any unauthorized changes to your vehicle or engine. Changes that cause more unburned fuel to reach the exhaust system can increase the temperature of the engine or exhaust system.

By law, anyone who manufactures, repairs, services, sells, leases, trades vehicles, or supervises a fleet of vehicles is not permitted to intentionally remove an emission control device or prevent it from working. In some of the United States and in Canada, vehicle owners may be liable if their emission control device is removed or is prevented from working.

Do not drive your vehicle if it does not operate properly. See your dealer if the engine runs on for more than five seconds after you shut it off or if it misfires, surges, stalls, or backfires.

Information about your vehicle's emission control system is on the Vehicle Emission Control Information decal located on or near the engine. This decal identifies engine displacement and gives some tune-up specifications.

Readiness for Inspection/Maintenance Testing

In some localities it may become a legal requirement to pass an Inspection/Maintenance (I/M) test of the On-Board Diagnostic (OBD) II system. If the vehicle's powertrain system or its battery has just been serviced, the OBD II system is reset to a not ready for I/M testing condition. To prepare for I/M testing, the law specifies a "need for additional mixed city and highway driving to complete the check" of the OBD II system. As soon as all of the OBD II system checks are successfully completed, the OBD II system is set to the ready condition. The amount of driving required to reach the ready condition varies with individual driving patterns. To complete this requirement in the minimum amount of time, refer to the OBD II Drive Cycle defined below. If the vehicle owner cannot or does not want to do the additional driving required by law, a service center can perform this drive cycle as it would any other type of repair work.

OBD II Drive Cycle

The following steps must be run in the order shown. If any steps are interrupted, repeat the preceding step. Any safe driving mode is acceptable between steps.

Always drive vehicle in safe manner according to traffic conditions and obey all traffic laws.

The engine must be warmed up and at operating temperature before proceeding with the drive modes of the following OBD II Drive Cycle.

1. Start the engine. Drive or idle (in neutral) the vehicle for 4 minutes.
2. Idle the vehicle in Drive (Neutral for manual transaxle) for 40 seconds.
3. Accelerate the vehicle to 45 mph (70 km/h) at 1/4 to 1/2 throttle for 10 seconds.

Servicing Your Contour

4. Drive the vehicle with a steady throttle at 45 mph (70 km/h) for 30 seconds.
5. Idle the vehicle in Drive (Neutral for manual transmissions) for 40 seconds.
6. Continue to drive the vehicle in city traffic at speeds between 25 and 40 mph (40-60 km/h) for 15 minutes. During the 15 minute drive cycle the following modes must be achieved:
 - a. at least 5 stop and idle modes at 10 seconds each
 - b. acceleration from idles at 1/4 to 1/2 throttle position, and
 - c. choose 3 different speeds to do 1.5 minute steady state throttle drives.
7. Accelerate the vehicle up to between 45 and 60 mph (70-100 km/h). This should take approximately 5 minutes.
8. Drive vehicle and hold the throttle steady at the selected speed between 45 and 60 mph (70-100 km/h) for approximately 5 minutes.
9. Drive the vehicle for 5 minutes at varying speeds between 45 and 60 mph (70-100 km/h).
10. Bring the vehicle back to idle. Idle in Drive for 40 seconds.
11. OBD II drive cycle has been completed. Vehicle can be turned off when convenient.

Refill Capacities, Motorcraft Parts, and Lubricant Specifications

Refill Capacities

Component	U.S.	Metric
Cooling System (including heater)		
Automatic Overdrive		
2.0L	7.5 qts.	7.1 liters
2.5L	9.1 qts.	8.6 liters
5-speed Manual		
2.0L	7.0 qts.	6.6 liters
2.5L	8.9 qts.	8.4 liters
Engine Oil (with filter change)		
2.0L Engine	4.5 qts.	4.3 liters
2.5L Engine	5.5 qts.	5.2 liters
Fuel Tank	14.5 gallons	55.0 liters
Radiator Cap	16 psi	110 kPa
Transaxle		
Automatic Overdrive		
2.0L	9.0 qts.	8.5 liters
2.5L	10.3 qts.	9.7 liters
5-speed Manual	5.5 pts.	2.6 liters

Servicing Your Contour

Motorcraft Parts

Component	Part Number	
	2.0L Engine	2.5L Engine
Spark plug*	AZFS-22PP**	AWSF-32F
Air filter	FA-1612	FA-1613
Passenger compartment air filter	FP-1	FP-1
Fuel filter	FG-800A	FG-800A
Oil filter	FL-200	FL-820
Battery	BX-96R	BXT-40R
PCV valve	EV-224	EV-152
Crankcase ventilation filter	FA-1621	—

*Refer to Vehicle Emission Control Information (VECI) decal for spark plug and gap specifications.

**If a spark plug is removed for examination, it must be reinstalled in the same cylinder. If a spark plug needs to be replaced, use only spark plugs with the service part number suffix letter "PP" as shown on the engine decal.

Lubricant Specifications

ITEM	FORD PART NAME	FORD PART NO.	FORD SPECIFICATION
Brake Master Cylinder	Ford High Performance DOT3 Brake Fluid	C6AZ-19542-AA	ESA-M6C25-A
Constant Velocity Joints	CV Joint Grease — High Temp.	E43Z-19590-A	ESP-M1C207-A
Door Weatherstrips	Silicone Lubricant	COAZ-19553-AA	ESR-M13P4-A
Engine Coolant	Ford Premium Cooling System Fluid	E2FZ-19549-AA CXC-8-B*	ESE-M97B44-A
Engine Oil	Motorcraft Super Premium 5W30	XO-5W30-QSP	ESE-M2C153-E and API Certification Mark
Hinges and Latches	Multi-Purpose Grease Spray	D7AZ-19584-AA	ESR-M1C159-A ESB-M1C93-A
Lock Cylinders	Ford Penetrating Lubricant	E8AZ-19A501-B	—
Power Steering Pump Reservoir	Motorcraft Type F Power Steering Fluid	E6AZ-19582-AA	ESW-M2C33-F
Transaxle Automatic Overdrive	Motorcraft MERCON®	XT-2-QDX	MERCON® ATF
Transaxle 5-Speed Manual	Motorcraft MERCON®	XT-2-QDX	MERCON® ATF
Windshield Washer Reservoir	Ultra-clear Windshield Washer Concentrate	C9AZ-19550-AA or C9AZ-19550-BA	ESR-M17P5-A

* Canada

Servicing Your Contour

Vehicle Storage

Maintenance Tips

If you plan on storing your vehicle for an extended period of time (60 days or more), refer to the following maintenance recommendations to ensure your vehicle stays in good operating condition.

General

- Store all vehicles in a dry, ventilated place.
- Protect from sunlight, if possible.
- If vehicles are stored outside, they require regular maintenance to protect against rust and damage.

Body

- Wash vehicle thoroughly to remove dirt, grease, oil, tar or mud from exterior surfaces, rear wheel housing and underside of front fenders.
- Periodically wash vehicles stored in exposed locations.
- Touch-up raw or primed metal to prevent rust.
- Cover chrome and stainless steel parts with a thick coat of auto wax to prevent discoloration. Re-wax as necessary when the vehicle is washed.
- Lubricate all hood, door and trunk lid hinges and latches with a light grade oil.
- Cover interior soft trim to prevent fading.
- Keep all rubber parts free from oil and solvents.

Engine

- Start engine every 15 days. Run at fast idle until it reaches normal operating temperature.
- With your foot on the brake, shift through all the gears while the engine is running.

Fuel system

- Fill fuel tank with high-quality unleaded fuel until the first automatic shutoff of the fuel pump nozzle.

NOTE: During extended periods of vehicle storage (60 days or more), fuel may deteriorate due to oxidation. This can damage rubber and other polymers in the fuel system and may also clog small orifices.

Ford Gas Stabilizer should be added whenever actual or expected storage periods exceed 60 days. Follow the instructions on the label. The vehicle should then be operated at idle speed to circulate the additive throughout the fuel system.

A volatile corrosion inhibitor added to the fuel system will protect the fuel system's inner surfaces from corrosion. Follow the instructions packaged with the product.

Cooling system

- Protect against freezing temperatures.

Battery

- Check and recharge as necessary.
- Keep connections clean and covered with a light coat of grease.
- If storing your vehicle for more than 30 days without recharging the battery, it may be advisable to disconnect the battery cables to ensure battery charge is maintained for quick starting.

Servicing Your Contour

Brakes

- Make sure brakes and parking brake are fully released.

Tires

- Maintain recommended air pressure.

Miscellaneous

- Make sure all linkages, cables, levers and clevis pins under vehicle are covered with grease to prevent rust.
- Move vehicles at least 25 feet (10 m) every 15 days to lubricate working parts to prevent corrosion.

**YOU FOUND
THE RIGHT PLACE.**



**Quality Care is more
than automotive service.**

**It's our goal to make you so
happy with your vehicle
and our service, you'll want
to come back. For service.
And your next vehicle.**

**Quality Care.
It's at your dealer.**

 **FORD**
QUALITY CARE



© 1995 Ford Motor Company

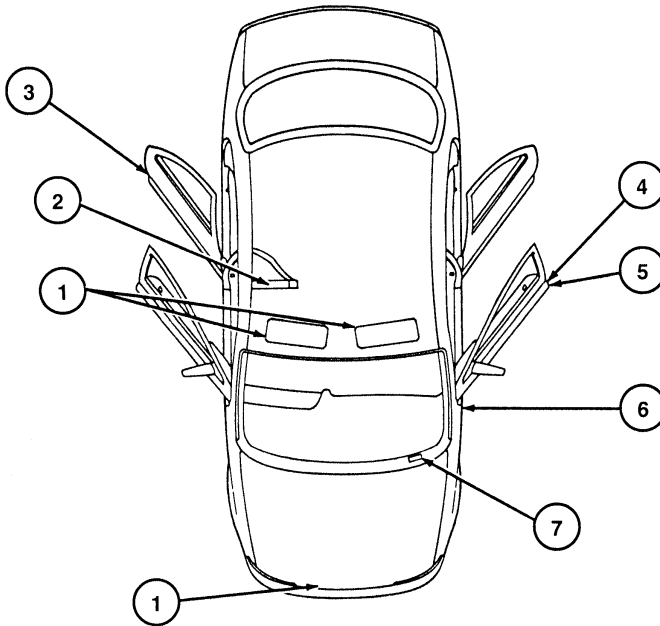

No.	Description	Refer to this label for information regarding
1	Air Bag Warning Labels	Air bag precautions
2	Child Seat Label	Child seat installation precautions
3	Childproof Lock Label	Childproof lock operation
4	Tire Pressure Decal	Wheel and tire information
5	Safety Compliance Certification Label	Name and date of manufacturer, GVWR*, GAWR**
6	Fuel Pump Shut-Off Label (In driver's footwell)	Fuel pump shut-off location
7	Vehicle Identification Number (VIN) label	Servicing or warranty information specific to your vehicle

* Gross Vehicle Weight Rating ** Gross Axle Weight Rating

Warning label locations

Front Exterior View

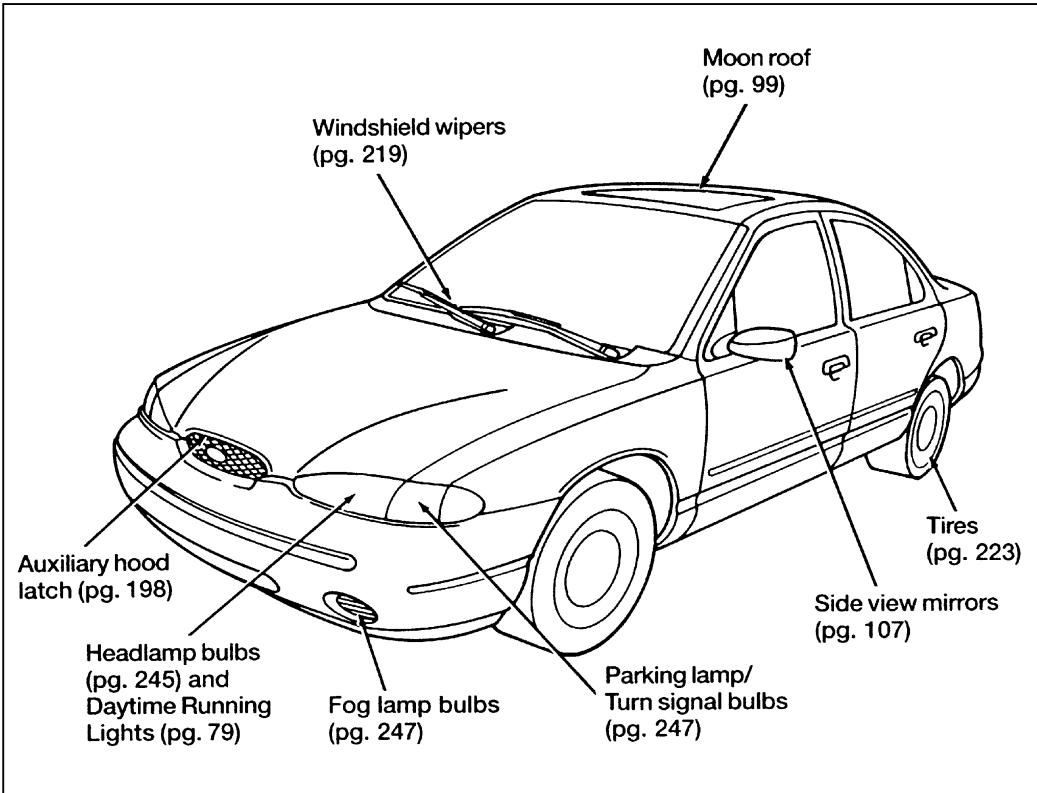

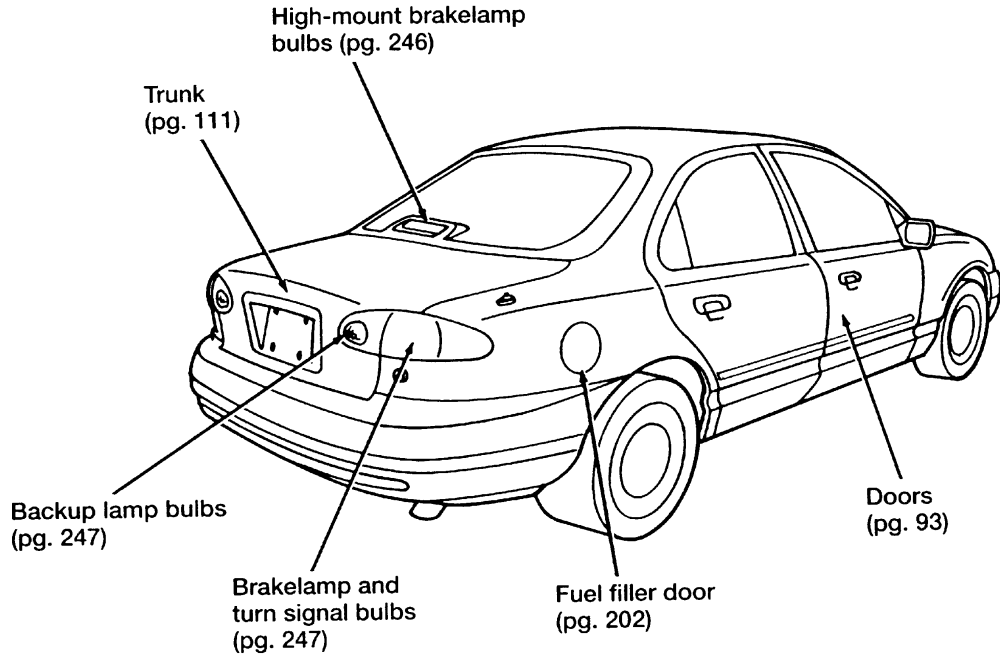

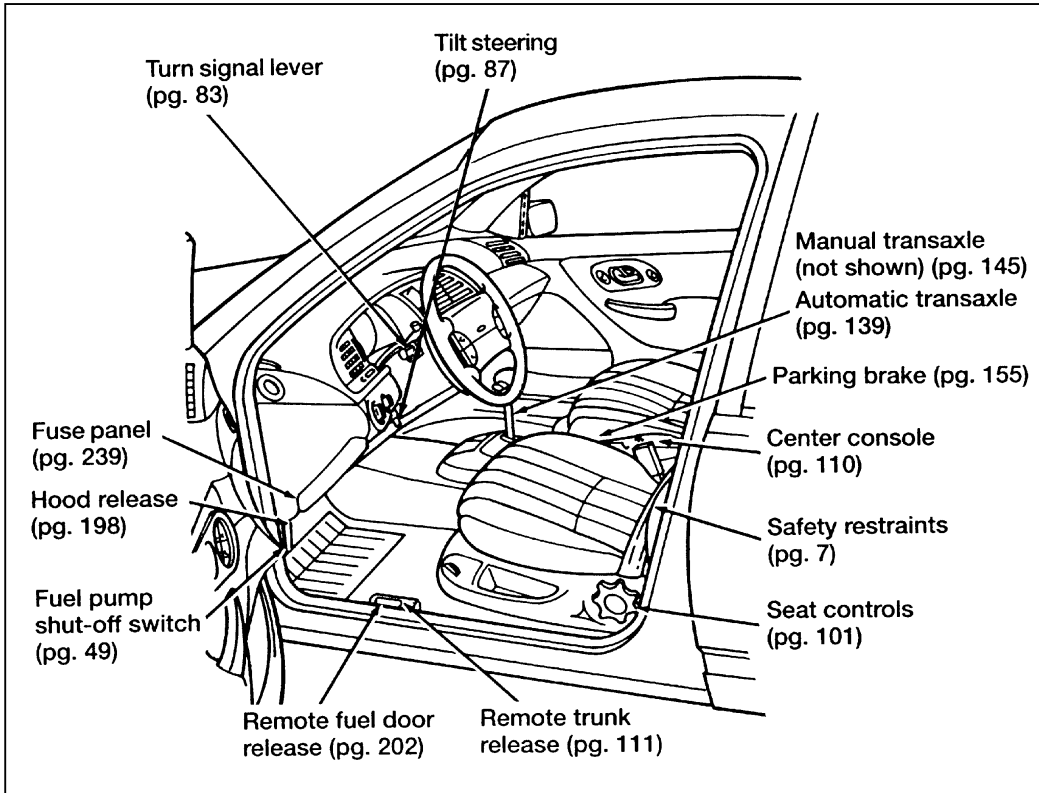

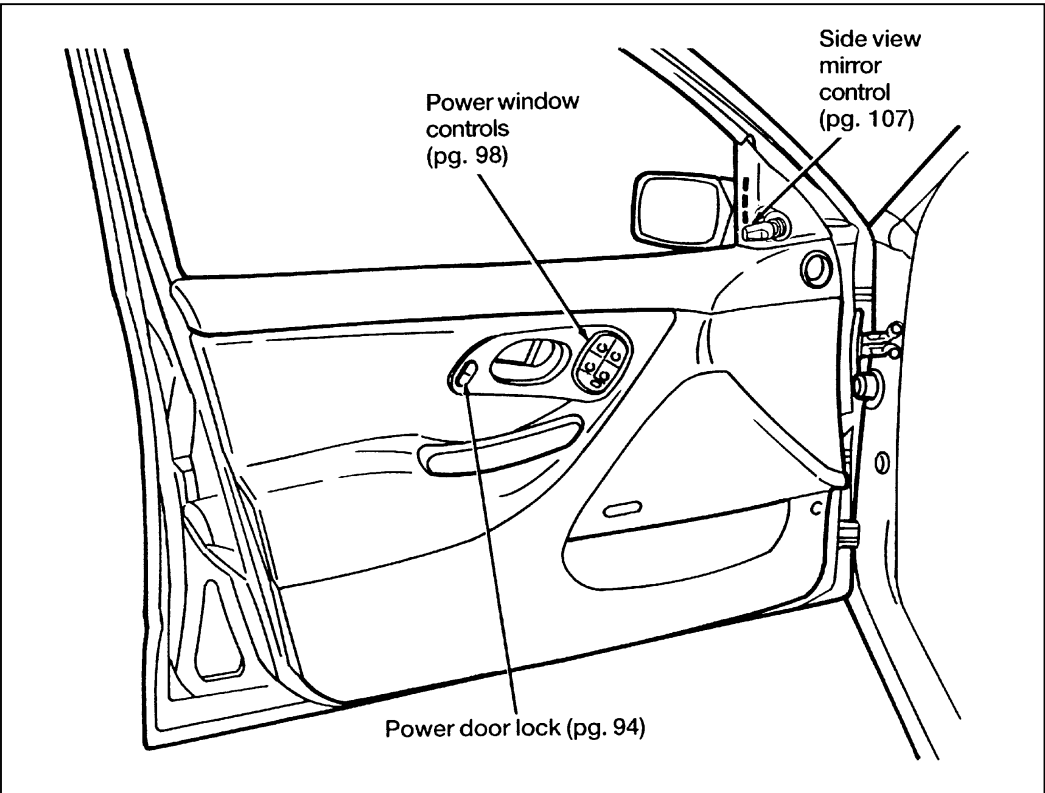

Driver's Door

Instrument Panel

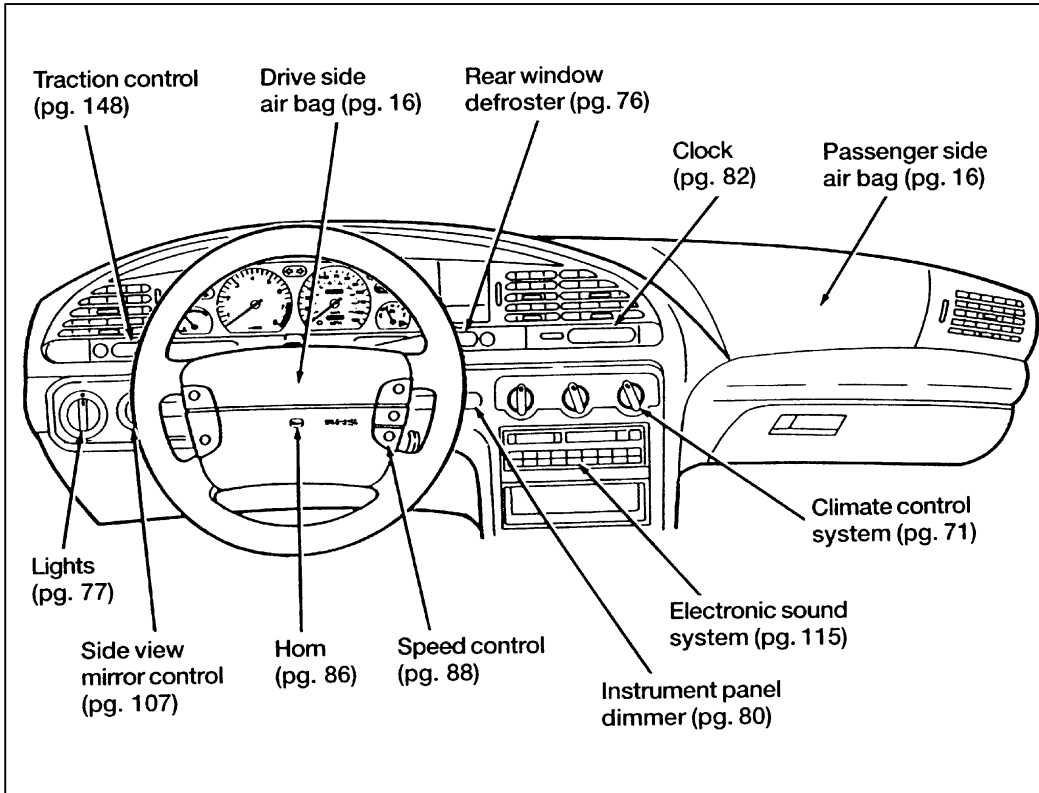

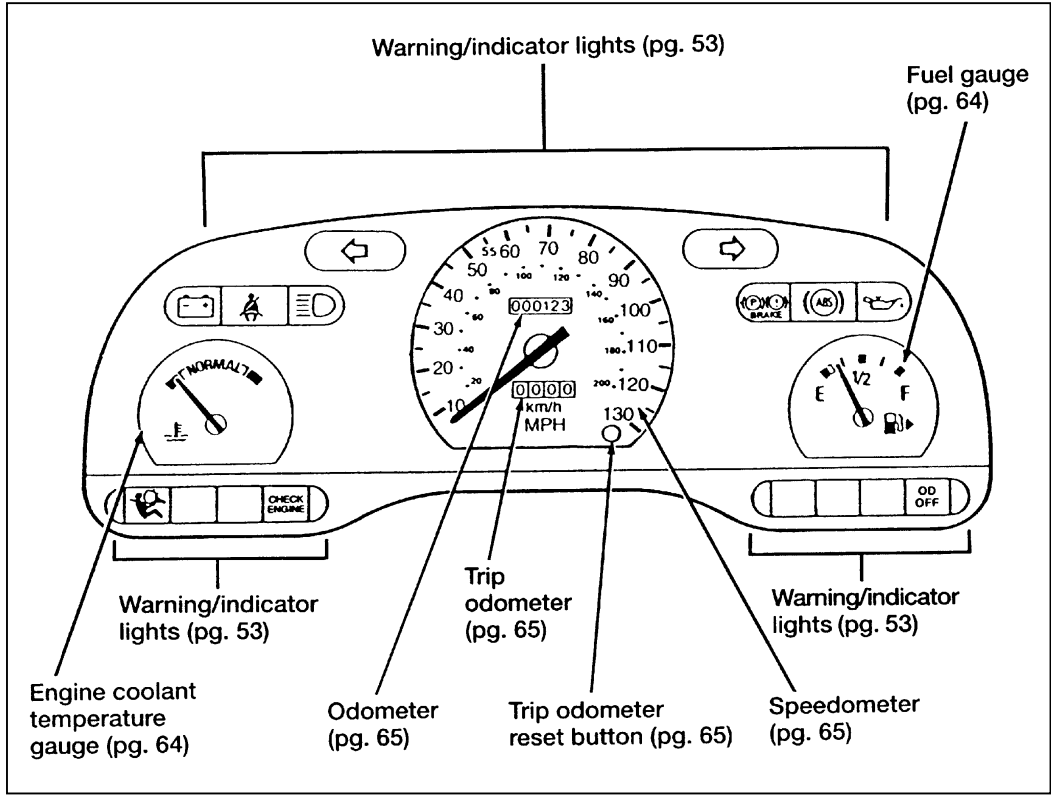

Q U - C K - I N D E X

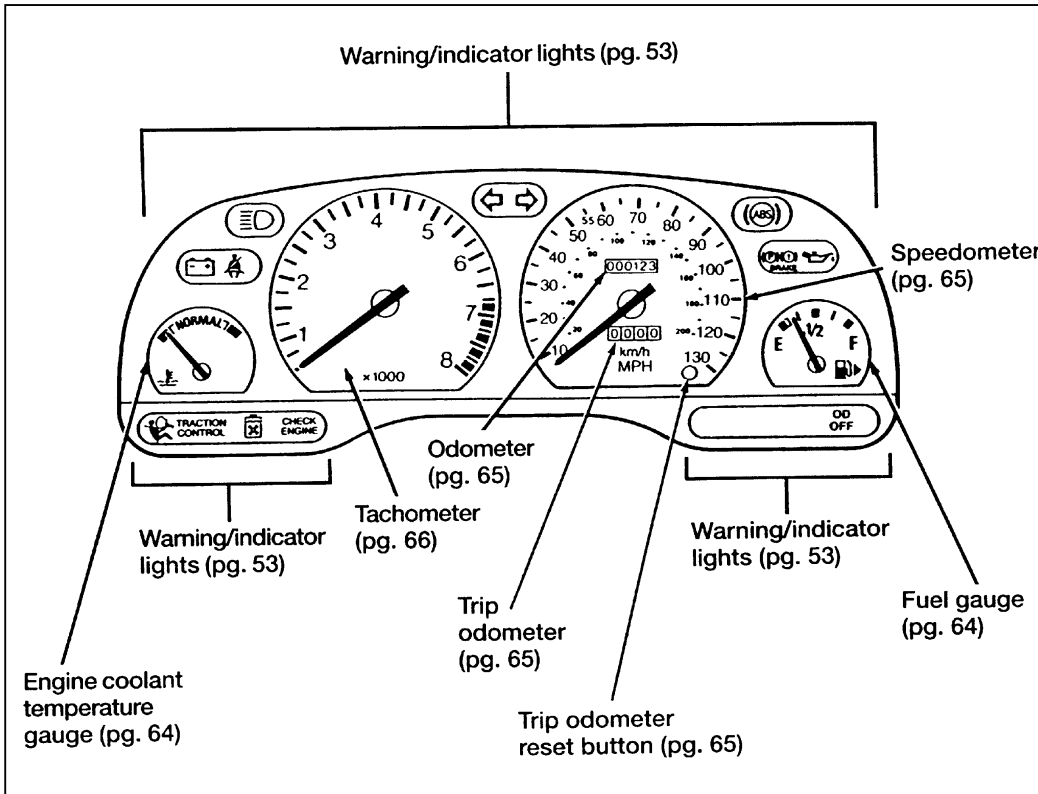

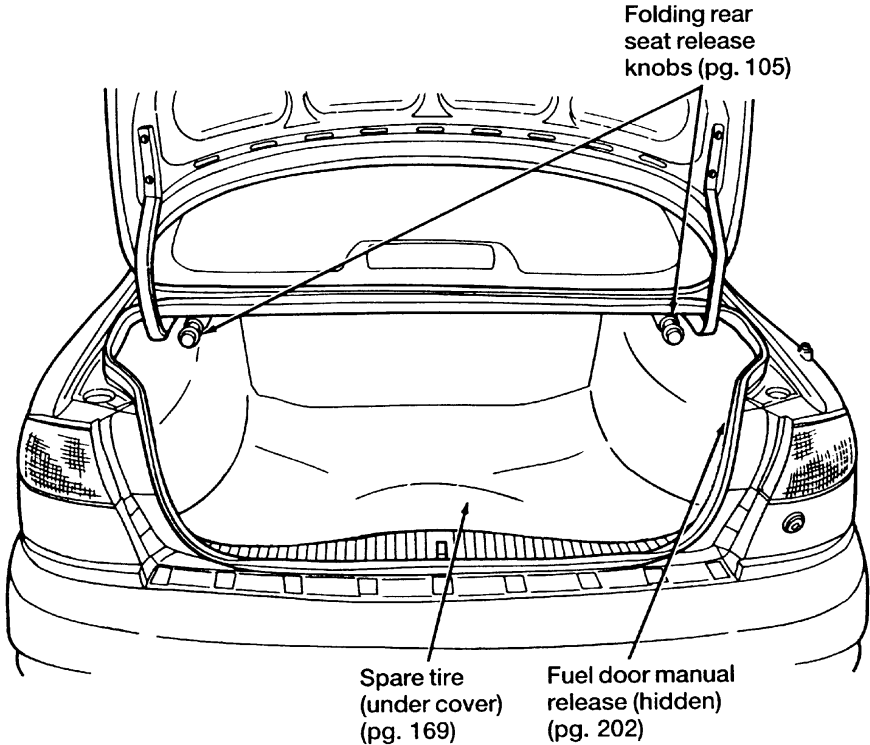

The 2.0L Engine Compartment

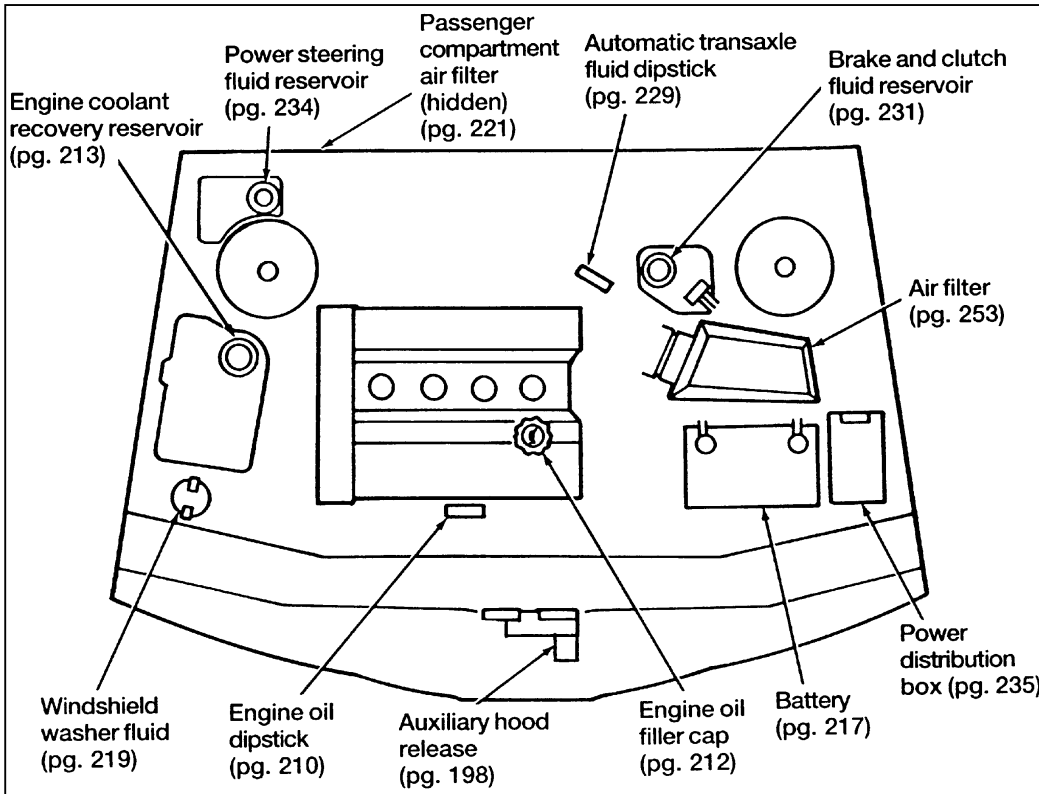

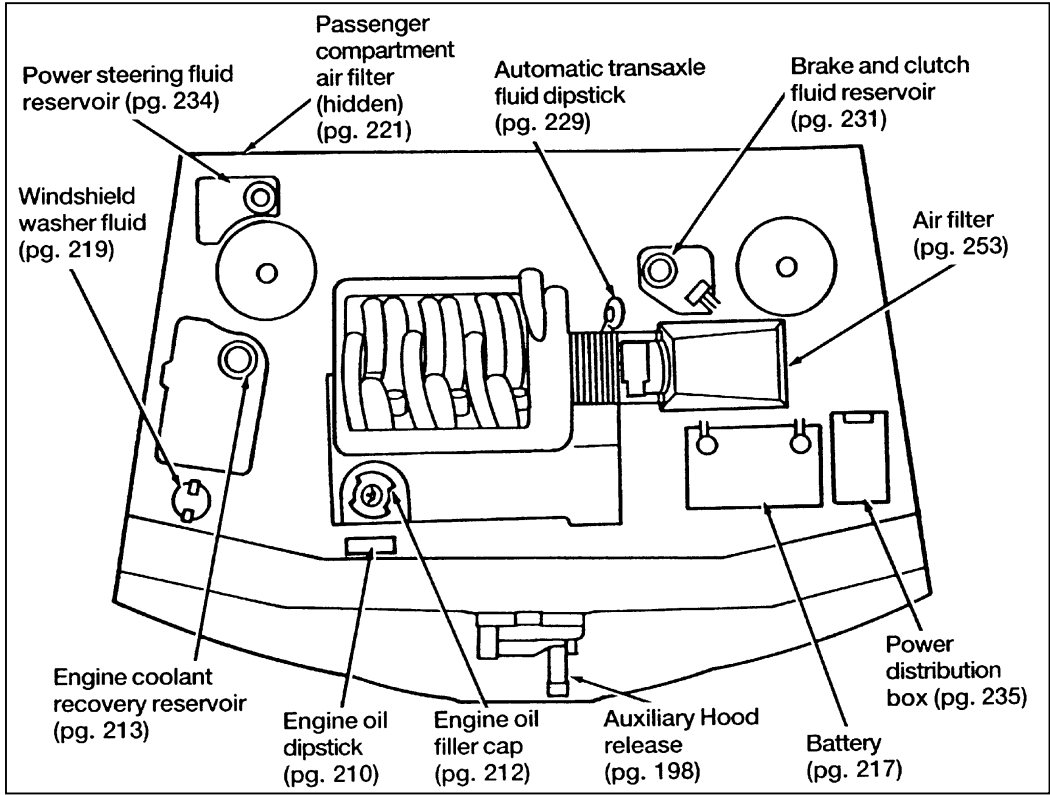

INDEX

INDEX

A

ABS warning light (see Anti-lock brake system)	66
Additives, engine oil.	210
Air bag supplemental restraint system	
and child safety seats	18, 26
description	16
disposal	24
driver air bag.	16
indicator light.	60
operation.	20
passenger air bag	19
proper seating	17
tone generator	24
wearing safety belts	17
Air cleaner filter	
location	199
specifications	253
Alarm, activating remote personal.	96
Antenna, radio (see Electronic sound system).	136
Antifreeze (see Engine coolant)	213
Anti-lock brake system (ABS), warning light	66
Anti-theft lug nuts and key.	174
Appeals (see Dispute settlement board)	182
Assistance (see Customer assistance).	179
Audio system (see Electronic sound system)	115
Automatic transaxle	
driving with	139
fluid, adding	231
fluid, checking	229
fluid, refill capacities	252
fluid, specification.	254

Axle	
lubricant specifications	254
refill capacities	252

B

Backing up	142, 146
Basic vehicle warranty	3
Battery	
acid, treating emergencies	163, 218
charging system warning light	58
disconnecting	167
how to service	217
jumping a disabled battery	163
maintenance-free	217
proper disposal, recycling	218
replacement, specifications	253
when storing your vehicle	256
Brake fluid	
brake warning light	57
checking and adding	232
description	232
specifications	254
Brakelamp, high-mount brakelamp	246
Brakes	
anti-lock brake system (ABS) warning light	66
applying the brakes	149
brake warning light	57
fluid, checking and adding	232
fluid, refill capacities	252
fluid, specifications	254
master cylinder	232
new brake linings	4
noise	150
parking	152
trailer	160
when storing your vehicle	257

Brake-shift interlock	140
Break-in period	4
Brights (high beams)	59, 84
Bulbs, replacing	
halogen	245
headlamps	245
high-mount brakelamp.	246

C

Canada, customer assistance	186
Canada, warranty information	3
Canadian Motor Vehicle Arbitration Plan (CAMVAP)	187
Capacities for refilling fluids	252
Carbon monoxide in exhaust	51
Car seats for children (see Child safety seats)	26
Cassette tape player (see Electronic sound system)	134
Catalytic converter	248
Chains, tires.	228
Changing a tire	168
Charging system warning light	58
Childproof locks.	93
Child safety restraints	
child safety belts	38
child safety seats	26
Child safety seats	
and air bags	18, 26
attaching with tether straps	37
automatic locking mode (retractor)	26
in front seat	29
in rear outboard seat	29
tether anchorage hardware	37
Chime	
headlamps on.	60
key in ignition	43
safety belt	56

Circuit breakers, checking and replacing	243
Cleaning your vehicle	
CD player and discs	125
chrome and aluminum parts	6
exterior	5
exterior lamps	79
fabric	106
headlamps	79
instrument panel	69
mirrors.	108
plastic parts	6
polishing	5
rear windows.	76
rustproofing	6
safety belts	16
tail lamps	79
upholstery and interior trim	106
washing	5
wheels	229
windows.	76
Clutch	
operation while driving	145
shifting the gears	145
specifications	254
Cold engine starting	46
Combination lap and shoulder belts.	9
Compact disc player (see Electronic sound system)	121
Compact disc radio (see Electronic sound system)	116
Console, description	110
Controls	
instrument panel	69
mirrors.	107
steering column.	83
Coolant (see Engine coolant)	
checking and adding	213
preparing for storage	256
refill capacities	252

Coolant (see Engine coolant) (continued)	
specifications	254
temperature gauge	64
Cooling fan	196
Crankcase emission filter	253
Cruise control (see Speed control)	88
Customer Assistance Centre, Ford of Canada.	186

D

Dashboard (see Instrument panel)	69
Daytime running light system	79
Defects, reporting	185
Defrost, rear window and side view mirrors	76
Dipstick	
automatic transaxle fluid.	229
engine oil	210
power steering fluid.	234
Disabled vehicle (see Towing).	175
Dispute Settlement Board.	182
Doors	93
lubricant specifications.	254
Driving under special conditions	
bad weather	153
heavy load	155
high water	155
slippery roads	153
tips for safe driving	153
towing a trailer	157

E

Electrical system	
circuit breakers	243
fuses	235, 242
relays	235
Electronic sound system	
radio reception	136
tuning the radio.	117, 131
warranty and service information.	137

Electronic stereo cassette radio (see Electronic sound system)	130
Electronic stereo radio (see Electronic sound system)	130
Emergencies, roadside	
assistance	179
battery acid spills	163
jump-starting	163
towing	175
Emergency brake (parking brake)	152
Emission control system	
catalytic converter	248
emissions warranty	3, 248
Engine	
check engine warning light	61
does not start	47
fuel injected engine, starting	43, 45
fuel pump shut-off switch	50
preparing to start	44
refill capacities	252
service points	199
starting	45
starting after a collision	50
storing your vehicle	256
Engine block heater	49
Engine coolant	
checking and adding	213
disposal	216
low coolant warning light	67
preparing for storage	256
recovery reservoir	199, 214
refill capacities	252
specifications	254
temperature gauge	64

Engine coolant temperature gauge.	64
Engine fan	196
Engine oil	
“break-in” oils	4
changing oil and oil filter	212
checking and adding	210
dipstick	210
disposal	212
engine oil pressure warning light	58
filter, specifications	253
refill capacities	252
specifications	254
synthetic oil	210
viscosity	209
Entry system, illuminated	94
Exhaust fumes.	51
Extended Service Plan, Ford	4

F

Flashers, hazard	86
Flashing the lamps.	84
Flat tire.	168
Fluid refill capacities.	252
Foglamps	78
Ford Dispute Settlement Board	182
Ford Extended Service Plan.	4
Ford of Canada Customer Assistance Centre	186
Foreign registration	187
French owner guides, how to obtain.	3
Fuel	
calculating fuel economy.	207
capacity	252
choosing the right fuel.	204
comparisons with EPA fuel economy estimates.	208
filling your vehicle with fuel	202
filter, specifications	253
fuel gauge	64
running out of fuel	207

Fuel (continued)	
safety information relating to automotive fuels.	206
storing your vehicle.	256
treating emergencies.	206
Fuel cap	
removing.	202
replacing.	204
Fuel filler door, remote release	202
Fuel filter, specifications	253
Fuel gauge	64
Fuel pump shut-off switch	
engine does not start	50
starting after a collision	50
Fuse panels, instrument panel	242
Fuses	
charts	242
checking and replacing	242
circuit breakers	243

G

Gas cap (see Fuel cap)	202
Gas mileage (see Fuel economy)	207
Gasoline (see Fuel)	202
Gauges, Mechanical	
engine coolant temperature gauge	64
fuel gauge	64
odometer.	65
speedometer	65
tachometer	66
trip odometer.	65
GAWR (Gross Axle Weight Rating)	
calculating	156
definition.	155
driving with a heavy load	155
location	155

Gearshift	
automatic operation	139
locking the gearshift.	41
positions	140
shifting the gears	145
shift-lock	140
GVWR (Gross Vehicle Weight Rating)	
calculating	156
definition.	155
driving with a heavy load	155
location	155

H

Hazard flashers	86
Headlamps	
aiming	244
checking alignment	244
cleaning	79
daytime running lights.	79
flashing	84
high beam	84
replacing bulbs	245
turning on and off	77
warning chime	60
Head restraints	101
High beams	
indicator light.	59
operation.	84
High-mount brakelamp	
description	246
replacing the bulb.	246
Hitch.	159
Hood	
latch location	198
lubrication specifications	254
release lever	198
working under the hood.	196
Horn	86

I

Identification Number, Vehicle (VIN)	181, 186
Idle	
relearning	167
speed	48
Ignition	
chime	43
positions of the ignition	41
removing the key	42
Infant seats (see Safety seats)	26
Instrument cluster	53
Instrument panel	
lighting up panel and interior	80
location of components	69

J

Jack, operation	171
Jump-starting your vehicle	
attaching cables	164
disconnecting cables	167

K

Keys	
key in ignition chime	43
positions of the ignition	41
removing from the ignition	42
stuck in lock position	41

L

Lamps	
checking	244
daytime running light system	79
dome lamps	80
flashing the lamps	84
fog lamps	78
hazard flashers	86
headlamps	77
high beams	84

Lamps (continued)	
high-mount brakelamp	246
illuminated entry system	94
instrument panel, dimming	80
interior lamps	80
replacing bulbs	245
trailer	160
Lane change indicator (see Turn signal)	83
Lap belts	13
Lights, warning and indicator	
air bag	60
anti-lock brakes (ABS)	66
brake	57
charging system	58
check engine	61
engine oil pressure	58
high beam	59
low coolant	67
oil pressure	58
safety belt	56
turn signal indicator	63, 83
Load limits	
GAWR	155
GVWR	155
trailer towing	157
Lubricant specifications	254
Luggage compartment	111
Lug nuts	
anti-theft	174
standard	171

M	
Maintenance (see Servicing)	195
Manual transaxle	
backing up (reverse).	146
clutch	145
shifting gears	145
Map pockets	111
Master cylinder, brakes	232
Mileage, calculating fuel economy.	207
Mirrors	
side view mirrors (manual)	107
Moon roof	99
Motorcraft parts.	253
N	
National Highway Traffic Safety Administration	185
New vehicle break-in	4
O	
Odometer	
trip odometer.	65
Oil filter	253
Oil (see Engine oil)	209
Oil viscosity	209
On-board diagnostic (OBD II) system	250
Overseas offices	187
P	
Panic alarm feature, remote entry system	96
Parking brake	
operation.	152
warning light.	57
Parts (see Motorcraft Parts).	253
PCV valve, specifications.	253
Power door locks	94
Power features	
door locks	94
mirrors.	107

Power features (continued)	
moon roof	99
seats	104
windows	98
Power steering	
dipstick	234
driving with power steering	149
fluid, checking and adding	234
fluid, refill capacity	252
fluid, specifications	254
servicing	149
Prop rod, hood	198

R

Radio (see Electronic sound systems)	115
Rear axle, refill capacity	252
Rear window	98
Refill capacities for fluids.	252
Remote entry system	
locking/unlocking doors	95
opening the trunk	95
panic alarm.	96
replacement/additional transmitters.	97
replacing the batteries	96
Reporting safety defects	185
Restraints, safety (see Safety restraints)	
adult.	7
child	25
head	101
infant	25
Roadside assistance	179
Roadside emergencies	163
Rotating the tires	224

S

Safe driving tips	153
Safety belts (see Safety restraints)	7
Safety chains, when towing a trailer.	159
Safety Compliance Certification Label	155
Safety defects, reporting	185
Safety information relating to automotive fuels.	206
Safety restraints	
adjusting the safety belts	12, 14
cleaning the safety belts	16
dual locking mode retractors.	11
extension assembly	14
for adults	7
for children.	25
for infants	25
head	101
lap and shoulder belts.	9
lap belt	13
maintenance	15
proper use	7
replacement	15
warning light and chime.	56
Safety seats for children	
and air bags	18, 26
attaching with tether straps	37
in front seat	26
in rear outboard	29
in rear seat.	37
tether anchorage hardware.	37
Seat belts (see Safety restraints).	7
Seats	
adjusting the seat, manual	102
adjusting the seats, power	104
child safety seats	26
head restraints	101
Serial number (VIN)	181, 186
Service concerns.	180

Servicing your vehicle	
precautions when servicing.	196
servicing when you tow	161
Shift-lock system	140
Shift positions (see Gearshift)	140, 145
Shoulder and lap belts (see Safety restraints)	9
Side mirrors, adjusting	107
Sliding moon roof (see Moon roof)	99
Snow tires and chains	228
Spare tire	
changing the tire	168
finding the spare	169
removing the spare tire	169
temporary spare.	168
Spark plugs, specifications	253
Special driving conditions	153
Specification chart, lubricants	254
Speed control	
accelerating.	90
canceling a set speed	91
resetting	90
resuming a set speed	91
tap up/tap down	90
turning off	91
when towing a trailer	161
Speedometer	65
Starting your vehicle	
preparing to start your vehicle	44
starting a cold engine	46
starting after a collision	50
starting a warm engine	47
starting your vehicle if the battery is disabled	163
Steering, power	149
Steering wheel	
horn	86
locking.	41
speed controls	88

Storage compartments	
center console	110
map pockets	111
Storing your vehicle	255
Sunroof (moon roof)	99
Sun visor	109
Supplemental air bag readiness light	60
Supplemental Restraint System (SRS)	16

T

Tachometer	66
Tail lamps, cleaning	79
Temperature control (see Climate control)	71
Tether anchor installation (see Child restraints)	37
Tires	
changing	168
checking the pressure	223
cleaning	229
replacing	225
rotating	224
snow tires and chains	228
spare tire	169
storing your vehicle	257
tire grades	226
treadwear	226
wear bands	225
Towing a trailer (see Trailer towing)	157
Towing your vehicle	175
with a tow truck	175

Trailer towing	157
calculating maximum trailer weight	157
safety chains	159
tips	160
trailer brakes	160
trailer lamps	160
Transaxle	
automatic operation	139
fluid, checking and adding (automatic)	229
fluid, refill capacities	252
lubricant specifications	254
Transaxle control switch	142
Trip odometer	65
Trunk, using the remote entry system to open	95
Tune-up specifications (VECI)	249
Turn signal	
indicator lights	63
lever	83

U	
Used engine oil, disposal	212
V	
Variable interval wipers	84
VECI (Vehicle Emission Control Information) decal	249
Vehicle Identification Number (VIN)	181, 186
Vehicle loading	
automatic transaxles	156
calculating the load	156
manual transaxles	156
Vehicle storage	255
Ventilating your vehicle (see Climate control)	71
Viscosity (see Engine oil)	209
Visor (see Sun visor)	109
W	
Warm engine, starting	47
Warning chimes	
headlamps on	60
key in ignition	43
safety belt	56
Warning lights (see Lights)	53
Warranties	
basic	3
Canada	3
radio	137
Warranty Information Booklet	3
Washer fluid	
reservoir	219
windshield	219
Weight limits (GAWR, GVWR)	155
Wheel dollies (see Towing)	175

Wheels	
anti-theft lugnuts	174
cleaning	229
covers	171
inspection and maintenance	223
lug nuts	170
Windows	98
power windows, operating	98
Windshield washer fluid and wipers	
checking and adding fluid	219
checking and replacing wiper blades	221
operation	84
reservoir	219
specifications	220
variable interval wipers	84
Wrecker towing	175

Service Station Information

Engine Size and Type	2.0 Liter	16V (4 valves per cylinder) Electronic Fuel Injection (EFI), 4 cylinder, 121 cubic inch displacement (CID)
	2.5 Liter	24V (4 valves per cylinder) Electronic Fuel Injection (EFI), 6 cylinder, 153 cubic inch displacement (CID)
Fuel		UNLEADED FUEL ONLY — Octane 87
Fuel Tank Capacity		14.5 gallons (55.0 liters)
Engine Oil		Use only engine oil displaying the American Petroleum Institute Certification Mark — SAE 5W-30 preferred
Engine Oil Capacity	2.0 Liter	4.5 quarts (4.25 liters) (with filter change)
	2.5 Liter	5.5 quarts (5.2 liters) (with filter change)
Engine Coolant Capacity	2.0 Liter	Automatic Overdrive — 7.5 quarts (7.1 liters) 5-speed Manual — 7.0 quarts (6.6 liters)
	2.5 Liter	Automatic Overdrive — 9.1 quarts (8.6 liters) 5-speed Manual — 8.9 quarts (8.4 liters)
Tire Size and Pressure		Tire size and pressure can be found on the tire pressure decal on the left front door facing.
Brake Fluid		Use only brake fluid that meets Ford Specification ESA-M6C25-A
Power Steering Fluid		Use only power steering fluid that meets Ford Specification ESW-M2C33-F
Automatic and Manual Transaxle Fluid		Use Motorcraft MERCON® ATF or equivalent
Hood Release		Pull handle on driver's side left-hand kick panel