



# G-Class

Owner's Manual



**Mercedes-Benz**

Nur für internen Gebrauch / For internal use only

## Symbols

In this Owner's Manual, you will find the following symbols:

### **WARNING**

Warning notices draw your attention to hazards that may endanger your health or life, or the health or life of others.

### **Environmental note**

Environmental notes provide you with information on environmentally aware actions or disposal.

 Notes on material damage alert you to dangers that could lead to damage to your vehicle.

 This symbol indicates useful instructions or further information that could be helpful to you.

▶ This symbol designates an instruction you must follow.

▶ Several consecutive symbols indicate an instruction with several steps.

(▷ page) This symbol tells you where you can find further information on a topic.

▷▷ This symbol indicates a warning or an instruction that is continued on the next page.

**Display** This text indicates a message on the multifunction/COMAND display.



This symbol tells you that you will find the information in the Digital Owner's Manual.

Parts of the software in the vehicle are protected by copyright © 2005  
The FreeType Project  
<http://www.freetype.org>. All rights reserved.

## Welcome to the world of Mercedes-Benz

Before you first drive off, read this Owner's Manual carefully and familiarise yourself with your vehicle. For your own safety and a longer vehicle life, follow the instructions and warning notices in this manual. Disregarding them may lead to damage to the vehicle or personal injury.

The equipment or model designation of your vehicle may vary according to:

- model
- order
- country variant
- availability

The illustrations in this manual show a left-hand-drive vehicle. On right-hand-drive vehicles, the layout of components and controls differs accordingly.

Mercedes-Benz is constantly updating its vehicles to the state of the art.

Mercedes-Benz therefore reserves the right to introduce changes in the following areas:

- design
- equipment
- technical features

The equipment in your vehicle may therefore differ from that shown in the descriptions and illustrations.

The following are integral components of the vehicle:

- Owner's Manual
- Service Booklet
- equipment-dependent supplements

Keep printed copies of the documents in the vehicle at all times. If you sell the vehicle, always pass the documents on to the new owner.

**i** You can get to know the important features of your vehicle in the interactive Owner's Manual on the Internet at:

**<http://www.mercedes-benz.de/betriebsanleitung>**

The technical documentation team at Daimler AG wishes you safe and pleasant motoring.



<b>Index</b> .....	<b>4</b>	<b>At a glance</b> .....	<b>25</b>
<b>Introduction</b> .....	<b>20</b>	<b>Safety</b> .....	<b>37</b>
		<b>Opening and closing</b> .....	<b>67</b>
		<b>Seats, steering wheel and mirrors</b> ....	<b>89</b>
		<b>Lights and windscreen wipers</b> .....	<b>103</b>
		<b>Climate control</b> .....	<b>123</b>
		<b>Driving and parking</b> .....	<b>141</b>
		<b>On-board computer and displays</b> ....	<b>209</b>
		<b>Stowing and features</b> .....	<b>265</b>
		<b>Maintenance and care</b> .....	<b>285</b>
		<b>Breakdown assistance</b> .....	<b>299</b>
		<b>Wheels and tyres</b> .....	<b>317</b>
		<b>Technical data</b> .....	<b>333</b>

- 1, 2, 3 ...**
- 12 V socket** ..... 278
- 4ETS (Electronic Traction System)**  
Function/notes ..... 62
- 4MATIC (permanent four-wheel drive)** ..... 197
- 4MATIC off-road system** ..... 197
- A**
- ABS (Anti-lock Braking System)**  
Display message ..... 229  
Function/notes ..... 60  
Important safety notes ..... 60  
Warning lamp ..... 254
- Activating/deactivating air-recirculation mode** ..... 133
- Active Blind Spot Assist**  
Activating/deactivating (on-board computer) ..... 220  
Display message ..... 243  
Function/notes ..... 193  
Towing a trailer ..... 196
- ADAPTIVE BRAKE** ..... 64
- Adaptive brake lamps** ..... 61
- AdBlue®**  
Display message ..... 240  
Notes ..... 341  
topping up ..... 160
- Additives (engine oil)** ..... 342
- Airbags**  
Front airbag (driver, front passenger) ..... 41  
Important safety guidelines ..... 40  
PASSENGER AIRBAG OFF warning lamp ..... 50  
Triggering ..... 39  
Windowbag ..... 42
- Air conditioning**  
Windscreen heating ..... 132
- Air-conditioning system**  
see Climate control
- Air filter (white display message)** .... 240
- Air vents**  
Important safety notes ..... 139  
Rear ..... 140  
Setting ..... 139  
Setting the centre air vents ..... 139  
Setting the side air vents ..... 139
- Alarm system**  
see ATA (Anti-Theft Alarm system)
- All-wheel drive**  
Transfer case ..... 201
- AMG menu (on-board computer)** ..... 225
- Anti-lock Braking System**  
see ABS (Anti-lock Braking System)
- Anti-Theft Alarm system**  
see ATA (Anti-Theft Alarm system)
- Approach/departure angle** ..... 172
- Aquaplaning** ..... 167
- Ashtray** ..... 277
- Assistance menu (on-board computer)** ..... 220
- ASSYST service interval display**  
Service messages ..... 290, 291
- ATA (Anti-Theft Alarm system)**  
Activating/deactivating ..... 64  
Function ..... 64  
Interior motion sensor ..... 65  
Switching off the alarm ..... 64  
Tow-away protection ..... 65
- AUTO lights**  
Display message ..... 236  
see Lights
- Automatic car wash** ..... 292
- Automatic engine start (ECO start/stop function)** ..... 147
- Automatic engine switch-off (ECO start/stop function)** ..... 146
- Automatic headlamp mode** ..... 105
- Automatic transmission**  
Automatic drive program ..... 153  
Display message ..... 248  
Drive position (ECO start/stop function) ..... 151  
Driving tips ..... 152  
Emergency running mode ..... 156  
Engaging drive position ..... 151  
Engaging neutral ..... 150  
Engaging reverse gear ..... 150  
Engaging the park position ..... 150  
Important safety notes ..... 149  
Kickdown ..... 152  
Manual drive program ..... 154

Neutral (ECO start/stop function) .	150	<b>Belt tensioner</b>	
Overview .....	149	Activation .....	39
Problem (fault) .....	156	Function .....	47
Program selector button .....	152	<b>Blind Spot Assist</b>	
Pulling away .....	144	Activating/deactivating .....	220
Selector lever .....	149	Display message .....	243
Shift ranges .....	153	Notes/function .....	190
Steering wheel gearshift paddles ...	153	Trailer towing .....	192
Trailer towing .....	152	see Active Blind Spot Assist	
Transmission position display .....	150	<b>BlueTEC (AdBlue®)</b> .....	341
<b>Automatic transmission emer-</b>		<b>Bonnet</b>	
<b>gency running mode</b> .....	156	Closing .....	287
<b>Auxiliary heating</b>		Display message .....	249
Activating/deactivating .....	134	Important safety notes .....	286
Activating/deactivating (on the		Opening .....	287
centre console) .....	135	<b>Brake fluid</b>	
Display message .....	250	Display message .....	232
Important safety notes .....	134	Notes .....	342
Malfunction .....	138	<b>Brake lamps</b>	
Problem (display message) .....	138	Adaptive .....	61
Remote control .....	135	Display message .....	235
Setting .....	223	<b>Brakes</b>	
Setting the departure time .....	136	ABS .....	60
<b>Auxiliary ventilation</b>		BAS .....	61
Activating/deactivating .....	134	Brake fluid (notes) .....	342
Activating/deactivating (on the		Display message .....	229
centre console) .....	135	Driving tips .....	165
Problem (display message) .....	138	High-performance brake system ...	166
Remote control .....	135	Important safety notes .....	165
<b>Axle load, permissible (trailer tow-</b>		Parking brake .....	164
<b>ing)</b> .....	346	Warning lamp .....	253
		<b>Breakdown</b>	
		see Flat tyre	
		see Towing away	
		<b>Bulbs</b>	
		Brake lamp .....	118
		Cornering light function .....	117
		Foglamps .....	117
		Rear foglamp .....	118
		Reversing lamp .....	118
		Tail lamp .....	118
		see Changing bulbs	
<b>B</b>			
<b>Backrest (display message)</b> .....	249		
<b>BAS (Brake Assist System)</b> .....	61		
<b>Battery</b>			
Changing (auxiliary heating			
remote control) .....	137		
Changing (key) .....	71		
Checking (key) .....	71		
Important safety guidelines (key) ....	70		
<b>Battery (vehicle)</b>			
Charging .....	307		
Display message .....	239		
Important safety notes .....	305		
Jump starting .....	309		
Overview .....	305		

- C**
- Cabriolet**
- Draught stop ..... 84
  - Soft top ..... 81
  - Tonneau cover ..... 85
- Cabriolet soft top**
- Cleaning ..... 293
- Calling up a fault**
- see Display messages
- Care**
- Automatic car wash ..... 292
  - Cabriolet soft top ..... 293
  - Chrome parts ..... 295
  - Display ..... 296
  - Headlamps ..... 294
  - High-pressure cleaner ..... 292
  - Interior ..... 296
  - Matt paintwork ..... 293
  - Notes ..... 291
  - Paint ..... 293
  - Plastic trim ..... 296
  - Reversing camera ..... 295
  - Seat belt ..... 297
  - Seat covers ..... 296
  - Sensors ..... 294
  - Tail pipes ..... 295
  - Trailer coupling ..... 295
  - Trim strips ..... 296
  - Wheels ..... 293
  - Windows ..... 294
  - Wiper blades ..... 294
  - Wooden trim ..... 296
- CD player/CD changer(on-board computer)** ..... 218
- Central locking**
- Automatic locking (on-board computer) ..... 223
  - Locking/unlocking (key) ..... 68
- Centre console**
- Overview ..... 32
  - Upper section ..... 32
- Changing bulbs**
- Important safety notes ..... 114
  - Overview of bulb types ..... 115
  - Parking lamps (front) ..... 116
  - Reversing lamps ..... 118
  - Standing lamps ..... 116
  - Turn signals (front) ..... 117
- Changing gears** ..... 152
- Checklist**
- After driving off-road ..... 171
  - Before driving off-road ..... 170
- Child-proof locks**
- Important safety notes ..... 59
  - Rear doors ..... 59
- Children**
- In the vehicle ..... 48
  - Restraint systems ..... 48
- Child seat**
- Automatic recognition ..... 50
  - ISOFIX ..... 51
  - On the front-passenger seat ..... 49
  - Recommendations ..... 56
  - Suitable positions ..... 54
  - Top Tether ..... 52
  - Troubleshooting ..... 54
- Chrome parts (cleaning instructions)** ..... 295
- Cigarette lighter** ..... 277
- Climate control**
- Auxiliary heating/ventilation ..... 126
  - Controlling automatically ..... 130
  - Cooling with air dehumidification . . 128
  - Demisting the windows ..... 132
  - Demisting the windscreen ..... 131
  - Important safety notes ..... 124
  - Indicator lamp ..... 130
  - Notes on using THERMATIC automatic climate control ..... 125
  - Overview of systems ..... 124
  - Problems with "cooling with air dehumidification" ..... 130
  - Problem with the rear window heating ..... 133
  - Setting the air distribution ..... 131
  - Setting the airflow ..... 131
  - Setting the air vents ..... 139
  - Setting the temperature ..... 131
  - Switching air-recirculation mode on/off ..... 133
  - Switching on/off ..... 126
  - Switching residual heat on/off ..... 133
  - Switching the rear window heating on/off ..... 133

- Switching the ZONE function on/off ..... 131
  - THERMATIC automatic climate control (2-zone) ..... 125
  - Cockpit**
    - Overview ..... 26
    - see Instrument cluster
  - COMAND**
    - see Separate operating instructions
  - Combination switch** ..... 108
  - Constant headlamp mode**
    - see Daytime driving lights
  - Consumption statistics (on-board computer)** ..... 215
  - Convenience opening feature**
    - see Side windows
  - Coolant (engine)**
    - Checking the level ..... 289
    - Display message ..... 237
    - Notes ..... 343
    - Temperature (on-board computer) . 225
    - Temperature gauge ..... 212
    - Warning lamp ..... 260
  - Cooling**
    - see Climate control
  - Cornering light function**
    - Function/notes ..... 110
  - Courtesy lights** ..... 114
  - Cruise control**
    - Cruise control lever ..... 174
    - Display message ..... 245
    - Driving system ..... 173
    - Selecting ..... 175
  - Cup holder**
    - Centre console ..... 275
    - Important safety notes ..... 275
    - Rear compartment ..... 275
- D**
- Data**
    - see Technical data
  - Daytime driving lights**
    - Display message ..... 236
    - Switching on/off (on-board computer) ..... 222
    - Switching on/off (switch) ..... 105
  - Delayed switch-off**
    - Exterior lighting (on-board computer) ..... 222
    - Interior lighting ..... 222
  - Diagnostics connection** ..... 22
  - Diesel** ..... 339
  - Diesel particle filter** ..... 164
  - Differential locks** ..... 204
  - Digital speedometer** ..... 216
  - Dipped-beam headlamp**
    - Switching on/off ..... 105
  - Dipped-beam headlamps**
    - Display message ..... 234
    - Setting for driving abroad (symmetrical) ..... 104
  - Display (cleaning instructions)** ..... 296
  - Display message**
    - ASSYST service interval display ..... 290
    - General information ..... 228
    - Hiding (on-board computer) ..... 228
  - Display messages**
    - Calling up (on-board computer) ..... 228
    - Driving systems ..... 241
    - Engine ..... 237
    - Key ..... 251
    - Lights ..... 234
    - Safety systems ..... 229
    - Tyres ..... 245
    - Vehicle ..... 248
  - Distance display (on-board computer)** ..... 220
  - Distance warning signal (warning lamp)** ..... 262
  - DISTRONIC PLUS**
    - Activating ..... 184
    - Activation conditions ..... 184
    - Cruise control lever ..... 183
    - Deactivating ..... 188
    - Display message ..... 243
    - Displays in the multifunction display ..... 187
    - Driving tips ..... 189
    - Function/notes ..... 182
    - Important safety notes ..... 182
    - Selecting ..... 183
    - Setting the specified minimum distance ..... 188
    - Warning lamp ..... 262

- Door**
- Automatic locking (on-board computer) ..... 223
  - Automatic locking (switch) ..... 74
  - Central locking/unlocking (key) ..... 68
  - Display message ..... 249
  - Emergency locking ..... 75
  - Emergency unlocking ..... 74
  - Important safety notes ..... 73
  - Opening (from the inside) ..... 73
- Door control panel**
- Overview ..... 35
- Doors**
- Overview ..... 73
- Draught stop** ..... 84
- Drive program**
- Automatic ..... 153
  - Display ..... 150
  - Manual ..... 154
- Driver's seat**
- Display message ..... 249
- Drive system**
- Active Blind Spot Assist ..... 192
- Driving abroad**
- Symmetrical dipped beam ..... 104
- Driving in mountainous terrain**
- Approach/departure angle ..... 172
  - Driving downhill ..... 173
  - Gradient-climbing capability (maximum) ..... 173
- Driving off-road**
- see Off-road driving
- Driving on flooded roads** ..... 167
- Driving safety system**
- Electronic Brake-force Distribution ..... 64
  - ESP® (Electronic Stability Program) ..... 62
  - Important safety guidelines ..... 60
- Driving safety systems**
- 4ETS (Electronic Traction System) ... 62
  - ABS (Anti-lock Braking System) ..... 60
  - ADAPTIVE BRAKE ..... 64
  - Adaptive brake lamps ..... 61
  - BAS (Brake Assist System) ..... 61
  - Overview ..... 60
- Driving system**
- Variable SPEEDTRONIC ..... 178
- Driving systems**
- Blind Spot Assist ..... 190
  - Cruise control ..... 173
  - Display message ..... 241
  - DISTRONIC Plus ..... 182
  - HOLD function ..... 196
  - PARKTRONIC ..... 197
  - Reversing camera ..... 200
  - SPEEDTRONIC ..... 178
- Driving tips**
- Aquaplaning ..... 167
  - Automatic transmission ..... 152
  - Brakes ..... 165
  - DISTRONIC PLUS ..... 189
  - Downhill gradient ..... 165
  - Driving abroad ..... 104
  - Driving in winter ..... 168
  - Driving on flooded roads ..... 167
  - Driving on sand ..... 171
  - Driving over obstacles ..... 171
  - Gravel roads ..... 171
  - Icy road surfaces ..... 168
  - Off-road driving ..... 169
  - Off-road fording ..... 167
  - Snow chains ..... 320
  - Symmetrical dipped beam ..... 104
  - Towing a trailer ..... 206
  - Travelling uphill ..... 172
  - Tyre grip ..... 166
  - Tyre ruts ..... 171
  - Wet road surface ..... 165
- DVD audio**
- Operating (on-board computer) ..... 218
- DVD video**
- Operating (on-board computer) ..... 218

## E

**EASY-ENTRY feature**

- Activating/deactivating ..... 224
- Function/notes ..... 98

**EASY-EXIT feature**

- Function/notes ..... 98
- Switching on/off ..... 224

- EBD (electronic brake force distribution)**  
 Display message ..... 231  
 Function/notes ..... 64
- ECO start/stop function**  
 Deactivating/activating ..... 146  
 General information ..... 145
- Electronic Stability Program**  
 see ESP® (Electronic Stability Program)
- Electronic Traction System**  
 see 4ETS (Electronic Traction System)
- Emergency closing**  
 Soft top ..... 82
- Emergency key element**  
 Function/notes ..... 70  
 General notes ..... 70  
 Removing ..... 70
- Emergency locking**  
 Vehicle ..... 75
- Emergency unlocking**  
 Vehicle ..... 74
- Engine**  
 Display message ..... 237  
 ECO start/stop function ..... 145  
 Engine number ..... 337  
 Jump-starting ..... 309  
 Running irregularly ..... 148  
 Starting problems ..... 148  
 Starting the engine with the key .... 144  
 Stopping ..... 163  
 Warning lamp (engine diagnostics) ..... 259
- Engine electronics**  
 Notes ..... 335  
 Problem (fault) ..... 148
- Engine oil**  
 Additives ..... 342  
 Checking the oil level ..... 287  
 Display message ..... 239  
 Filling capacity ..... 342  
 Notes about oil grades ..... 341  
 Temperature (on-board computer) . 225  
 Topping up ..... 289  
 Viscosity ..... 342
- Environmental protection**  
 Note ..... 20  
 Returning an end-of-life vehicle ..... 20
- ESP® (Electronic Stability Program)**  
 AMG menu (on-board computer) ... 226  
 Deactivating/activating ..... 63  
 Display message ..... 229  
 Function/notes ..... 62  
 Important safety guidelines ..... 62  
 Trailer stabilisation ..... 63  
 Warning lamp ..... 256
- Exhaust tail pipe (cleaning instructions)** ..... 295
- Exterior lighting**  
 see Lights
- Exterior mirrors**  
 Adjusting ..... 99  
 Anti-dazzle mode (automatic) ..... 100  
 Folding in/out (automatically) ..... 100  
 Folding in/out (electrically) ..... 99  
 Folding in when locking (on-board computer) ..... 225  
 Out of position (troubleshooting) ... 100  
 Parking position ..... 101  
 Resetting ..... 100  
 Storing settings (memory function) ..... 102

## F

- Fault message**  
 see Display messages
- Filler cap**  
 see Fuel filler flap
- Fire extinguisher** ..... 301
- First-aid kit** ..... 301
- Fitting a wheel**  
 Removing a wheel ..... 328
- Fitting wheels**  
 Fitting a wheel ..... 328  
 Raising the vehicle ..... 326  
 Securing the vehicle against rolling away ..... 326
- Flat tyre**  
 Preparing the vehicle ..... 305
- Floormat** ..... 283
- Foglamps**  
 Switching on/off ..... 106
- Folding the seat backrest (rear forwards/back)** ..... 269

- Frequencies**  
 Garage door opener ..... 283  
 Mobile phone ..... 335  
 Two-way radio ..... 335
- Front foglamp (display message) ....** 236
- Front-passenger seat**  
 Display message ..... 249
- Fuel**  
 Additives ..... 339  
 Consumption statistics ..... 215  
 Displaying the current consumption ..... 215  
 Displaying the range ..... 215  
 Fuel gauge ..... 211  
 Grade (petrol) ..... 338  
 Important safety notes ..... 337  
 Notes for AMG vehicles ..... 339  
 Premium-grade unleaded petrol .... 338  
 Problem (malfunction) ..... 159  
 Quality (diesel) ..... 339  
 Refuelling ..... 156  
 Tank content/reserve fuel ..... 338
- Fuel/water separator**  
 Service ..... 291
- Fuel filler flap**  
 Emergency release ..... 158  
 Opening/closing ..... 157
- Fuel filter (white display message) .** 240
- Fuel level**  
 Calling up the range (on-board computer) ..... 215  
 Gauge ..... 211
- Fuel reserve**  
 see Fuel
- Fuel tank**  
 Capacity ..... 338  
 Problem (malfunction) ..... 159
- Fuse allocation chart** ..... 314
- Fuse box**  
 Battery case ..... 316  
 Dashboard ..... 315  
 Front-passenger footwell ..... 315  
 Transmission tunnel ..... 315
- Fuse extractor** ..... 314
- Fuses**  
 Allocation chart ..... 314  
 Before changing ..... 314  
 Dashboard fuse box ..... 315
- Fuse allocation chart ..... 314  
 Fuse box in the front-passenger footwell ..... 315  
 Fuse box in the transmission tunnel ..... 315  
 Important safety notes ..... 314  
 In the battery case ..... 316
- G**
- Garage door opener**  
 Clearing the memory ..... 283  
 Frequencies ..... 283  
 Important safety notes ..... 280  
 Opening/closing the garage door .. 282  
 Programming the remote control ... 280
- Gear indicator (on-board computer) .....** 225
- Gearshift program**  
 SETUP (on-board computer) ..... 226
- Genuine Mercedes-Benz parts** ..... 334
- Genuine wood trim and trim strips (cleaning instructions) .....** 296
- Glove compartment** ..... 267
- Gradient-climbing capability (maximum) .....** 173
- H**
- Hazard warning lamps** ..... 109
- Headlamp**  
 Cleaning system (function) ..... 108  
 Cleaning system (notes) ..... 343
- Headlamps**  
 Cleaning ..... 294  
 Misting up ..... 110  
 Topping up the cleaning system .... 290  
 see Automatic headlamp mode
- Head restraints**  
 Adjusting ..... 92  
 Adjusting (rear) ..... 93  
 Fitting/removing (rear) ..... 93  
 Luxury ..... 92  
 Resetting (front) ..... 93
- Heating**  
 see Climate control
- High-pressure cleaners** ..... 292
- Hill start assist** ..... 145

- HOLD function**  
 Function/notes ..... 196
- I**
- Immobiliser** ..... 64
- Indicator and warning lamps**  
 Coolant ..... 260  
 DISTRONIC PLUS ..... 262  
 Engine diagnostics ..... 259
- Indicator lamps**  
 Display message ..... 235
- Instrument cluster**  
 Overview ..... 211  
 Warning and indicator lamps ..... 251
- Instrument cluster lighting** ..... 212
- Interior lighting** ..... 110  
 Automatic control system ..... 111  
 Delayed switch-off (on-board computer) ..... 222  
 Luggage compartment lighting ..... 112  
 Manual control ..... 112  
 Overview ..... 110  
 Reading lamp ..... 112  
 Rear interior lighting ..... 113
- Interior motion sensor** ..... 65
- ISOFIX child seat securing system** .... 51
- J**
- Jack**  
 Pump lever ..... 327  
 Storage location ..... 302  
 Using ..... 326
- Jump starting (engine)** ..... 309
- K**
- Key**  
 Changing the battery ..... 71  
 Checking the battery ..... 71  
 Convenience opening feature ..... 78  
 Display message ..... 251  
 Door central locking/unlocking ..... 68  
 Emergency key element ..... 70  
 Important safety notes ..... 68  
 Loss ..... 72  
 Malfunction ..... 72  
 Modifying the programming ..... 69  
 Overview ..... 68  
 Problem (malfunction) ..... 72  
 Starting the engine ..... 144
- Key positions**  
 Key ..... 143
- Kickdown**  
 Manual drive program ..... 155
- L**
- Lap time (RACETIMER)** ..... 226
- Lashing eyelets** ..... 271
- Licence plate lamp (display message)** ..... 235
- Lights**  
 Activating/deactivating the interior lighting delayed switch-off ..... 222  
 Automatic headlamp mode ..... 105  
 Cornering light function ..... 110  
 Courtesy lights ..... 114  
 Dipped-beam headlamps ..... 105  
 Driving abroad ..... 104  
 Foglamps ..... 106  
 Hazard warning lamps ..... 109  
 Headlamp flasher ..... 109  
 Light switch ..... 104  
 Main-beam headlamps ..... 109  
 Parking lamps ..... 108  
 Rear foglamp ..... 107  
 Side lamps ..... 107  
 Switching the daytime driving lights on/off (on-board computer) . 222  
 Switching the daytime driving lights on/off (switch) ..... 105  
 Switching the exterior lighting delayed switch-off on/off (on-board computer) ..... 222  
 Switching the surround lighting on/off (on-board computer) ..... 222  
 Turn signals ..... 108  
 see Changing bulbs  
 see Interior lighting
- Light sensor (display message)** ..... 236
- LIM indicator lamp**  
 Cruise control ..... 174  
 DISTRONIC PLUS ..... 183  
 Variable SPEEDTRONIC ..... 179

- Limiting the speed**  
see SPEEDTRONIC
- Limit speed**  
Variable SPEEDTRONIC ..... 178
- Loading guidelines** ..... 266
- Locking**  
Emergency locking ..... 75  
From the inside (central locking button) ..... 73  
see Central locking
- Locking (doors)**  
Automatic ..... 74
- Locking centrally**  
see Central locking
- Locking verification signal (on-board computer)** ..... 223
- LOW RANGE off-road gear** ..... 202
- Luggage compartment cover**  
Fitting/removing ..... 272  
Notes/function ..... 271  
Opening and closing ..... 272  
Overview ..... 271
- Luggage compartment enlargement**  
Important safety notes ..... 268  
Overview ..... 268
- Luggage net** ..... 268
- Lumbar support**  
Adjusting the 4-way lumbar support ..... 94
- Luxury head restraint** ..... 92
- M**
- M+S tyres** ..... 320
- Main-beam headlamps**  
Display message ..... 235  
Switching on/off ..... 109
- Matt finish (cleaning instructions)** .. 293
- Memory card (audio)** ..... 218
- Memory function** ..... 102
- Mercedes-Benz Service Centre**  
see Qualified specialist workshop
- Message memory (on-board computer)** ..... 228
- Messages**  
see Display messages
- Mirrors**  
Sun visor ..... 276  
see Exterior mirrors  
see Rear-view mirror
- Mobile phone**  
Frequencies ..... 335  
Important notes ..... 278  
Installation ..... 335  
Menu (on-board computer) ..... 218  
Notes/placing in the bracket ..... 279  
Operating (on-board computer) ..... 280  
Transmission output (maximum) .... 335
- Mobile telephone**  
Pre-installed bracket ..... 279
- MP3**  
Operating ..... 218  
see Separate operating instructions
- Multifunction display**  
Function/notes ..... 214  
Permanent display ..... 221
- Multifunction steering wheel**  
Back button ..... 214  
Operating the on-board computer . 213  
Overview ..... 31
- N**
- Navigation**  
Menu (on-board computer) ..... 216  
see separate operating instructions
- NECK-PRO head restraints**  
Operation ..... 42  
Resetting after being triggered ..... 43
- Notes on running in a new vehicle** .. 142
- O**
- Occupant safety**  
Children in the vehicle ..... 48  
Important safety notes ..... 38
- Odometer**  
see Total distance recorder  
see Trip meter
- Off-road**  
Differential locks ..... 204  
Off-road ABS ..... 61

<b>Off-road driving</b>	
Checklist .....	170
Driving on sand .....	171
Important safety notes .....	169
Travelling uphill .....	172
<b>Off-road fording</b> .....	167
<b>Off-road system</b>	
4MATIC .....	197
<b>Oil</b>	
see Engine oil	
<b>On-board computer</b>	
AMG menu .....	225
Assistance menu .....	220
Audio menu .....	217
Convenience submenu .....	224
Display messages .....	228
DISTRONIC PLUS .....	187
Factory setting submenu .....	225
Heating submenu .....	223
Important safety notes .....	210
Instrument cluster submenu .....	221
Light submenu .....	222
Menu overview .....	214
Message memory .....	228
Navigation menu .....	216
Operating video DVD .....	218
Operation .....	213
RACETIMER .....	226
Service menu .....	220
Settings menu .....	221
Standard display .....	215
Telephone menu .....	218
Trip menu .....	215
Vehicle submenu .....	223
<b>Operating safety</b>	
Diagnostics connection .....	22
<b>Operating system</b>	
see On-board computer	
<b>Outside temperature display</b> .....	212
<b>Overhead control panel</b> .....	34
<b>Override feature</b>	
Rear side windows .....	60
<b>P</b>	
<b>Paint code</b> .....	336
<b>Paintwork (cleaning instructions)</b> ...	293
<b>Parking</b> .....	163
Engaging park position .....	150
Important safety notes .....	163
Position of exterior mirror, front- passenger side .....	101
see PARKTRONIC	
<b>Parking aid</b>	
see Exterior mirrors	
see PARKTRONIC	
<b>Parking brake</b>	
Display message .....	231
Operating .....	164
Warning lamp .....	259
<b>Parking lamps</b>	
Changing bulbs .....	116
Display message .....	236
Switching on/off .....	108
<b>Parking lamps (changing bulbs)</b> .....	116
<b>PARKTRONIC</b>	
Deactivating/activating .....	199
Driving system .....	197
Function/notes .....	197
Important safety notes .....	197
Problem (fault) .....	200
Sensor range .....	198
Trailer towing .....	199
Warning display .....	199
<b>PASSENGER AIRBAG OFF warning lamp</b> .....	50
<b>Petrol</b> .....	338
<b>Plastic trim (cleaning instructions)</b> .	296
<b>Power supply (trailer)</b> .....	208
<b>Programming</b>	
Key .....	69
<b>Program selector button</b> .....	152
<b>Pulling away</b>	
Automatic transmission .....	144
<b>Q</b>	
<b>Qualified specialist workshop</b> .....	22
<b>R</b>	
<b>RACETIMER</b>	
Deleting all laps .....	227
Displaying and starting .....	226
Displaying the intermediate time ...	226

- Resetting the current lap ..... 227
- Starting a new lap ..... 226
- Stopping ..... 226
- RACETIMER (on-board computer) .... 226**
- Radar sensors**
  - Overview ..... 347
- Radiator cover ..... 287**
- Radio**
  - Selecting a station ..... 217
  - see separate operating instructions
- Reading lamp ..... 110**
- Rear bench seat**
  - Folding forward ..... 270
- Rear compartment**
  - Setting the air vents ..... 140
- Rear-compartment seat belt status indicator ..... 47**
- Rear door**
  - Closing ..... 76
  - Display message ..... 249
  - Important safety notes ..... 75
  - Opening ..... 75
  - Opening/closing ..... 75
- Rear foglamp**
  - Display message ..... 236
  - Switching on/off ..... 107
- Rear lamps**
  - see Lights
- Rear seat bench**
  - Folding into an upright position .... 270
- Rear-view mirror**
  - Anti-dazzle mode (automatic) ..... 100
- Rear window heating**
  - Problem (fault) ..... 133
  - Switching on/off ..... 133
- Rear window wiper**
  - Switching on/off ..... 120
- Refuelling**
  - Fuel gauge ..... 211
  - Important safety notes ..... 156
  - Refuelling process ..... 157
  - see Fuel
- Remote control**
  - Auxiliary heating/ventilation ..... 135
  - Changing the batteries (auxiliary heating) ..... 137
  - Programming (garage door opener) ..... 280
- Reserve (fuel tank)**
  - see Fuel
- Reserve fuel**
  - Display message ..... 240
  - Warning lamp ..... 260
- Residual heat**
  - Switching on/off ..... 133
- Restraint systems**
  - see SRS (Supplemental Restraint System)
- Rev counter ..... 212**
- Reversing camera**
  - Function/notes ..... 200
- Reversing camera (cleaning instructions) ..... 295**
- Reversing lamp**
  - Changing bulbs ..... 118
- Reversing lamp (display message) . . 236**
- Roof**
  - see Soft top
- Roof load (maximum) ..... 344**
- Route (navigation)**
  - see Route guidance (navigation)
- Route guidance (navigation) ..... 216**

## S

- Safety**
  - Children in the vehicle ..... 48
  - Child restraint systems ..... 48
- Safety net**
  - Detaching and storing ..... 274
  - Important safety information ..... 272
  - Releasing ..... 274
  - with luggage compartment enlargement ..... 273
  - without luggage compartment enlargement ..... 272
- Safety systems**
  - see Driving safety systems

- Seat**
  - Folding the front seat backrests forwards (EASY-ENTRY feature) ..... 94
- Seat backrest**
  - Folding back ..... 269
- Seat belt**
  - Adjusting the height ..... 46
  - Belt force limiter ..... 47
  - Belt tensioner ..... 47
  - Cleaning ..... 297
  - Display message ..... 232
  - Fastening ..... 44
  - Fastening, front ..... 44
  - Fastening in the rear, centre ..... 45
  - Important safety guidelines ..... 43
  - Rear seat belt status indicator ..... 47
  - Releasing ..... 46
  - Warning lamp ..... 252
  - Warning lamp (function) ..... 47
- Seat heating**
  - Malfunction indicator lamp ..... 96
- Seats**
  - Adjusting (electrically) ..... 92
  - Adjusting the 4-way lumbar support ..... 94
  - Adjusting the head restraint ..... 92
  - Cleaning the cover ..... 296
  - Correct driver's seat position ..... 90
  - Important safety notes ..... 91
  - Overview ..... 91
  - Storing settings (memory function) ..... 102
  - Switching seat heating on/off ..... 95
  - Switching the seat ventilation on/off ..... 96
- Seat ventilation**
  - Malfunction indicator lamp ..... 97
- Securing a load** ..... 270
- Sensors (cleaning instructions)** ..... 294
- Service menu (on-board computer)** . 220
- Service products**
  - AdBlue® special additives ..... 341
  - Brake fluid ..... 342
  - Coolant (engine) ..... 343
  - Engine oil ..... 341
  - Fuel ..... 337
  - Important safety notes ..... 337
  - Notes ..... 337
  - Washer fluid ..... 343
- Settings**
  - Calling up a stored setting ..... 102
  - Factory (on-board computer) ..... 225
  - On-board computer ..... 221
- Setting the air distribution** ..... 131
- SETUP (on-board computer)** ..... 226
- Shift ranges** ..... 153
- Short journeys (diesel particle filter)** ..... 164
- Side lamps**
  - Switching on/off ..... 107
- Side windows**
  - Convenience opening ..... 78
  - Important safety notes ..... 77
  - Opening/closing ..... 77
  - Overview ..... 77
  - Troubleshooting ..... 78
- Ski rack** ..... 275
- Sliding sunroof**
  - Important safety information ..... 79
  - Opening/closing ..... 79
  - Operating manually ..... 79
  - Problem (malfunction) ..... 80
- Snow chains** ..... 320
- Socket**
  - Front-passenger footwell ..... 278
  - Luggage compartment ..... 278
  - Rear compartment ..... 278
- Soft top**
  - Closing ..... 82
  - Closing manually in an emergency ... 82
  - Important safety notes ..... 81
  - Opening ..... 81
  - Troubleshooting ..... 87
- Spare fuses** ..... 314
- Spare wheel**
  - Fitting ..... 325
  - Notes/data ..... 329
  - Spare wheel bracket at the rear ... 303
  - Stainless-steel spare wheel cover .. 304
- Specialist workshop** ..... 22
- Speed, controlling**
  - see Cruise control
- Speedometer**
  - Digital ..... 216

- In the Instrument cluster ..... 211
  - Segments ..... 212
  - Selecting the unit of measurement ..... 221
  - see Instrument cluster
  - SPEEDTRONIC**
    - Display message ..... 244
    - Permanent ..... 182
    - Selecting ..... 179
    - Variable ..... 178
  - SRS (Supplemental Restraint System)**
    - Display message ..... 233
    - Introduction ..... 39
    - Warning lamp ..... 259
    - Warning lamp (function) ..... 39
  - Starting the engine**
    - Important safety notes ..... 144
  - Steering (display message)** ..... 250
  - Steering wheel**
    - Adjusting (electrically) ..... 97
    - Buttons (on-board computer) ..... 213
    - Gearshift paddles ..... 153
    - Important safety notes ..... 97
    - Steering wheel heating ..... 97
    - Storing settings (memory function) ..... 102
  - Steering wheel gearshift paddles** .... 153
  - Steering wheel heating**
    - Malfunction indicator lamp ..... 98
  - Stopwatch (RACETIMER)** ..... 226
  - Stowage areas** ..... 267
  - Stowage compartment**
    - Map pockets ..... 268
  - Stowage compartments**
    - Armrest (underneath) ..... 268
    - Cup holder ..... 275
    - Glove compartment ..... 267
    - Important safety information ..... 267
  - Summer tyres** ..... 319
  - Sun visor** ..... 276
  - Supplemental Restraint System**
    - see SRS (Supplemental Restraint System)
  - Supplement Restraint System**
    - see SRS (Supplemental Restraint System)
  - Surround lighting (on-board computer)** ..... 222
  - Suspension tuning**
    - SETUP (on-board computer) ..... 226
  - Switching off the alarm (ATA)** ..... 64
- T**
- Tailgate**
    - Display message ..... 249
    - Opening dimensions ..... 344
  - Tailgate (Cabriolet)**
    - Opening/closing ..... 76
    - opening the cover ..... 300
  - Tail lamps**
    - Display message ..... 236
    - see Lights
  - Technical data**
    - Capacities ..... 337
    - Information ..... 334
    - Trailer loads ..... 346
    - Tyres ..... 329
    - Tyres/wheels ..... 329
    - Vehicle data ..... 344
    - Wheels ..... 329
  - Telephone**
    - Accepting a call ..... 219
    - Display message ..... 251
    - Menu (on-board computer) ..... 218
    - Number from the phone book ..... 219
    - Redialling ..... 220
    - Rejecting/ending a call ..... 219
  - Telephone compartment** ..... 268
  - Temperature**
    - Coolant ..... 212
    - Coolant (on-board computer) ..... 225
    - Engine oil (on-board computer) ..... 225
    - Outside temperature ..... 212
    - Setting (climate control) ..... 131
  - TEMPOMAT**
    - Function/notes ..... 173
  - Theft-deterrent system**
    - ATA (Anti-Theft Alarm system) ..... 64
    - Immobiliser ..... 64
  - Tilt/sliding sunroof**
    - see Sliding sunroof
  - Time**
    - see Separate Owner's manual

- Timing (RACETIMER)** ..... 226
- Tonneau cover** ..... 85
- Top Tether** ..... 52
- Total distance recorder** ..... 215
- Tow-away protection** ..... 65
- Towing**
- Important safety notes ..... 311
  - In the event of malfunctions ..... 313
- Towing a trailer**
- Active Blind Spot Assist ..... 196
  - Axle load, permissible ..... 346
  - Trailer tow hitch ..... 346
- Towing away**
- With both axles on the ground ..... 313
- Towing eye**
- Front ..... 312
  - Rear ..... 312
- Tow-starting**
- Important safety notes ..... 311
- Trailer**
- 7-pin connector ..... 208
  - Power supply ..... 208
- Trailer coupling (cleaning instructions)** ..... 295
- Trailer loads**
- Technical data ..... 346
- Trailer towing**
- Blind Spot Assist ..... 192
  - Driving tips ..... 206
  - ESP® ..... 63
  - Lights display message ..... 234
  - Mounting dimensions ..... 346
  - Parktronic ..... 199
  - Shift range ..... 152
  - Trailer loads ..... 346
- Transfer case**
- General notes ..... 201
  - Shifting ..... 202
  - Shifting (general notes) ..... 202
  - Shifting (important safety notes) ... 202
  - Shifting to neutral ..... 203
  - Shift range ..... 201
  - Switching off the off-road gear ratio ..... 203
  - Switching on the off-road gear ratio ..... 202
- Transmission**
- see Automatic transmission
- Transmission positions** ..... 151
- Transport (vehicle)** ..... 313
- Travelling uphill**
- Brow of hill ..... 173
- Trip computer (on-board computer)** ..... 215
- Trip meter**
- Calling up ..... 215
  - Resetting (on-board computer) ..... 216
- Turn signals**
- Changing bulbs (front) ..... 117
  - Switching on/off ..... 108
- Two-way radio**
- Frequencies ..... 335
  - Installation ..... 335
  - Transmission output (maximum) ... 335
- Type identification plate**
- see Vehicle identification plate
- Tyre pressure**
- Calling up (on-board computer) ..... 323
  - Checking manually ..... 323
  - Display message ..... 245
  - Recommended ..... 321
  - Table (single tyres) ..... 322
- Tyre pressure monitor**
- Checking the tyre pressure electronically ..... 324
  - Function/notes ..... 323
  - Restarting ..... 324
  - Warning lamp ..... 263
  - Warning message ..... 324
- Tyres**
- Changing a wheel ..... 325
  - Checking ..... 319
  - Direction of rotation ..... 326
  - Display message ..... 245
  - Grip ..... 166
  - Important safety notes ..... 318
  - Replacing ..... 325
  - Service life ..... 319
  - Storing ..... 326
  - Technical data ..... 329
  - Tyre size (data) ..... 329
  - Tyre tread ..... 319
  - see Flat tyre

<b>U</b>	
<b>Unladen weight</b> .....	344
<b>Unlocking</b>	
Emergency unlocking .....	74
From inside the vehicle (central unlocking button) .....	73
<b>V</b>	
<b>Vanity mirror</b>	
Sun visor .....	276
<b>Variable SPEEDTRONIC</b>	
Function/notes .....	178
<b>Vehicle</b>	
Correct use .....	23
Data acquisition .....	23
Display message .....	248
Electronics .....	335
Emergency locking .....	75
Emergency unlocking .....	74
Equipment .....	21
Implied warranty .....	23
Individual settings .....	221
Leaving parked up .....	164
Locking (key) .....	68
Lowering .....	328
Pulling away .....	144
Raising .....	326
Registration .....	22
Securing from rolling away .....	326
Towing away .....	311
Tow-starting .....	311
Transporting .....	313
Unlocking (key) .....	68
Vehicle data .....	344
<b>Vehicle data</b> .....	344
<b>Vehicle dimensions</b> .....	344
<b>Vehicle identification number</b>	
see VIN	
<b>Vehicle identification plate</b> .....	336
<b>Vehicle tool kit</b> .....	302
<b>Vehicle tool kit pocket</b> .....	302
<b>Vehicle weights</b> .....	344
<b>Ventilation</b>	
Setting the airflow .....	131
<b>Video</b>	
Operating the DVD .....	218
<b>VIN</b> .....	336
<b>W</b>	
<b>Warning and indicator lamps</b>	
ABS .....	254
Brakes .....	253
Distance warning signal .....	262
ESP® .....	256
ESP® OFF .....	257
Fuel tank .....	260
LIM (cruise control) .....	174
LIM (DISTRONIC PLUS) .....	183
LIM (variable SPEEDTRONIC) .....	179
Overview .....	29, 251
Parking brake .....	259
PASSENGER AIRBAG OFF .....	50
Preglow .....	260
Seat belt .....	252
SRS .....	259
Tyre pressure monitor .....	263
<b>Warning triangle</b> .....	300
<b>Washer fluid</b>	
Display message .....	251
<b>Wheel bolt tightening torque</b> .....	328
<b>Wheels</b>	
Changing/replacing .....	325
Changing a wheel .....	325
Checking .....	319
Cleaning .....	293
Cleaning (warning) .....	326
Fitting a new wheel .....	328
Fitting a wheel .....	326
Important safety notes .....	318
Overview .....	318
Removing a wheel .....	328
Storing .....	326
Technical data .....	329
Tightening torque .....	328
Wheel size/tyre size .....	329
<b>Windowbag</b>	
Display message .....	234
Operation .....	42
<b>Windows</b>	
see Side windows	
<b>Windows (cleaning instructions)</b> .....	294
<b>Windscreen</b>	
Demisting .....	131

<b>Windscreen heating</b> .....	132
<b>Windscreen washer fluid</b>	
see Windscreen washer system	
<b>Windscreen washer system</b>	
Notes .....	343
Topping up .....	290
<b>Windscreen wipers</b>	
Problem (malfunction) .....	121
Rear window wiper .....	120
Replacing the wiper blades .....	120
Switching on/off .....	119
<b>Winter</b>	
Driving in winter .....	168
Winter operation .....	319
<b>Winter operation</b>	
Overview .....	319
Snow chains .....	320
<b>Winter tyres</b>	
Limiting the speed (on-board com- puter) .....	223
M+S tyres .....	320
<b>Wiper blades</b>	
Cleaning .....	294
Important safety notes .....	120
Replacing .....	120

## Protection of the environment

### General notes

#### 🌱 Environmental note

Daimler's declared policy is one of comprehensive environmental protection.

The objectives are for the natural resources which form the basis of our existence on this planet to be used sparingly and in a manner which takes the requirements of both nature and humanity into account.

You too can help to protect the environment by operating your vehicle in an environmentally-responsible manner.

Fuel consumption and the rate of engine, transmission, brake and tyre wear depend on the following factors:

- operating conditions of your vehicle
- your personal driving style

You can influence both factors. You should bear the following in mind:

Operating conditions:

- avoid short trips as these increase fuel consumption.
- make sure that the tyre pressures are always correct.
- do not carry any unnecessary weight.
- keep an eye on the vehicle's fuel consumption.
- remove roof racks once you no longer need them.
- a regularly serviced vehicle will contribute to environmental protection. You should therefore adhere to the service intervals.
- always have service work carried out at a qualified specialist workshop.

Personal driving style:

- do not depress the accelerator pedal when starting the engine.
- do not warm up the engine with the vehicle stationary.
- drive carefully and maintain a safe distance from the vehicle in front.

- avoid frequent, sudden acceleration.
- change gear in good time and use each gear only up to  $\frac{2}{3}$  of its maximum engine speed.
- switch off the engine in stationary traffic.

## Returning an end-of-life vehicle

Mercedes-Benz will take back your Mercedes-Benz to dispose of it in an environmentally responsible manner, in accordance with the European Union (EU) End of Life Vehicles Directive.

The End of Life Vehicles Directive applies to vehicles with a gross vehicle weight of up to 3.5 t, in accordance with national regulations. For several years, Mercedes-Benz has been meeting all the legal requirements for a design which allows for recycling and re-use. There is a network of return points and disassembly plants which can recycle your vehicle in an environmentally-responsible manner. The methods employed in vehicle and parts recycling are constantly being developed and improved. This means that your Mercedes-Benz will also continue to meet even the increased recycling quotas in the future in good time. You can obtain further information from your national Mercedes-Benz homepage or your national hotline number.

## Owner's Manual

### General notes

Before you first drive off, read this Owner's Manual carefully and familiarise yourself with your vehicle.

For your own safety and a longer vehicle life, follow the instructions and warning notices in this manual. Disregarding them may lead to damage to the vehicle or personal injury.

## Vehicle equipment

This Owner's Manual describes all models and all standard and optional equipment of your vehicle available at the time of publication of the Owner's Manual. Country-specific differences are possible. Note that your vehicle may not be fitted with all features described. This is also the case for systems and functions relevant to safety. Therefore, the equipment on your vehicle may differ from that in the descriptions and illustrations.

The original purchase contract documentation for your vehicle contains a list of all of the systems in your vehicle.

Should you have any questions concerning equipment and operation, please consult a Mercedes-Benz Service Centre.

The Owner's Manual and the Service Booklet are important documents and should be kept in the vehicle.

## Operating safety

### Important safety notes

#### **WARNING**

All work on the vehicle and, in particular, work relevant to safety or on safety-related systems must be carried out at a qualified specialist workshop. The specialist workshop must have the necessary specialist knowledge and tools to carry out the work required. Mercedes-Benz recommends that you use a Mercedes-Benz Service Centre for this purpose.

#### **WARNING**

Some safety systems only function when the engine is running. You should therefore never switch off the engine when driving. Otherwise, the safety systems of your vehicle may not function correctly and as a result will no longer protect you and other persons as intended. In addition, there is a risk that you may lose control of your vehicle and thus cause an accident.

#### **WARNING**

Work carried out incorrectly, or alterations made to the vehicle, e.g. re-routing of cables under coverings, could cause the safety systems of your vehicle to stop working properly. The safety systems would thus no longer protect you and other persons as intended. In addition, there is a risk that you may lose control of your vehicle and thus cause an accident.

All work and alterations to the vehicle, e.g. installations or modifications, should therefore be carried out at a qualified specialist workshop.

#### **WARNING**

If work on electronic equipment and its software is carried out incorrectly, this equipment could stop working. The electronic systems are networked via interfaces. Tampering with these electronic systems could cause malfunctions in systems which have not been modified. Malfunctions such as these can seriously jeopardise the vehicle's operating safety and therefore your own safety.

You should therefore have all work and modifications to electronic components carried out at a qualified specialist workshop.

#### **WARNING**

If you drive over obstacles at high speed or if the vehicle bottoms out in rough terrain, it could cause heavy impacts to the vehicle underbody, tyres or wheels. This could cause your vehicle to be damaged, which in turn might lead to an accident. This also applies to vehicles which are equipped with underbody protection.

You should therefore drive over obstacles slowly. Prevent the vehicle from bottoming out when driving off-road and if necessary, have your vehicle inspected at a qualified specialist workshop.

## Declarations of conformity

### Wireless vehicle components

The following information applies to all components of the vehicle and the COMAND system which receive and/or transmit radio waves:

The components of this vehicle which receive and/or transmit radio waves are compliant with the basic requirements and other relevant provisions of Directive 1999/5/EC. You can obtain further information from any Mercedes-Benz Service Centre.

### Electromagnetic compatibility

The electromagnetic compatibility of the vehicle components has been tested and certified in accordance with the current version of Directive 72/245/EEC or the equivalent ECE-R 10 regulation.

## Diagnostics connection

### WARNING

If you connect equipment to a diagnostics connection, it can affect the operation of the vehicle systems. This could compromise the operating safety of your vehicle while driving. There is a risk of an accident.

Do not connect any equipment to a diagnostics connection.

### WARNING

Loose equipment or cables hanging from a device which are connected to a diagnostic connection could impede pedal clearance. The equipment or cables could get caught between the pedals when driving and braking suddenly. This could impair the function of the pedals. There is a risk of accident.

Do not attach any equipment or cables in the driver's footwell.

 If the engine is switched off and equipment on the diagnostics connection is used, the starter battery may discharge.

The diagnostics connection is only intended for the connection of diagnostic equipment at a qualified specialist workshop.

Connecting equipment to the diagnostics connection can lead to emissions monitoring information being reset, for example. This may lead to the vehicle failing to meet the requirements of the next emissions test during the main inspection.

## Qualified specialist workshop

A qualified specialist workshop has the necessary special skills, tools and qualifications to correctly carry out any necessary work on your vehicle. This particularly applies to work relevant to safety.

Observe the notes in the Service Booklet.

Always have the following work carried out at a qualified specialist workshop:

- work relevant to safety
- service and maintenance work
- repair work
- modifications, installations and conversions
- work on electronic components

Mercedes-Benz recommends that you use a Mercedes-Benz Service Centre.

## Vehicle registration

Mercedes-Benz may ask its Service Centres to carry out technical inspections on certain vehicles. The quality or safety of the vehicle is improved as a result of the inspection.

Mercedes-Benz can only inform you about vehicle checks if it has your registration data.

It is possible that your vehicle has not yet been registered in your name in the following cases:

- if your vehicle was not purchased at an authorised specialist dealer.
- if your vehicle has not yet been examined at a Mercedes-Benz Service Centre.

It is advisable to register your vehicle with a Mercedes-Benz Service Centre.

Inform Mercedes-Benz as soon as possible about any change in address or vehicle ownership.

### Correct use

#### WARNING

Various warning stickers are affixed to your vehicle. Their purpose is to draw your attention, and the attention of others, to various dangers. Therefore, do not remove any warning stickers unless the sticker clearly states that you may do so.

If you remove the warning stickers, you or others could be injured by failing to recognise certain dangers.

When driving your vehicle observe the following information:

- the safety notes in this manual
- the Technical Data section in this manual
- traffic rules and regulations
- laws and safety standards pertaining to motor vehicles

### Implied warranty

- !** Follow the instructions in this manual about the proper operation of your vehicle as well as about possible vehicle damage. Damage to your vehicle that arises from culpable contraventions against these instructions are not covered either by Mercedes-Benz implied warranty or by the New or Used-Vehicle Warranty.

### Data stored in the vehicle

#### Fault data

Components which are critical for vehicle operation are equipped with fault data memories as standard. There are also data storage devices which record how vehicle components have reacted in certain driving situations (e.g. airbag deployment or ESP<sup>®</sup> intervention).

This data is used exclusively to:

- assist in the rectification of faults and defects
- help Mercedes-Benz optimise and develop vehicle functions

The data cannot be used to trace the vehicle's movements.

When your vehicle is serviced by Mercedes-Benz, this technical information can be read out from the fault memory. This is performed by authorised employees of the Mercedes-Benz service network using special diagnostic computers.

After a fault has been rectified, the information is deleted from the memory. Other memory data is constantly overwritten.

#### Other devices that store data

Depending on the equipment level, your vehicle may feature communications and/or entertainment systems (e.g. navigation devices, telephone systems). These allow you to save and edit data required for the operation of the respective device.

Further information on operation (e.g. on deleting data) can be found in the separate operating instructions.

#### Copyright information

##### FreeType

Portions of this software are copyright © 2005 The FreeType Project ([www.freetype.org](http://www.freetype.org)). All

rights reserved. © 1996-2000 by David Turner, Robert Wilhelm, and Werner Lemberg.

### Gnu compiler

Copyright © 1982, 1986 Regents of the University of California. All rights reserved.

The Berkeley software License Agreement specifies the terms and conditions for redistribution. Redistribution and use in source and binary forms, with or without modification, are permitted provided that the following conditions are met:

1. Redistribution of source code must retain the above copyright notice, this list of conditions and the following disclaimer.
2. Redistribution in binary form must reproduce the above copyright notice, this list of conditions and the following disclaimer in the documentation and/or other materials provided with the distribution.
3. All advertising materials mentioning features or use of this software must display the following acknowledgement: This product includes software developed by the University of California, Berkeley and its contributors.
4. Neither the name of the University nor the names of its contributors may be used to endorse or promote products derived from this software without specific prior written permission.

THIS SOFTWARE IS PROVIDED BY THE REGENTS AND CONTRIBUTORS "AS IS" AND ANY EXPRESS OR IMPLIED WARRANTIES, INCLUDING, BUT NOT LIMITED TO, THE IMPLIED WARRANTIES OF MERCHANTABILITY AND FITNESS FOR A PARTICULAR PURPOSE ARE DISCLAIMED. IN NO EVENT SHALL THE REGENTS OR CONTRIBUTORS BE LIABLE FOR ANY DIRECT, INDIRECT, INCIDENTAL, SPECIAL, EXEMPLARY, OR CONSEQUENTIAL DAMAGES (INCLUDING, BUT NOT LIMITED TO, PROCUREMENT OF SUBSTITUTE GOODS OR SERVICES; LOSS OF USE, DATA, OR PROFITS; OR BUSINESS INTERRUPTION)

HOWEVER CAUSED AND ON ANY THEORY OF LIABILITY, WHETHER IN CONTRACT, STRICT LIABILITY, OR TORT (INCLUDING NEGLIGENCE OR OTHERWISE) ARISING IN ANY WAY OUT OF THE USE OF THIS SOFTWARE, EVEN IF ADVISED OF THE POSSIBILITY OF SUCH DAMAGE.

Cockpit .....	26
Instrument cluster .....	27
Multifunction steering wheel .....	31
Centre console .....	32
Overhead control panel .....	34
Door control panel .....	35

## Cockpit



	Function	Page
①	Combination switch	108
②	Steering wheel gearshift paddles	
③	Instrument cluster	211
④	Horn	
⑤	Overhead control panel	34
⑥	PARKTRONIC warning display	197
⑦	Climate control systems	124
⑧	Ignition lock	143
⑨	To adjust the steering wheel	97
⑩	Cruise control lever	174
⑪	Light switch	104
⑫	To open the bonnet	287

## Instrument cluster

## Displays and controls



**i** Instrument cluster: kilometres

	Function	Page
①	Speedometer with segments	212
②	Multifunction display	214
③	Rev counter	212
④	Coolant temperature gauge	212
⑤	Fuel gauge	
⑥	Instrument cluster lighting control	212



**i** Instrument cluster: miles

	Function	Page
①	Speedometer with segments	
②	Multifunction display	214
③	Rev counter	
④	Coolant temperature	
⑤	Fuel gauge	
⑥	Instrument cluster lighting control	

## Warning and indicator lamps

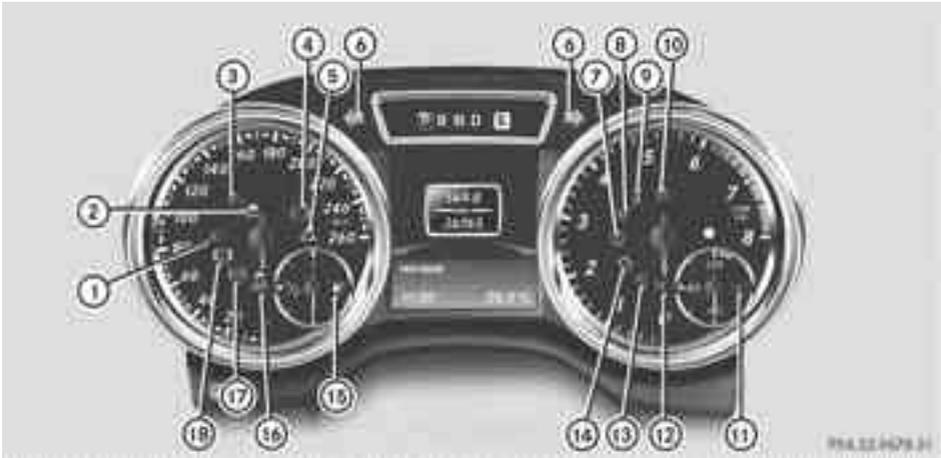

	Function	Page		Function	Page
①	 Dipped-beam headlamps	105	⑩	 Diesel engine: pre-glow	144
②	 ESP®	256	⑪	 Coolant	260
③	 Main-beam headlamp	109	⑫	 Rear foglamp	107
④	 Brakes (yellow)	253	⑬	 Front foglamps	106
⑤	 Distance warning	262	⑭	 Engine diagnostics	259
⑥	 Turn signals	108	⑮	 Reserve fuel	260
⑦	 Tyre pressure monitor	263	⑯	 ESP® OFF	256
⑧	 SRS	259	⑰	 ABS	254
⑨	 Seat belt	252	⑱	 Brakes (red)	253



	Function	Page
①	 Dipped-beam headlamps	105
②	 ESP®	256
③	 Main-beam headlamp	109
④	 Brakes (yellow)	253
⑤	 Distance warning	262
⑥	 Turn signals	108
⑦	 Tyre pressure monitor	263
⑧	 SRS	259
⑨	 Seat belt	252

	Function	Page
⑩	 Diesel engine: pre-glow	144
⑪	 Coolant	260
⑫	 Rear foglamp	107
⑬	 Front foglamps	106
⑭	 Engine diagnostics	259
⑮	 Reserve fuel	260
⑯	 ESP® OFF	256
⑰	 ABS	254
⑱	 BRAKE Brakes (red)	253

## Multifunction steering wheel



	Function	Page
①	Multifunction display	
②	Audio/COMAND display	
③	 Switches on LINGUA-TRONIC; see the separate operating instructions	
④	 Rejects or ends a call Exits telephone book / redial memory  Makes or accepts a call Switches to the redial memory  Adjusts the volume  Mute	

	Function	Page
⑤	 Selects a menu  Selects a submenu or scrolls through lists  Confirms selections and hides messages	
⑥	 Back Switches off LINGUA-TRONIC; see the separate operating instructions	

## Centre console

## Centre console, upper section



	Function	Page
①	Audio system; see the separate operating instructions COMAND Online	
②	Seat heating	95
③	 Seat ventilation	96
④	 PARKTRONIC	197
⑤	 ECO start/stop function <b>(AMG vehicles only)</b>	145

	Function	Page
⑥	 Hazard warning lamps	109
⑦	 Indicator lamp	50
⑧	 ESP®	62
⑨	 Auxiliary heating	134

## Centre console, lower section

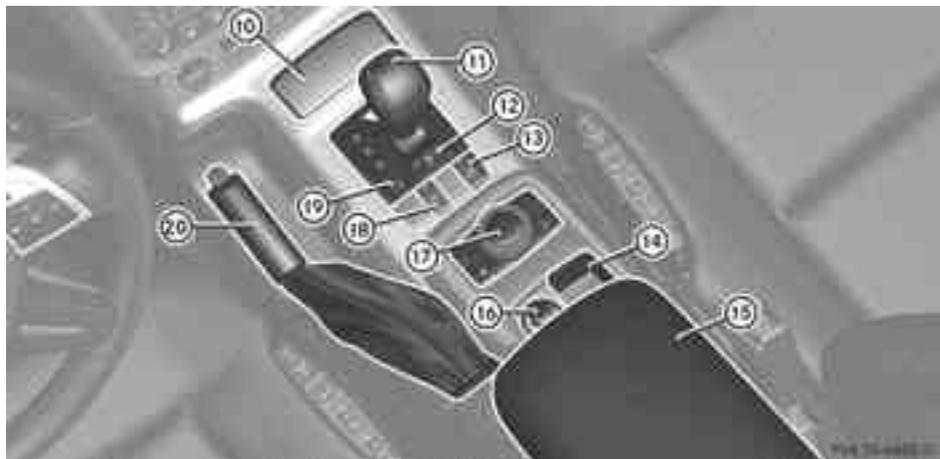

	Function	Page		Function	Page
⑩	Stowage compartment/ ashtray	277	⑯	Cigarette lighter	277
⑪	Automatic transmission selector lever	149	⑰	Audio controller, see the separate operating instruc- tions COMAND controller	
⑫	To select park position	150	⑱	 Selects the drive pro- gram	152
⑬	 Selects/deselects LOW RANGE off-road gear	202	⑳	Parking brake	164
⑭	Stowage compartment				
⑮	To open/close the stowage compartment	267			

## Overhead control panel

At a glance



	Function	Page
①	 Switches the left-hand reading lamp on/off	110
②	 Switches the front interior lighting on	112
③	 Switches the rear interior lighting on/off	112
④	 Switches the front interior lighting/automatic interior lighting control off	111
⑤	 Switches the right-hand reading lamp on/off	110

	Function	Page
⑥	 Opens/closes the sliding sunroof	79
⑦	 Deactivates tow-away protection	65
⑧	Rear-view mirror	99
⑨	Buttons for the garage door opener	282
⑩	 Deactivates the interior motion sensor	65

## Door control panel



	Function	Page
①	 Activates/deactivates the override feature for the side windows in the rear compartment	60
②	 Opens/closes the side windows	77
③	 Selects the left exterior mirror  Folds the exterior mirrors in/out  Selects the right exterior mirror  Adjusts the exterior mirrors electrically	99

	Function	Page
④	 Stores settings for the seat, exterior mirrors and steering wheel (memory function)	102
⑤	To adjust the seat	92
⑥	  Unlocks/locks the vehicle	73
⑦	To open the door	73



Useful information .....	38
Occupant safety .....	38
Children in the vehicle .....	48
Driving safety systems .....	60
Anti-theft systems .....	64

## Useful information

- i** This Owner's Manual describes all models, series and optional equipment for your vehicle that were available at the time of going to press. Country-specific differences are possible. Note that your vehicle may not be fitted with all features described. This is also the case for systems and functions relevant to safety.
- i** Read the information on qualified specialist workshops: (▷ page 22).

## Occupant safety

### Important safety notes

#### WARNING

If service work is not carried out correctly, the operating safety of your vehicle may be affected. This could cause you to lose control of your vehicle and cause an accident. Moreover, the safety systems may no longer be able to protect you or others as they are designed to do.

Always have service work carried out at a qualified specialist workshop.

#### WARNING

Modifications to or work performed incorrectly on the following parts can result in the restraint systems not functioning as intended:

- the restraint system, consisting of seat belts and their anchorage points, belt tensioners, belt force limiters and airbags
- the wiring
- networked electronic systems

Airbags and belt tensioners could fail to deploy or be triggered in an accident despite the deceleration force being sufficient to trigger the systems, or could be triggered unintentionally. For this reason, never make any modifications to the restraint systems.

Therefore, you must not tamper with electronic components or their software.

Seat belts, together with the Supplemental Restraint System, SRS (▷ page 39), are complementary, co-ordinated restraint systems. They reduce the risk of injury in specific, pre-defined types of accident situations and thereby increase occupant safety. However, seat belts and airbags generally do not protect against objects penetrating the vehicle from the outside.

To ensure that the restraint systems can deliver their full potential protection, make sure that:

- the seat and head restraint are adjusted properly (▷ page 90)
- the seat belt has been fastened properly (▷ page 44)
- the airbags can inflate properly if they are deployed (▷ page 40)
- the steering wheel is adjusted properly (▷ page 90)
- the restraint systems have not been modified

An airbag increases the protection of vehicle occupants wearing a seat belt. However, airbags are only an additional restraint system which complements, but does not replace, the seat belt. All vehicle occupants must wear their seat belt correctly at all times, even if the vehicle is equipped with airbags. The airbags are not deployed in all types of accidents. For example, if the protective capacity of correctly fastened seat belts is not increased by deploying the airbags, the airbags will not deploy.

Airbag deployment only provides increased protection if the seat belt is worn correctly. The seat belt helps, firstly, to keep the vehicle occupant in the best position in relation to the airbag. Secondly, in a head-on collision, for example, the seat belt prevents the vehicle occupant from being propelled towards the point of impact.

## SRS (Supplemental Restraint System)

### Introduction

SRS reduces the risk of occupants coming into contact with the vehicle's interior in the event of an accident. It can also reduce the forces to which occupants are subjected during an accident.

SRS consists of:

- the  SRS warning lamp
- airbags
- airbag control unit (with crash sensors)
- belt tensioners
- belt force limiters

### SRS warning lamp

#### WARNING

If SRS is malfunctioning, individual systems may be triggered unintentionally or might not be triggered in the event of an accident with a high rate of vehicle deceleration.

A malfunction has occurred if:

- the  SRS warning lamp does not light up when the ignition is switched on.
- the engine is running and the  SRS warning lamp does not go out after a few seconds.
- the engine is running and the  SRS warning lamp lights up again.

In this case, have SRS checked immediately at a qualified specialist workshop.

SRS functions are checked regularly when you switch on the ignition and when the engine is running. Therefore, malfunctions can be detected in good time.

The  SRS warning lamp in the instrument cluster lights up when the ignition is switched on. It goes out no later than a few seconds after the engine is started.

### Triggering of belt tensioners, belt force limiters and airbags

During the first stage of a collision, the airbag control unit evaluates important physical data relating to vehicle deceleration or acceleration, such as:

- duration
- direction
- magnitude

Based on the evaluation of this data, the airbag control unit pre-emptively triggers the belt tensioners in the first stage.

- i** The belt tensioners can only be triggered if the seat belt tongues are correctly engaged in the seat belt buckles.

If there is an even higher rate of vehicle deceleration or acceleration in a longitudinal direction, the front airbags are also deployed.

Your vehicle is equipped with a dual-stage driver's airbag and a single-stage front-passenger front airbag. The airbag control unit evaluates vehicle deceleration or acceleration in the event of a collision. In the first deployment stage, the driver's airbag is filled with enough propellant gas to reduce the risk of injuries. The front airbag is fully deployed if a second deployment threshold is exceeded within a few milliseconds. The front-passenger front airbag is filled with the maximum amount of propellant gas in one stage at the moment of impact.

The belt tensioner and airbag triggering thresholds are variable and are adapted to the rate of deceleration or acceleration of the vehicle. This process is pre-emptive in nature. The triggering process must take place in good time at the start of the collision.

- i** Airbags are not deployed in all types of accidents. Also, not all airbags are deployed together in an accident. The different airbag systems work independently of each other.

How the airbag system works is determined by the severity of the collision detected, especially the vehicle deceleration or acceleration, and the apparent type of accident:

- head-on collision
- side impact
- overturning
- rear impact

The rate of vehicle deceleration or acceleration and the direction of the force are essentially determined by:

- the distribution of forces during the collision
- the collision angle
- the deformation characteristics of the vehicle
- the characteristics of the object with which the vehicle has collided

Factors which can only be seen and measured after a collision has occurred do not play a decisive role in the deployment of an airbag, nor do they provide an indication of airbag deployment.

The vehicle may be deformed significantly, e.g. the bonnet or the wing, without an airbag being deployed. This is the case if only parts which are relatively easily deformed are affected and the rate of deceleration is not high. Conversely, airbags may be deployed even though the vehicle suffers only minor deformation. This is the case if, for example, very rigid vehicle parts such as longitudinal body members are hit, and sufficient deceleration occurs as a result.

## Airbags

### Important safety notes

#### WARNING

Airbags provide additional protection; they are not, however, a substitute for seat belts.

Observe the following notes to reduce the risk of serious or even fatal injury caused by airbag deployment:

- all vehicle occupants – in particular, pregnant women – must wear their seat belt correctly at all times and lean back against the backrest, which should be positioned as close to the vertical as possible. The head restraint must support the back of the head at about eye level.
  - always secure children less than 1.50 m tall and under 12 years of age in suitable child restraint systems.
  - all vehicle occupants must select a seat position that is as far away from the airbag as possible. The driver's seat position must allow the vehicle to be driven safely. The driver's chest should be as far away from the centre of the driver's airbag cover as possible.
  - move the front-passenger seat as far back as possible. This is especially important if you have secured a child in a child restraint system on the front-passenger seat.
  - vehicle occupants – in particular children – must not lean their head in the area of the window where the windowbag is deployed
  - rearward-facing child restraint systems must not be fitted to the front-passenger seat unless the front-passenger airbag has been disabled. On the front-passenger seat, the front-passenger airbag is disabled if a child restraint system with automatic child seat recognition is fitted to the front-passenger seat in a vehicle equipped with automatic child seat recognition. The  PASSENGER AIRBAG OFF indicator lamp must be continuously lit.
- If the front-passenger seat of your vehicle does not have automatic child seat recognition, or your rearward-facing child restraint system does not have automatic child seat recognition, children must be secured in a child restraint system on a suitable seat in the rear. If you secure a forward-facing child restraint system to the

front-passenger seat, you must move the front-passenger seat as far back as possible.

- make sure there are no heavy or sharp-edged objects in the pockets of clothing.
- do not lean forwards, e.g. over the cover of the driver's/front-passenger airbag, particularly when the vehicle is in motion.
- do not put your feet on the dashboard.
- only hold the steering wheel on the outside. This allows the airbag to be fully deployed. You could be injured if the airbag is deployed and you are holding the inside of the steering wheel.
- do not lean on the doors from inside the vehicle.
- make sure that there are no people, animals or objects between the vehicle occupants and the area where the airbags are deployed.
- do not place any objects between the seat backrest and the door.
- do not hang any hard objects, for example, coat hangers, on the grab handles or coat hooks.
- do not attach accessories, e.g. cup holders, to the doors.

It is not possible to rule out a risk of injury being caused by an airbag, due to the high speed at which the airbag must be deployed.

#### **WARNING**

The airbag's functionality can only be assured if the following parts are not covered and no badges or stickers are attached to them:

- padded steering wheel boss
- front-passenger front airbag cover

#### **WARNING**

When an airbag deploys, a small amount of powder is released. The powder may cause short-term breathing difficulties to persons suffering from asthma or other pulmonary conditions.

In order to prevent potential breathing difficulties, you should leave the vehicle as soon as it is safe to do so. You can also open the window to allow fresh air to enter the vehicle interior. The powder does not constitute a health hazard and does not indicate that there is a fire in the vehicle.

#### **WARNING**

The airbag parts are hot after the airbag has been deployed. Do not touch them as you could burn yourself.

Have the airbags replaced at a qualified specialist workshop. Otherwise, occupants are not protected by the airbags in the event of another accident.

Airbag deployment slows down and restricts the movement of the vehicle occupant.

If the airbags are deployed, you will hear a bang, and a small amount of powder may also be released. Only in rare cases will the bang affect your hearing. The powder that is released generally does not constitute a health hazard. The  SRS warning lamp lights up.

The airbag installation locations are identified by the AIRBAG symbol.

### **Front airbags**

- ❗ Do not place heavy objects on the front-passenger seat. The system may then detect that the seat is occupied and if there is an accident, the restraint systems on the front-passenger side could be deployed. Have restraint systems that have been triggered replaced.

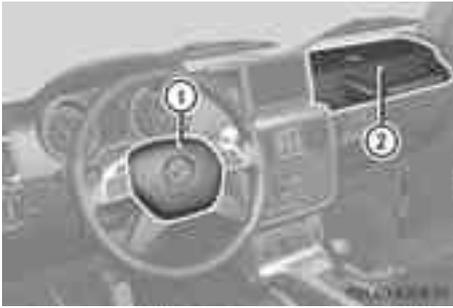

Driver's airbag ① deploys in front of the steering wheel; front-passenger front airbag ② deploys in front of and above the glove compartment.

The front airbags increase protection for the driver's and front-passenger's head, neck and chest.

They are deployed:

- at the start of an accident with a high rate of vehicle acceleration or deceleration in a longitudinal direction
- if the system determines that airbag deployment can offer additional protection to that provided by the seat belt
- independently of other airbags in the vehicle
- depending on whether the seat belt is being used

If the vehicle overturns, the front airbags are generally not deployed. The front airbags are deployed if the system detects high vehicle deceleration in a longitudinal direction.

Front-passenger airbag ② is only activated if the system determines that the front-passenger seat is occupied. The  PASSENGER AIRBAG OFF indicator lamp on the centre console does not light up (▷ page 50). This means that a child restraint system without automatic child seat recognition has been fitted to the front-passenger seat, or that a child restraint system with automatic child seat recognition has been fitted incorrectly.

## Windowbags

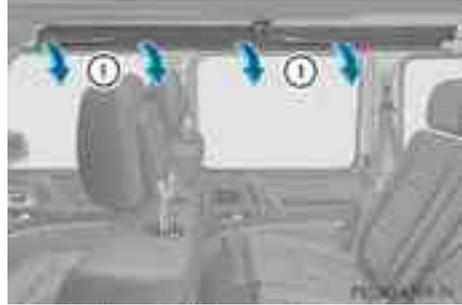

G-Class off-road vehicles, long-wheelbase version, are equipped with windowbags.

Windowbags ① enhance the level of protection for the head, but not chest or arms, of the vehicle occupants on the side of the vehicle on which the impact occurs.

Windowbags ① are integrated into the side of the roof frame and deploy in the area extending from the front door (A-pillar) to the rear door (C-pillar).

Windowbags ① are deployed:

- on the side on which an impact occurs
- at the start of an accident with a high rate of lateral vehicle deceleration or acceleration, e.g. in a side impact
- regardless of whether the front-passenger seat is occupied
- independently of seat belt use
- if the vehicle overturns and the system determines that windowbag deployment can offer additional protection to that provided by the seat belt
- independently of the front airbags

### NECK-PRO head restraints

#### Important safety notes

##### WARNING

Head restraint covers prevent the NECK-PRO head restraints from triggering correctly. Consequently, the NECK-PRO head restraints

cannot provide the intended level of protection. Do not use head restraint covers.

The NECK-PRO head restraints increase protection to the driver's and the front passenger's head and neck. The NECK-PRO head restraints on the driver's and front-passenger seats are moved forwards and upwards in the event of a rear-end collision of a certain severity. This provides better head support. If the NECK-PRO head restraints have been triggered in an accident, reset the NECK-PRO head restraints on the driver's and front-passenger seat (▷ page 43). Otherwise, the additional protection will not be available in the event of another rear-end collision. You can recognise if NECK-PRO head restraints have been triggered by the fact that they have moved forwards and can no longer be adjusted.

### Resetting triggered NECK-PRO head restraints



- ▶ Tilt the top of the NECK-PRO head restraint cushion forwards in the direction of arrow ①.
- ▶ Push the NECK-PRO head restraint cushion down in the direction of arrow ② as far as it will go.
- ▶ Firmly push the NECK-PRO head restraint cushion back in the direction of arrow ③ until the cushion engages.
- ▶ Repeat this procedure for the second NECK-PRO head restraint.

Mercedes-Benz recommends that you have the NECK-PRO head restraints checked at a qualified specialist workshop after a rear-end collision.

- ❗ Resetting the NECK-PRO head restraints requires a lot of strength. If you have difficulty resetting the NECK-PRO head restraints, have this work carried out at a qualified specialist workshop.

### Seat belts

#### Important safety notes

##### ⚠ WARNING

A seat belt which is not worn correctly, or which has not been engaged in the seat belt buckle correctly, cannot provide the intended level of protection. Under certain circumstances, this could cause severe or even fatal injuries in the event of an accident.

Therefore, make sure that all occupants – in particular, pregnant women – wear their seat belts correctly at all times.

- The seat belt must fit snugly on your body and must not be twisted. Therefore, avoid wearing bulky clothing, e.g. a winter coat. The shoulder section of the belt must be routed across the centre of your shoulder – on no account across your neck or under your arm – and pulled tight against your upper body. The lap belt must always pass across your lap as low down as possible, i.e. over your hip joints – not across your abdomen. If necessary, push the seat belt slightly downwards and adjust it by pulling it in the direction the seat belt retracts.
- Do not route the seat belt strap over sharp or fragile objects. Please make sure that such objects are not on or in your clothing, e.g. spectacles, pens or keys etc. The seat belt strap could become damaged and tear during an accident and you or other vehicle occupants could be injured.

- Only one person should use each seat belt at any one time. Children must never travel sitting on the lap of another occupant. The child will not be secured in the event of an accident, heavy braking or sudden change of direction. This may result in the child or other occupants being seriously or fatally injured.
- Persons under 1.50 m tall cannot wear the seat belts correctly. For this reason secure persons less than 1.50 m tall in specially designed, suitable restraint systems.
- Children under 1.50 m tall and younger than twelve years of age cannot wear the seat belts correctly. For this reason secure them in special suitable child restraint systems installed on a suitable seat. Additional information can be found in the Operating Instructions in the chapter "Safety", "Children in the Vehicle". Observe the installation instructions of the child restraint system manufacturer.
- Do not secure an object with a seat belt if the seat belt is also being used by one of the vehicle's occupants.

#### WARNING

The seat belt does not offer the intended level of protection unless the backrest is almost vertical. Under certain circumstances, this could cause severe or even fatal injuries in the event of an accident.

Before starting a journey, make sure that the seat is properly adjusted and that the backrest is almost vertical.

#### WARNING

A dirty or damaged seat belt or one that has been modified or subjected to a load in an accident no longer offers the intended level of protection. Under certain circumstances, this could cause severe or even fatal injuries in the event of an accident.

For this reason, check regularly that the seat belts are not damaged or dirty.

Always have damaged seat belts or seat belts that have been subjected to a load in an accident replaced at a qualified specialist workshop.

For safety reasons, Mercedes-Benz recommends that you only use seat belts which have been approved by Mercedes-Benz for your vehicle.

Seat belts are the most effective means of restraining the movement of vehicle occupants in the event of an accident. This reduces the risk of vehicle occupants coming into contact with parts of the vehicle interior.

## Fastening seat belts

### Three-point seat belt, front

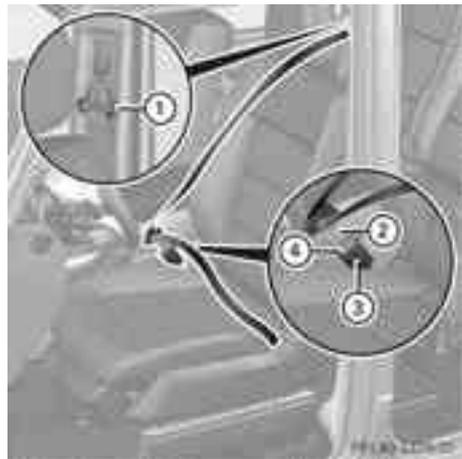

- ▶ Adjust the seat and move the backrest to an almost vertical position (▷ page 90).
- ▶ Pull the seat belt smoothly through belt sash guide ①.
- ▶ Without twisting it, guide the shoulder section of the seat belt across the middle of your shoulder and the lap section across your hips.
- ▶ Engage belt tongue ② in buckle ③.

- ▶ If necessary, adjust the seat belt to the appropriate height (▷ page 46).
- ▶ If necessary, pull upwards on the shoulder section of the seat belt to tighten the belt across your body.

Further information on releasing the seat belts with release button ④ (▷ page 46).

### Three-point seat belt in the rear, centre



- ① Bracket for seat belt tongues
- ② Belt buckle for fixed belt tongue
- ③ Release button for fixed belt tongue
- ④ Fixed belt tongue
- ⑤ Belt buckle for movable belt tongue
- ⑥ Release button for movable belt tongue
- ⑦ Movable belt tongue



- ▶ Pull both seat belt tongues ④ and ⑦ from bracket ①.



- ▶ Pull the seat belt smoothly from the inertia reel.
- ▶ Engage fixed seat belt tongue ④ in buckle ②.



- ▶ Pull movable seat belt tongue ⑦ and route the seat belt across your body. Without twisting it, guide the shoulder section of the seat belt across the middle of your shoulder and the lap section across your hips.
- ▶ Engage movable seat belt tongue ⑦ in buckle ⑤.
- ▶ If necessary, pull upwards on the shoulder section of the seat belt to tighten the belt across your body.

Further information on releasing the seat belts with release buttons ⑥ and ③ (▷ page 46).

### Belt height adjustment

You can adjust the belt height on the driver's and front-passenger seat, as well as on the outer rear seats.

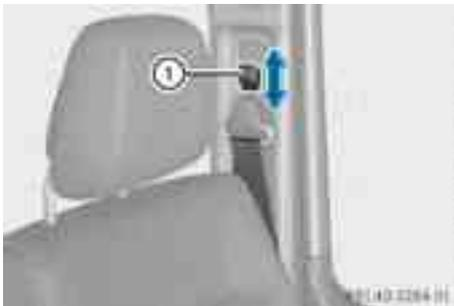

Adjust the height so that the upper part of the seat belt is routed across the centre of your shoulder.

- ▶ **To raise:** slide the belt sash guide upwards. The belt sash guide engages in various positions.
- ▶ **To lower:** draw belt sash guide release ① forwards and hold it.
- ▶ Slide the belt sash guide downwards.
- ▶ Let go of belt sash guide release ① and make sure that the belt sash guide has engaged.

### Releasing the seat belts

**!** Make sure that the seat belt is fully rolled up. Otherwise, the seat belt or belt tongue will be trapped in the door or in the seat mechanism. This could damage the door, the door trim panel and the seat belt. Damaged seat belts can no longer fulfil their protective function and must be replaced. Visit a qualified specialist workshop.

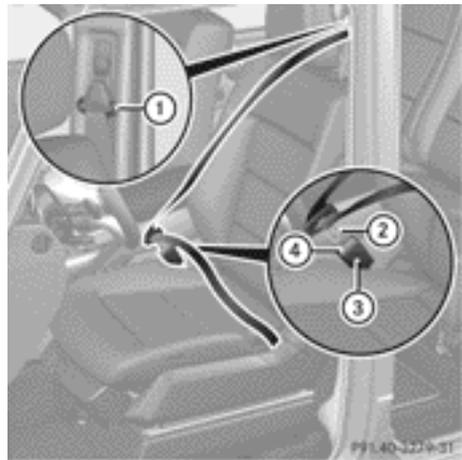

- ▶ Press release button ④ of buckle ③ and guide belt tongue ② back towards belt sash guide ①.

## Belt warning for the driver and front passenger

The  seat belt warning lamp in the instrument cluster is a reminder for all occupants to fasten their seat belts. It may light up continuously or flash. In addition, there may be a warning tone.

The  seat belt warning lamp goes out and the warning tone ceases when the driver and the front passenger have fastened their seat belt.

**For certain countries only:** regardless of whether the driver and the front passenger have fastened their seat belts, the  seat belt warning lamp lights up for six seconds after the engine is started. It then goes out if the driver and the front passenger have fastened their seat belts.

 Further information about the  seat belt warning lamp (> page 252).

## Rear seat belt status indicator

The rear-compartment seat belt status indicator tells you if the rear passengers have their seat belts fastened.

The rear-compartment seat belt status indicator indicates the rear seat on which the belt is fastened. The  symbol in the multifunction display indicates a fastened seat belt. If a seat belt is not fastened or if a seat is not occupied, the  symbol is displayed.

The rear-compartment seat belt status indicator appears in the multifunction display for around 30 seconds if:

- you drive off and reach a speed of approximately 10 km/h.
- the rear passengers fasten or unfasten their seat belts while the vehicle is in motion.
- someone gets in or out of the vehicle and the vehicle drives off again.

You can also cancel the rear seat belt status indicator immediately (> page 228).

 The status indicator for the rear-compartment seat belts is only available for certain countries.

## Belt tensioners, belt force limiters

### WARNING

The belt tensioners in the rear only function if the belt buckles can be pulled down unobstructed. They must not be restricted in any way. Therefore, do not grab the belt buckles and do not place any objects under the belt buckles. Otherwise, the tensioning of the belt by the buckle is restricted or will not function, and will not provide any additional protection.

### WARNING

If the seat belt tensioners have been triggered, they provide no additional protection in the event of another accident. Therefore, have belt tensioners which have been triggered replaced at a qualified specialist workshop.

Comply with safety regulations when disposing of belt tensioners. Any Mercedes-Benz Service Centre can provide details of these regulations.

 If the front-passenger seat is not occupied, do not engage the seat belt tongue in the buckle on the front-passenger seat. Otherwise, the belt tensioner could be triggered in the event of an accident.

► In order to ensure that the pyrotechnic seat belt tensioners have not been triggered, always have the seat belts checked after an accident.

If the belt tensioners have been triggered, they must be replaced.

The front seat belts and the outer seat belts in the rear are equipped with belt tensioners and belt force limiters.

The belt tensioners tighten the seat belts in an accident, pulling them close against the body.

Belt tensioners do not correct incorrect seat positions or incorrectly fastened seat belts.

Belt tensioners do not pull vehicle occupants back towards the backrest.

If the seat belt is also fitted with a belt force limiter and this is triggered, the force exerted by the seat belt on the vehicle occupant is reduced.

The front belt force limiters are synchronised with the front airbags, which take on a part of the deceleration force. Thus, the force exerted on the occupant is distributed over a greater area.

The belt tensioners can only be activated if:

- the key is in position **1** or **2** in the ignition lock.
- the restraint systems are operational; see "SRS warning lamp" (▷ page 39).
- for each three-point seat belt in front and for the outer rear seats, the seat belt tongue is engaged in the belt buckle.
- the front-passenger seat is occupied and the belt tongue is engaged in the buckle on the front-passenger side.

The belt tensioners are triggered depending on the type and severity of an accident:

- if, in the event of a head-on or rear-end collision, the vehicle decelerates or accelerates rapidly in a longitudinal direction during the initial stages of the impact
- if, in the event of a side impact, on the side opposite the impact the vehicle decelerates or accelerates rapidly in a lateral direction
- in certain situations where the vehicle overturns and the system determines that it can provide additional protection

If the airbags are deployed, you will hear a bang, and a small amount of powder may also be released. Only in rare cases will the bang affect your hearing. The powder that is released generally does not constitute a health hazard. The  SRS warning lamp lights up.

## Children in the vehicle

### Child restraint systems

#### Important safety notes

##### WARNING

To reduce the risk of serious or even fatal injury to the child in the event of a sudden change in direction, braking or an accident:

- children less than 1.50 m tall and under twelve years of age must always be secured in special child restraint systems on a suitable vehicle seat. This is necessary because the seat belts are not designed for children.
- do not secure children less than 1.50 m tall and under twelve years of age on the front-passenger seat. Exception: if the vehicle is equipped with automatic child seat recognition on the front-passenger seat and the child is secured in a child restraint system with transponders for automatic child seat recognition
- if you secure a forward-facing child restraint system to the front-passenger seat, you must move the front-passenger seat as far back as possible.
- children must never travel sitting on the lap of another occupant. Due to the forces which occur in the event of a sudden change of direction, heavy braking or an accident, it would not be possible to restrain the child. The child could be thrown against parts of the vehicle interior and be seriously or even fatally injured.

##### WARNING

The child restraint system cannot perform its protective function if it is not correctly fitted to a suitable vehicle seat. The child cannot be restrained in the event of an accident, heavy braking or sudden changes of direction. The child could be seriously or even fatally injured. For this reason, when fitting a child restraint system, observe the manufacturer's installa-

tion instructions and the correct use of the child restraint system.

Child restraint systems should be fitted to the rear seats. Children are generally better protected there.

The entire base of the child restraint system must always rest on the seat cushion. Therefore, never place objects, e.g. a cushion, under the child restraint system.

Only use child restraint systems with the original cover designed for them. Only replace damaged covers with genuine Mercedes-Benz covers.

We recommend the use of child restraint systems which have been approved for Mercedes-Benz vehicles.

#### **WARNING**

When leaving the vehicle, it can still roll away despite being braked by the HOLD function if:

- there is a malfunction in the system or in the voltage supply
- the HOLD function is deactivated by the accelerator pedal being depressed, e.g. by a vehicle occupant
- the electrical system in the engine compartment, the battery or the fuses are tampered with
- the battery is disconnected

There is a risk of an accident.

Before leaving the vehicle, always deactivate the HOLD function and secure the vehicle from rolling away.

#### **WARNING**

Unsecured or incorrectly positioned loads increase the risk of injury for children and all other occupants in the event of:

- an accident
- a braking manoeuvre
- a sudden change of direction

Do not carry heavy or hard objects in the vehicle interior unless they are secured. You will

find further information under "Loading guidelines" in the index.

If a child is travelling in your vehicle, secure the child using a child restraint system which is appropriate to the size, age and weight of the child and recommended for Mercedes-Benz vehicles. You should preferably fit the restraint system to a suitable rear seat. Make sure that the child is secured in a child restraint system throughout the trip.

Mercedes-Benz recommends that you only use the child restraint systems listed under (> page 56).

You can obtain information about the correct child restraint system from any Mercedes-Benz Service Centre.

-  It is advisable to use Mercedes-Benz care products to clean child restraint systems. You can obtain information about this at any Mercedes-Benz Service Centre.

### Child restraint system on the front-passenger seat

#### **WARNING**

If the front-passenger airbag is not disabled:

- a child secured in a child restraint system on the front-passenger seat could be seriously and even fatally injured by the front-passenger airbag deploying. This is especially a risk if the child is in the immediate vicinity of the front-passenger airbag when it deploys.
- never secure a child on the front-passenger seat in a rearward-facing child restraint system. Only secure a rearward-facing child restraint system on a suitable rear seat.
- always move the front-passenger seat to the rearmost position if you secure a child in a forward-facing child restraint system on the front-passenger seat.

The front-passenger airbag is not disabled:

- on vehicles without automatic child seat recognition on the front-passenger seat
- in vehicles with automatic child seat recognition in the front-passenger seat, if no special child restraint system with transponders for automatic child seat recognition in the front-passenger seat has been fitted
- on vehicles with automatic child seat recognition on the front-passenger seat, if the PASSENGER AIRBAG OFF indicator lamp  is not lit.

To make you aware of this danger, a corresponding warning sticker has been affixed on the dashboard and on both sides of the sun visor on the front-passenger side.

Information about recommended child restraint systems is available at any Mercedes-Benz Service Centre.



Example: warning notice on the front-passenger sun visor



Warning symbol for a rearward-facing child restraint system

Do not use a rearward-facing child restraint system on a seat that is protected by an airbag installed in front of it.

### Automatic child seat recognition on the front-passenger seat

#### WARNING

If the  PASSENGER AIRBAG OFF indicator lamp does not light up when the child restraint system is fitted, the front-passenger airbag has not been disabled. If the front-passenger airbag deploys, the child could be seriously or even fatally injured.

Proceed as follows:

- do not use a rearward-facing child restraint system on the front-passenger seat.
- fit a rearward-facing child restraint system on a suitable rear seat.

or

- only use a forward-facing child restraint system on the front-passenger seat and move the front-passenger seat to the rearmost position.
- have the automatic child seat recognition checked at a qualified specialist workshop.

To ensure that the automatic child seat recognition on the front-passenger seat functions/communicates correctly, never place objects, e.g. a cushion, under the child restraint system. The entire base of the child restraint system must always rest on the seat cushion. An incorrectly fitted child restraint system cannot perform its intended protective function in the event of an accident, and could lead to injuries.

#### WARNING

Do not place electronic devices on the front-passenger seat, e.g.:

- laptops, when switched on
- mobile phones
- cards with transponders, e.g. ski passes or access cards

Signals from electronic equipment can cause interference in the automatic child seat recognition sensor system. This can lead to a system malfunction. This may cause the  PASSENGER AIRBAG OFF indicator lamp to light up without there being a child seat with transponders for automatic child seat recognition fitted. The front-passenger airbag will not then deploy during an accident. It is also possible that the  SRS warning lamp lights up and/or the  PASSENGER AIRBAG OFF indicator lamp does not light up briefly when you turn the key in the ignition lock to position **2**.



The automatic child seat recognition sensor system on the front-passenger seat detects whether a special Mercedes-Benz child seat with automatic child seat recognition has been fitted there. In such cases,  PASSENGER AIRBAG OFF indicator lamp ① lights up. The front-passenger front airbag is disabled.

**i** If the front-passenger front airbag is disabled by the automatic child seat recognition, the following remain enabled on the front-passenger side:

- the windowbag
- the belt tensioner



If the front-passenger seat of your vehicle does not have automatic child seat recognition, this is indicated by a special sticker. The sticker is affixed to the side of the dashboard on the front-passenger side. The sticker is visible when you open the front-passenger door.

**Vehicles without automatic child seat recognition on the front-passenger seat:** if you turn the key to position **2** in the ignition lock, the  PASSENGER AIRBAG OFF indicator lamp lights up briefly but has no function. It does not indicate that there is automatic child seat recognition on the front-passenger seat.

### ISOFIX child seat securing system for the rear seats

#### **WARNING**

A child restraint system secured by the ISOFIX child seat securing system does not provide sufficient protection for children weighing more than 22 kg. For this reason, do not secure children weighing more than 22 kg in a child restraint system secured by the ISOFIX child seat securing system. If the child weighs more than 22 kg, secure the child restraint system with the vehicle seat belt as well. In addition, when fitting a child restraint system, be sure to observe the manufacturer's installation instructions and the instructions for correct use of the child restraint system.

**⚠ WARNING**

The child restraint system cannot perform its protective function if it is not correctly fitted to a suitable vehicle seat. The child cannot be restrained in the event of an accident, heavy braking or sudden changes of direction. The child could be seriously or even fatally injured. For this reason, when fitting a child restraint system, be sure to observe the manufacturer's installation instructions and the instructions for correct use of the child restraint system.

For safety reasons, when installing child restraint systems on the rear seats, only use child restraint systems with the ISOFIX child seat securing system, which are specially tested and approved for Mercedes-Benz vehicles.

An incorrectly fitted child restraint system could come loose and seriously or even fatally injure the child or other vehicle occupants. When fitting the child restraint system, always make sure that it is engaged correctly in the securing rings on both sides.

**⚠ WARNING**

Please note that if child restraint systems, or their retaining systems, are damaged or subjected to a load in an accident, they may not be able to provide their protective function. This could result in serious or even fatal injuries to the secured child in the event of an accident, heavy braking or a sudden change in direction.

For this reason, have child restraint systems and their anchorages which have been damaged or subjected to a load in an accident checked immediately at a qualified specialist workshop.

- !** When fitting the child restraint system, make sure that the seat belt for the centre seat does not get trapped. Otherwise, the seat belt could be damaged.

ISOFIX is a standardised securing system for specially designed child restraint systems on

the rear seats. Securing rings for two ISOFIX child restraint systems are fitted on the left and right of the rear seats.

**① Securing rings**

- ▶ Install the ISOFIX child restraint system. Comply with the manufacturer's instructions when installing the ISOFIX child restraint system.
- ▶ When an ISOFIX child seat securing system is installed, make sure that the centre seat belt in the rear compartment is fully functional and can move freely.

**Top Tether****⚠ WARNING**

For each child restraint system, use only the Top Tether anchorage in the correct position. Other Top Tether anchorages may tear in the event of an accident. The child could be seriously injured.

Ensure that:

- the fastening straps do not cross each other and are not twisted.
- the hook is hooked in correctly and is closed.

Top Tether provides an additional connection between the child restraint system secured with ISOFIX and the rear seat. It helps reduce the risk of injury even further.

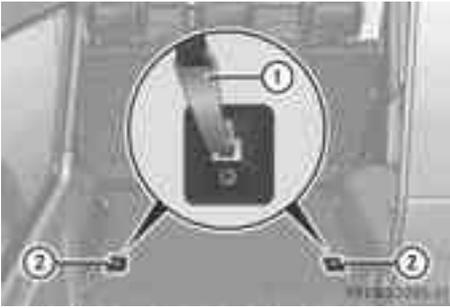

- ▶ Tension Top Tether belt (3). Comply with the manufacturer's installation instructions when doing so.
- ▶ Move the head restraint back down again slightly if necessary (▷ page 92). Make sure that you do not interfere with the correct routing of Top Tether belt (3).

- ▶ Remove the safety net (▷ page 274).
- ▶ Remove luggage compartment cover (▷ page 272).
- ▶ Move the head restraint upwards.
- ▶ Fit the ISOFIX child restraint system with Top Tether. Comply with the manufacturer's installation instructions when doing so.
- ▶ Route Top Tether belt (3) under the head restraint between the two head restraint bars.
- ▶ Attach Top Tether hook (1) to Top Tether anchorage (2) on the luggage compartment floor.
- ▶ Hook Top Tether hook (1) of Top Tether belt (3) into Top Tether anchorage (2).

Make sure that:

- Top Tether hook (1) is hooked into Top Tether anchorage (2) as shown.
  - Top Tether belt (3) is not twisted.
- ▶ Make sure that Top Tether belt (3) is not twisted.

## Problems with automatic child seat recognition

Problem	Possible causes/consequences and ► Solutions
The  PASSENGER AIRBAG OFF indicator lamp on the centre console is lit.	A special Mercedes-Benz child seat with a transponder for automatic child seat recognition has been fitted to the front-passenger seat. The front-passenger front airbag has therefore been disabled as desired.

Problem	Possible causes/consequences and ► Solutions
The  PASSENGER AIRBAG OFF indicator lamp on the centre console is lit. or The  warning lamp lights up and/or the  PASSENGER AIRBAG OFF indicator lamp does not light up briefly when you switch the ignition on.	<p> <b>Risk of injury</b></p> <p>There is no child seat fitted to the front-passenger seat. Automatic child seat recognition is malfunctioning.</p> <p>► Remove electronic equipment from the front-passenger seat, e.g.:</p> <ul style="list-style-type: none"> <li>• laptop</li> <li>• mobile phone</li> <li>• cards with transponders, such as ski passes or access cards</li> </ul> <p>If the  PASSENGER AIRBAG OFF indicator lamp is still lit:</p> <p>► Visit a qualified specialist workshop.</p>

## Suitable positioning of the child restraint systems

- **To fit a child restraint system on the front-passenger seat:** move the front-passenger seat to its rearmost and lowest position and the belt height adjustment to the lowest position.

Key to the letters used in the following table:

- X Seat which is unsuitable for children in this weight category.  
 U Suitable for child restraint systems in the "Universal" category that are approved for use in this weight category.  
 L Suitable for child restraint systems as recommended; see the following table of "Recommended child restraint systems" (> page 56).

### Front-passenger seat

Weight categories	Front-passenger airbag is not disabled:	Front-passenger front airbag is disabled:
Category 0: up to 10 kg	X	L
Group 0+: up to 13 kg	X	L
Category I: 9 to 18 kg	L	U

Weight categories	Front-passenger airbag is not disabled:	Front-passenger front airbag is disabled:
Category II: 15 to 25 kg	L	U
Group III: 22 to 36 kg	L	U

**Vehicles with automatic child seat recognition in the front-passenger seat:** a "Universal" category child restraint system with a transponder for automatic child seat recognition must be fitted when the front-passenger airbag is disabled. The  PASSENGER AIRBAG OFF indicator lamp must be lit.

### Rear seats

Weight categories	Rear seat left, right
Category 0: up to 10 kg	U
Group 0+: up to 13 kg	U
Category I: 9 to 18 kg	U
Category II: 15 to 25 kg	U
Group III: 22 to 36 kg	U

"Universal" category child restraint systems can be recognised by their orange approval label.



Example: approval label on the child restraint system

### Suitability of the rear seats for attaching ISOFIX child restraint systems

Key to the letters used in the following table:

- X ISOFIX position that is not suitable for ISOFIX child restraint systems in this weight category and/or size category.
- IUF Suitable for forward-facing ISOFIX child restraint systems that belong to the "Universal" category which are approved for use in this weight category.
- IL Suitable for ISOFIX child restraint systems as recommended; see the following table of "Recommended child restraint systems" (▷ page 56).

**Carry-cot weight category**

Size category	Equipment	Rear seat, left and right
F	ISO/L1	X
G	ISO/L2	X

**Weight category 0: up to 10 kg, up to approximately 6 months**

Size category	Equipment	Rear seat, left and right
E	ISO/R1	IL

**Weight category 0+: up to 13 kg, up to approximately 15 months**

Size category	Equipment	Rear seat, left and right
E	ISO/R1	IL
D	ISO/R2	IL
C	ISO/R3	IL

**Weight category I: 9 to 18 kg, approximately 9 months to 4 years**

Size category	Equipment	Rear seat, left and right
D	ISO/R2	IL
C	ISO/R3	IL
B	ISO/F2	IUF
B1	ISO/F2X	IUF
A	ISO/F3	IUF

**Recommended child restraint systems****Weight category 0: up to 10 kg, up to approximately 9 months**

<b>Manufacturer</b>	Britax Römer	Britax Römer
<b>Type</b>	BABY SAFE PLUS	BABY SAFE ISOFIX PLUS
<b>Type approval number</b>	E1 03 301146 E1 04 301146	E1 03 301146 E1 04 301146

<b>Order number</b>	A 000 970 10 00	B6 6 86 8224
<b>Automatic child seat recognition</b>	Yes	No The child restraint system may only be fitted to the left-hand or right-hand rear seat.

#### Weight category 0+: up to 13 kg, up to approximately 18 months

<b>Manufacturer</b>	Britax Römer	Britax Römer
<b>Type</b>	BABY SAFE PLUS	BABY SAFE ISOFIX PLUS
<b>Type approval number</b>	E1 03 301146 E1 04 301146	E1 03 301146 E1 04 301146
<b>Order number</b>	A 000 970 10 00	B6 6 86 8224
<b>Automatic child seat recognition</b>	Yes	No The child restraint system may only be fitted to the left-hand or right-hand rear seat.

#### Weight category I: 9 to 18 kg, approximately 8 months to 4 years

<b>Manufacturer</b>	Britax Römer	Britax Römer
<b>Type</b>	DUO PLUS	DUO PLUS
<b>Type approval number</b>	E1 03 301133 E1 04 301133	E1 03 301133 E1 04 301133
<b>Order number</b>	A000 970 11 00	A 000 970 16 00
<b>Automatic child seat recognition</b>	Yes	No For child restraint systems without a transponder, move the front-passenger seat to the rearmost position.

#### Weight category II/III: 15 to 36 kg, approximately 4 to 12 years

<b>Manufacturer</b>	Britax Römer	Britax Römer
<b>Type</b>	KID	KID
<b>Type approval number</b>	E1 03 301148 E1 04 301148	E1 03 301148 E1 04 301148

<b>Order number</b>	A 000 970 12 00	A 000 970 17 00
<b>Automatic child seat recognition</b>	Yes	No For child restraint systems without a transponder, move the front-passenger seat to the rearmost position.

### Suggested "Universal" category ISOFIX child restraint systems:

#### Carry-cot weight category

<b>Size categories</b>	F, G
<b>Manufacturer</b>	-
<b>Type</b>	-
<b>Approval number (E1 ...)</b>	-
<b>Order number</b>	-
<b>Automatic child seat recognition</b>	-

#### Category 0: up to 10 kg

<b>Size category</b>	E
<b>Manufacturer</b>	-
<b>Type</b>	-
<b>Approval number (E1 ...)</b>	-
<b>Order number</b>	-
<b>Automatic child seat recognition</b>	-

#### Group 0+: up to 13 kg

<b>Size categories</b>	E	D, C
<b>Manufacturer</b>	Britax Römer	-
<b>Type</b>	BABY SAFE ISOFIX PLUS	-
<b>Approval number (E1 ...)</b>	04 301146	-
<b>Order number</b>	B6 6 86 8224	-
<b>Automatic child seat recognition</b>	No	-

## Category I: 9 to 18 kg

<b>Size categories</b>	D, C, B, A
<b>Manufacturer</b>	–
<b>Type</b>	–
<b>Approval number (E1 ...)</b>	–
<b>Order number</b>	–
<b>Automatic child seat recognition</b>	–

<b>Size category</b>	B1
<b>Manufacturer</b>	Britax Römer
<b>Type</b>	DUO PLUS
<b>Approval number (E1 ...)</b>	03 301133 04 301133
<b>Order number</b>	A000 970 11 00
<b>Automatic child seat recognition</b>	Yes

## Child-proof locks

## Important safety notes

 **WARNING**

Activate the child-proof locks for the rear doors and the override switch for the rear windows when children are travelling in the vehicle. Otherwise, the children could open doors or side windows while the vehicle is in motion and injure themselves or others.

 **WARNING**

Do not leave children unsupervised in the vehicle, even if they are secured in a child restraint system. They could injure themselves on parts of the vehicle. They could also be seriously or even fatally injured by prolonged exposure to extreme heat or cold.

Do not expose the child restraint system to direct sunlight. Parts of the child restraint system could heat up and the child could burn herself/himself on them.

If a child opens a door, the child or other persons could be injured as a result. They could get out and injure themselves or be injured by a passing vehicle.

**Child-proof locks for the rear doors**

You secure each door individually with the child-proof locks on the rear doors. A door secured with a child-proof lock cannot be opened from inside the vehicle. When the vehicle is unlocked, the door can be opened from the outside.



- ▶ **To activate:** press the child-proof lock lever down in the direction of arrow ②.
- ▶ Make sure that the child-proof locks are working properly.
- ▶ **To deactivate:** press the child-proof lock lever up in the direction of arrow ①.

### Override feature for the rear side windows

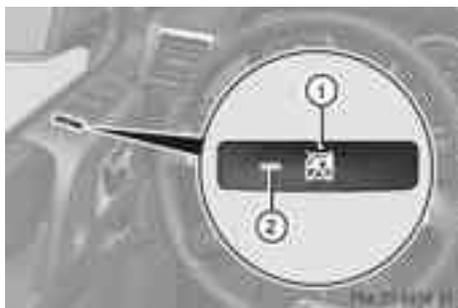

- ▶ **To activate/deactivate:** press button ①. If indicator lamp ② is lit, operation of the rear side windows is disabled. Operation is only possible using the switches in the driver's door. If indicator lamp ② is off, operation is possible using the switches in the rear compartment.

## Driving safety systems

### Driving safety systems overview

In this section, you will find information about the following driving safety systems:

- ABS (**A**nti-**l**ock **B**raking **S**ystem) (▷ page 60)
- BAS (**B**rake **A**ssist **S**ystem) (▷ page 61)
- Adaptive brake lamps (▷ page 61)
- ESP® (**E**lectronic **S**tability **P**rogram) (▷ page 62)
- EBD (**e**lectronic **b**rake **f**orce **d**istribution) (▷ page 64)
- ADAPTIVE BRAKE (▷ page 64)
- Trailer stabilisation

### Important safety notes

If you fail to adapt your driving style, the driving safety systems can neither reduce the risk of accident nor override the laws of physics. Driving safety systems are merely aids designed to assist driving. You are responsible for the distance to the vehicle in front, for vehicle speed and for braking in good time. Always adapt your driving style to suit the prevailing road and weather conditions as well as the traffic conditions, and maintain a safe distance from the vehicle in front. Drive carefully.

- ❗ Please note that the driving safety systems described only work as effectively as possible when there is adequate contact between the tyres and the road surface. Pay particular attention to the information regarding tyres, recommended minimum tyre tread depths etc. in the "Wheels and tyres" section (▷ page 318).

In wintry driving conditions, always use winter tyres (M+S tyres) and, if necessary, snow chains. Only in this way will the driving safety systems described in this section work as effectively as possible.

### ABS (Anti-lock Braking System)

#### Important safety notes

- ❗ Observe the "Important safety notes" section (▷ page 60).

**⚠ WARNING**

If ABS is faulty, the wheels could lock when braking. The steerability and braking characteristics may be severely impaired. Additionally, further driving safety systems are deactivated. There is an increased danger of skidding and accidents.

Drive on carefully. Have ABS checked immediately at a qualified specialist workshop.

If ABS is malfunctioning, other systems, including driving safety systems, will also become inoperative. Observe the information on the ABS warning lamp (▷ page 254) and any display messages that may appear in the instrument cluster (▷ page 229).

ABS regulates brake pressure in such a way that the wheels do not lock when you brake. This allows you to continue steering the vehicle when braking.

ABS works from a speed of about 8 km/h upwards, regardless of road-surface conditions. ABS works on slippery surfaces, even when you only brake gently.

The yellow  ABS warning lamp in the instrument cluster lights up when the ignition is switched on. It goes out when the engine is running.

**Brakes**

If ABS intervenes when braking, you will feel a pulsing in the brake pedal.

► **If ABS intervenes:** continue to depress the brake pedal with force until the braking situation is over.

► **To make a full brake application:** depress the brake pedal with full force.

The pulsating brake pedal can be an indication of hazardous road conditions, and functions as a reminder to take extra care while driving.

**Off-road ABS**

If the **LOW RANGE** shift range is selected by the transfer case, (▷ page 202), an ABS system specifically suited to off-road terrain is automatically activated.

At speeds below 60 km/h, the front wheels lock cyclically during braking. The digging-in effect achieved in the process reduces the stopping distance when driving off-road. This limits steering capability.

**BAS (Brake Assist System)**

**i** Observe the "Important safety notes" section (▷ page 60).

**⚠ WARNING**

If BAS is malfunctioning, the braking distance in an emergency braking situation is increased. There is a risk of accident.

In an emergency braking situation, depress the brake pedal with full force. ABS prevents the wheels from locking.

BAS operates in emergency braking situations. If you depress the brake pedal quickly, BAS automatically boosts the braking force, thus shortening the stopping distance.

► Keep the brake pedal depressed firmly until the emergency braking situation is over. ABS prevents the wheels from locking.

The brakes will function as usual once you release the brake pedal. BAS is deactivated.

**Adaptive brake lamps**

If you brake sharply from a speed of more than 50 km/h or if braking is assisted by BAS, the brake lamps flash rapidly. In this way, traffic travelling behind you is warned in an even more noticeable manner.

If you brake sharply from a speed of more than 70 km/h to a standstill, the hazard warning lamps are activated automatically. If the brakes are applied again, the brake lamps

light up continuously. The hazard warning lamps switch off automatically if you travel faster than 10 km/h. You can also switch off the hazard warning lamps using the hazard warning switch button (▷ page 109).

## ESP® (Electronic Stability Program)

### Important safety notes

- i** Observe the "Important safety notes" section (▷ page 60).

#### WARNING

If ESP® is malfunctioning, ESP® is unable to stabilise the vehicle. In addition, other driving safety systems are switched off. This increases the risk of skidding and an accident.

Drive on carefully. Have ESP® checked at a qualified specialist workshop.

- !** Only operate the vehicle for a maximum of ten seconds on a brake dynamometer. Switch off the ignition.

Application of the brakes by ESP® may otherwise destroy the brake system.

- !** A function or performance test should only be carried out on a twin-axle dynamometer. Before you operate the vehicle on such a dynamometer, please consult a qualified workshop. You could otherwise damage the drive train or the brake system.

ESP® monitors driving stability and traction. Traction is the transmission of power from the tyres to the road surface.

ESP® is deactivated if the  warning lamp in the instrument cluster lights up continuously when the engine is running.

If the  warning lamp and the  warning lamp are lit continuously, ESP® is not available due to a malfunction.

Observe the information on warning lamps (▷ page 256) and any display messages that appear in the instrument cluster (▷ page 229).

If ESP® detects that the vehicle is deviating from the direction desired by the driver, one or more wheels are braked to stabilise the vehicle. If necessary, the engine output is also modified to keep the vehicle on the desired course within physical limits. ESP® assists the driver when pulling away on wet or slippery roads. ESP® can also stabilise the vehicle during braking.

If ESP® intervenes, the  warning lamp flashes in the instrument cluster.

If ESP® intervenes:

- ▶ Do not deactivate ESP® under any circumstances.
- ▶ When pulling away, only depress the accelerator pedal as far as is necessary.
- ▶ Adapt your driving style to suit the prevailing road and weather conditions.

- i** Only use wheels with the recommended tyre sizes. Only then will ESP® function properly.

- i** If differential locks are switched on, ABS, BAS and ESP® switch off automatically.

## 4ETS (Electronic Traction System)

Traction control remains active if you deactivate ESP®.

- ▶ If appropriate for the driving conditions, engage the **LOW RANGE** off-road gear (▷ page 202).

Traction control is part of ESP®.

Traction control brakes the drive wheels individually if they spin. This enables you to pull away and accelerate on slippery surfaces, for example if the road surface is slippery on one side. In addition, more drive torque is transferred to the wheel or wheels with traction.

Traction control remains active if you deactivate ESP®.

Traction control is no longer active above a speed of about 60 km/h.

Traction control brakes the drive wheels individually if they spin. This enables you to pull away and accelerate on slippery surfaces, for example if the road surface is slippery on one side. In addition, more drive torque is transferred to the wheel or wheels with traction.

### Deactivating/activating ESP®

#### WARNING

If you deactivate ESP®, ESP® no longer stabilises the vehicle. There is an increased risk of skidding and an accident.

Only deactivate ESP® in the situations described in the following.



► **To deactivate:** press button  until the  warning lamp lights up in the instrument cluster.

► **To activate:** press button  until the  warning lamp goes out in the instrument cluster.

ESP® is activated automatically when the engine is started.

**i Vehicles with the ECO start/stop function:** the ECO start/stop function automatically switches the engine off when the vehicle comes to a stop. When pulling away again, the engine starts automatically. ESP® remains in its previously selected status. Example: if ESP® was deactivated before the engine was switched off, ESP® remains deactivated when the engine is switched on again.

It may be best to deactivate ESP® in the following situations:

- when using snow chains
- in deep snow
- on sand or gravel

If you deactivate ESP®:

- ESP® no longer improves driving stability.
- the engine's torque is no longer limited, and the drive wheels can spin. The spinning of the wheels results in a cutting action, which provides better grip.
- traction control is still activated.
- ESP® still provides support if you brake.
- and are driving at above 60 km/h, ESP® still intervenes when one wheel reaches its grip limit even though it is switched off.

**i** If ESP® is deactivated and one or more wheels start to spin, the  warning lamp in the instrument cluster flashes. In such situations, ESP® will not stabilise the vehicle.

### Trailer stabilisation

#### WARNING

If road and weather conditions are poor, trailer stabilisation will not be able to prevent the vehicle/trailer combination from swerving. Trailers with a high centre of gravity can tip over before ESP® can detect this. There is a risk of an accident.

Always adapt your driving style to the prevailing road and weather conditions.

Trailer stabilisation does not work if ESP® is deactivated or disabled because of a malfunction.

If your vehicle/trailer combination begins to lurch, you can only stabilise the vehicle/trailer combination by depressing the brake firmly.

In this situation, ESP® assists you and can detect if the vehicle/trailer combination begins to lurch. ESP® slows the vehicle down

by braking and limiting the engine output until the vehicle/trailer combination has stabilised.

Trailer stabilisation is active above speeds of about 60 km/h.

### EBD (electronic brake force distribution)

- Observe the "Important safety notes" section (▷ page 60).

#### WARNING

If EBD has malfunctioned, the rear wheels can still lock, e.g. under full braking. This increases the risk of skidding and an accident.

You should therefore adapt your driving style to the different handling characteristics. Have the brake system checked at a qualified specialist workshop.

Observe information regarding indicator and warning lamps (▷ page 254) as well as display messages (▷ page 231).

EBD monitors and controls the brake pressure on the rear wheels to improve driving stability while braking.

### ADAPTIVE BRAKE

ADAPTIVE BRAKE provides increased braking safety. In addition to the braking function, ADAPTIVE BRAKE also has the HOLD function (▷ page 196) and hill start assist (▷ page 145).

## Anti-theft systems

### Immobiliser

- To activate:** remove the key from the ignition lock.
- To deactivate:** switch on the ignition.

The immobiliser prevents your vehicle from being started without the correct key.

- The immobiliser is always deactivated when you start the engine.

### ATA (Anti-Theft Alarm system)



- To prime:** lock the vehicle with the key. Indicator lamp  flashes. The alarm system is primed after approximately 15 seconds.
- To deactivate:** unlock the vehicle with the key.
- If you then do not open a door or the rear door, the alarm system switches back on again after approximately 40 seconds.
- To stop the alarm:** insert the key into the ignition lock.

The alarm is switched off.

or

- Press the  or  button on the key. The alarm is switched off.

A visual and audible alarm is triggered if the alarm system is primed and you open:

- a door
- a door using the emergency key element
- the rear door/tailgate
- the bonnet

The alarm is also triggered if:

- the position of the vehicle is changed
- a window is smashed

The alarm is not switched off, even if you close the open door that has triggered it, for example.

## Tow-away protection

### Function

An audible and visual alarm is triggered if your vehicle's angle of inclination is altered while tow-away protection is primed. This occurs if the vehicle is jacked up on one side, for example.

### Activating

- ▶ **To prime:** lock the vehicle with the key. Tow-away protection is primed after approximately 30 seconds.

### Switching off

- ▶ **To deactivate:** unlock the vehicle with the key. Tow-away protection is switched off automatically.

**i** To prevent a false alarm, deactivate tow-away protection manually if your vehicle:

- is being transported
- is being loaded onto a ferry or car transporter, for example
- is parked on a movable surface, e.g. in a split-level garage

### Deactivating



- ▶ Remove the key from the ignition lock.
- ▶ Press button ①. Indicator lamp ② lights up briefly.
- ▶ Lock the vehicle with the key. Tow-away protection remains deactivated until the vehicle is unlocked and locked again.

## Interior motion sensor

### Function

When the interior motion sensor is primed, a visual and audible alarm is triggered if movement is detected in the vehicle interior. This can occur if someone reaches into the vehicle interior, for example.

### Activating

- ▶ Make sure that:
  - the side windows are closed.
  - the sliding sunroof is closed.
  - there are no objects, e.g. mascots, hanging on the rear-view mirror or on the grab handles on the roof trim. This will prevent false alarms.
- ▶ Lock the vehicle with the key. The interior motion sensor is primed after approximately 30 seconds.

### Switching off

- ▶ Unlock the vehicle with the key. The interior motion sensor is switched off automatically.
- i** To prevent a false alarm, deactivate the interior motion sensor if you lock your vehicle and:
  - people or animals remain in the vehicle.
  - the side windows remain open.
  - the sliding sunroof remains open.

## Deactivating



- ▶ Remove the key from the ignition lock.
- ▶ Press button ①.  
Indicator lamp ② lights up briefly.
- ▶ Lock the vehicle with the key.  
The interior motion sensor remains deactivated until the vehicle is unlocked and locked again.

Useful information .....	68
Key .....	68
Doors .....	73
Rear door (G-Class long-wheelbase version) .....	75
Tailgate (G-Class Cabriolet) .....	76
Side windows .....	77
Sliding sunroof .....	79
Soft top (G-Class Cabriolet) .....	81

## Useful information

- i** This Owner's Manual describes all models, series and optional equipment for your vehicle that were available at the time of going to press. Country-specific differences are possible. Note that your vehicle may not be fitted with all features described. This is also the case for systems and functions relevant to safety.
- i** Read the information on qualified specialist workshops: (▷ page 22).

## Key

### Important safety notes

#### WARNING

If children are left unsupervised in the vehicle, they could:

- open the doors, thus endangering other people or road users.
- get out and disrupt traffic.
- operate the vehicle's equipment.

Additionally, children could set the vehicle in motion if, for example, they:

- release the parking brake.
- shift the automatic transmission out of parking position P.
- shift the manual transmission into neutral.
- start the engine.

There is a risk of an accident and injury.

When leaving the vehicle, always take the key with you and lock the vehicle. Never leave children or animals unattended in the vehicle. Always keep the key out of reach of children.

#### WARNING

Do not transport any heavy or hard objects in the vehicle interior or in the load compartment if these are not properly secured.

Loads which are not secured or not stored properly increase the risk of children being injured in the following circumstances:

- strong braking manoeuvres
- sudden changes of direction
- in the event of an accident

#### WARNING

If you attach heavy or large objects to the key, the key could be unintentionally turned in the ignition lock. This could cause the engine to be switched off. There is a risk of an accident.

Do not attach any heavy or large objects to the key. Remove any bulky keyrings before inserting the key into the ignition lock.

## Key functions

#### WARNING

If children are left unsupervised in the vehicle, they could:

- open the doors, thus endangering other people or road users.
- get out and disrupt traffic.
- operate the vehicle's equipment.

Additionally, children could set the vehicle in motion if, for example, they:

- release the parking brake.
- shift the automatic transmission out of parking position P.
- shift the manual transmission into neutral.
- start the engine.

There is a risk of an accident and injury.

When leaving the vehicle, always take the key with you and lock the vehicle. Never leave children or animals unattended in the vehicle. Always keep the key out of reach of children.

#### WARNING

If you attach heavy or large objects to the key, the key could be unintentionally turned in the ignition lock. This could cause the engine to be switched off. There is a risk of an accident.

Do not attach any heavy or large objects to the key. Remove any bulky keyrings before inserting the key into the ignition lock.

### WARNING

When the double locks are activated, the doors can no longer be opened from the inside. People in the vehicle can no longer get out, e.g. in hazardous situations. There is a risk of injury.

Therefore, do not leave any people unsupervised in the vehicle, particularly children, elderly people or people in need of special assistance. Do not activate the double lock when people are in the vehicle.

### Deactivating the double lock

- i** If the vehicle has been locked with the key, the double lock function is activated as standard. It is then not possible to open the doors from inside the vehicle.
- ▶ Deactivate the interior motion sensor (▷ page 65).
- ▶ Lock the vehicle with the key. The double lock is deactivated and the doors can be opened from the inside.



- ①  To lock the vehicle
- ②  To unlock the vehicle

- ▶ **To unlock centrally:** press the  button.

If you do not open the vehicle within approximately 40 seconds of unlocking:

- the vehicle is locked again.
- the anti-theft system is primed again.

- ▶ **To lock centrally:** press the  button.

The key centrally locks/unlocks:

- the doors
- the rear door
- the fuel filler flap

- i** When unlocking, the turn signals flash once. When locking, they flash three times.

You can also set an audible signal to confirm that the vehicle has been locked. The audible signal can be activated and deactivated using the on-board computer (▷ page 223).

When it is dark, the surround lighting also comes on if it is activated in the on-board computer (▷ page 222).

### Changing the settings of the locking system



You can change the setting of the locking system in such a way that only the driver's door and the fuel filler flap are unlocked. This is useful if you frequently travel on your own.

- i** If the setting of the locking system is changed within the signal range of the vehicle, pressing the  or  button locks or unlocks the vehicle.

- ▶ **To change the setting:** press and hold down the  and  buttons simulta-

neously for approximately six seconds until battery check lamp ① flashes twice.

The key now functions as follows:

- ▶ **To unlock the driver's door and fuel filler flap:** press the  button once.
- ▶ **To unlock centrally:** press the  button twice.
- ▶ **To lock centrally:** press the  button.

### Restoring factory settings



- ▶ Press the  and  buttons simultaneously for approximately six seconds until battery check lamp ① flashes twice.

### Emergency key element

#### General notes

If the vehicle can no longer be unlocked with the key, use the emergency key element.

If you use the emergency key element to unlock and open the driver's door, the anti-theft alarm system will be triggered (▷ page 64).

There are several ways to turn off the alarm:

- ▶ Press the  or  button on the key.
- or
- ▶ Insert the key into the ignition lock.

If you unlock the vehicle using the emergency key element, the fuel filler flap will not be unlocked automatically.

- ▶ **To unlock the fuel filler flap:** insert the key into the ignition lock.

### Removing the emergency key element



- ① Release catch
- ② Emergency key element
- ▶ Push release catch ① in the direction of the arrow and at the same time, remove emergency key element ② from the key.

### Battery of the key

#### Important safety notes

##### WARNING

Batteries contain toxic and corrosive substances. If batteries are swallowed, it can result in severe health problems. There is a risk of fatal injury.

Keep batteries out of the reach of children. If a battery is swallowed, seek medical attention immediately.

##### Environmental note



Batteries contain pollutants. It is illegal to dispose of them with the household rubbish. They must be collected separately and disposed of in an environmentally responsible recycling system.



Dispose of batteries in an environmentally responsible manner. Take discharged

batteries to a qualified specialist workshop or to a collection point for used batteries.

Mercedes-Benz recommends that you have the batteries replaced at a qualified specialist workshop.

### Checking the battery



- ▶ Press the  or  button.

The battery is working properly if battery check lamp ① lights up briefly.

If battery check lamp ① does not light up during the test, the battery is discharged.

- ▶ Change the battery (▶ page 71).

**i** You can get a battery in any qualified specialist workshop.

**i** Have the batteries replaced at a qualified specialist workshop.

**i** If the key battery is checked within the signal reception range of the vehicle, pressing the  or  button:

- locks or
- unlocks the vehicle

### Replacing the battery

You require a CR 2025 3 V cell battery.

- ▶ Take the emergency key element out of the key (▶ page 70).



① Battery compartment cover

② Emergency key element

- ▶ Press emergency key element ② into the opening in the key in the direction of the arrow until battery tray cover ① opens. Do not hold the cover closed while doing so.
- ▶ Remove battery tray cover ①.



③ Battery

- ▶ Repeatedly tap the key against your palm until battery ③ falls out.

▶ Insert the new battery with the positive terminal facing upwards. Use a lint-free cloth to do so.

▶ Make sure that the surface of the battery is free from lint, grease and all other forms of contamination.

▶ Insert the front tabs of battery tray cover ① and then press to close it.

▶ Insert the emergency key element into the key.

▶ Check the function of all key buttons on the vehicle.

## Problems with the key

Problem	Possible causes/consequences and ► Solutions
You cannot lock or unlock the vehicle using the key.	<p>The key battery is discharged or nearly discharged.</p> <ul style="list-style-type: none"> <li>► Point the tip of the key at the driver's door handle from a distance of approximately 50 cm and try to unlock or lock the vehicle again.</li> </ul> <p>If this does not work:</p> <ul style="list-style-type: none"> <li>► Check the key battery (▷ page 71) and replace it if necessary (▷ page 71).</li> <li>► Lock (▷ page 74) or unlock (▷ page 75) the vehicle using the emergency key element.</li> </ul> <p>The key is faulty.</p> <ul style="list-style-type: none"> <li>► Lock or unlock the vehicle using the emergency key element (▷ page 74).</li> <li>► Have the key checked at a qualified specialist workshop.</li> </ul>
You have lost a key.	<ul style="list-style-type: none"> <li>► Have the key deactivated at a qualified specialist workshop.</li> <li>► Report the loss immediately to the vehicle insurers.</li> <li>► If necessary, have the locks replaced as well.</li> </ul>
You have lost the emergency key element.	<ul style="list-style-type: none"> <li>► Report the loss immediately to the vehicle insurers.</li> <li>► If necessary, have the locks replaced as well.</li> </ul>

Problem	Possible causes/consequences and ► Solutions
The engine cannot be started using the key.	<p>The key has been in position <b>0</b> (▷ page 143) for a considerable time.</p> <ul style="list-style-type: none"> <li>► Remove the key and reinsert it into the ignition lock.</li> <li>► Start the engine.</li> </ul> <p>The on-board voltage is too low.</p> <ul style="list-style-type: none"> <li>► Switch off non-essential consumers, e.g. seat heating or interior lighting, and try to turn the key again.</li> </ul> <p>If this does not work:</p> <ul style="list-style-type: none"> <li>► Check the battery and charge it if necessary (▷ page 307).</li> </ul> <p>or</p> <ul style="list-style-type: none"> <li>► Jump-start the vehicle (▷ page 309).</li> </ul> <p>or</p> <ul style="list-style-type: none"> <li>► Consult a qualified specialist workshop.</li> </ul>

## Doors

## Important safety notes

**⚠ WARNING**

If children are left unsupervised in the vehicle, they could:

- open the doors, thus endangering other people or road users.
- get out and disrupt traffic.
- operate the vehicle's equipment.

Additionally, children could set the vehicle in motion if, for example, they:

- release the parking brake.
- shift the automatic transmission out of parking position P.
- shift the manual transmission into neutral.
- start the engine.

There is a risk of an accident and injury.

When leaving the vehicle, always take the key with you and lock the vehicle. Never leave children or animals unattended in the vehicle. Always keep the key out of reach of children.

**Unlocking and opening the doors from the inside**

You can open a door anytime from inside the vehicle, even if it has been locked, unless the child-proof locks (▷ page 59) have been activated.

If the vehicle has previously been locked with the key, opening a door from the inside will trigger the anti-theft alarm system. Switch off the alarm (▷ page 64).

You can only open the rear compartment doors from inside the vehicle if they are not secured by the child-proof locks (▷ page 59).



- ▶ Pull door handle ②.

If the door is locked, locking knob ① pops up. The door is unlocked and can be opened.

**Centrally locking and unlocking the vehicle from the inside****⚠ WARNING**

If children are left unsupervised in the vehicle, they could:

- open the doors, thus endangering other people or road users.
- get out and disrupt traffic.
- operate the vehicle's equipment.

Additionally, children could set the vehicle in motion if, for example, they:

- release the parking brake.
- shift the automatic transmission out of parking position P.
- shift the manual transmission into neutral.
- start the engine.

There is a risk of an accident and injury.

When leaving the vehicle, always take the key with you and lock the vehicle. Never leave children or animals unattended in the vehicle. Always keep the key out of reach of children.

You can centrally lock or unlock the vehicle from the inside. This feature may be useful if, for example, you wish to unlock the front-passenger door from the inside or lock the vehicle before you pull away.

The central locking button does not lock or unlock the fuel filler flap.



► **To unlock:** press button ①.

► **To lock:** press button ②.

**i** You cannot unlock the vehicle centrally from the inside if the vehicle has been locked from the outside using the key.

**i** It is only possible to lock the vehicle centrally if all doors are closed.

### Automatic locking feature

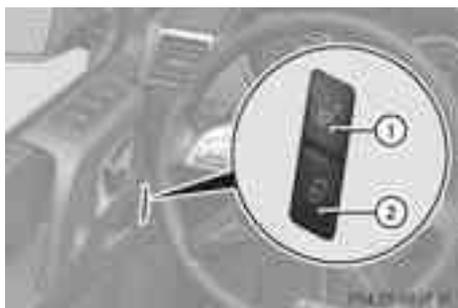

① To switch off

② To activate

► **To deactivate:** press and hold button ① for about five seconds until a tone sounds.

► **To activate:** press and hold button ② for about five seconds until a tone sounds.

**i** If you press one of the two buttons and do not hear a tone, the relevant setting has already been selected.

The vehicle is locked automatically when the ignition is switched on and the wheels are turning.

You could therefore be locked out if:

- the vehicle is being pushed.
- the vehicle is being towed.
- the vehicle is being tested on a dynamometer.

You can also switch the automatic locking function on and off using the on-board computer (► page 223).

### Unlocking the driver's door (emergency key element)

If the vehicle can no longer be centrally unlocked with the key, use the emergency key element.

If you use the emergency key element to unlock and open the driver's door, the anti-theft alarm system will be triggered (► page 64).

Take the emergency key element out of the key (► page 70).



► Insert the emergency key element into the lock of the driver's door as far as it will go.

► Turn the emergency key element anti-clockwise to position 1. The door is unlocked.

**i** On right-hand-drive vehicles, turn the emergency key element clockwise.

- ▶ Turn the emergency key element back and remove it.
- ▶ Insert the emergency key element into the key.

### Locking the vehicle

If the vehicle can no longer be centrally locked with the key, use the emergency key element.

- ▶ Close the front-passenger door, the rear compartment doors and the rear door or tailgate (G-Class Cabriolet).
- ▶ Press the locking button (▷ page 73).
- ▶ Make sure that the locking knobs on the doors are still visible. Press down the locking knobs by hand, if necessary.
- ▶ Close the driver's door from the outside.



- ▶ Take the emergency key element out of the key (▷ page 70).
- ▶ Insert the emergency key element into the lock of the driver's door as far as it will go.
- ▶ Turn the emergency key element clockwise as far as it will go to position **1**.
- i** On right-hand-drive vehicles, turn the emergency key element anti-clockwise.
- ▶ Turn the emergency key element back and remove it.
- ▶ Check if the doors, including the rear door or tailgate (G-Class Cabriolet), are locked.
- ▶ Insert the emergency key element into the key.

### Rear door (G-Class long-wheelbase version)

#### Important safety notes

#### WARNING

Combustion engines emit poisonous exhaust gases such as carbon monoxide. If the tailgate/rear door is open when the engine is running, particularly if the vehicle is moving, exhaust fumes could enter the passenger compartment. There is a risk of poisoning.

Turn off the engine before opening the tailgate/rear door. Never drive off with the tailgate/rear door open.

**!** The tailgate swings out to the side when opened. Therefore, make sure that there is sufficient clearance.

**i** Do not leave the key in the luggage compartment. You may otherwise be inadvertently locked out.

#### Opening

You can only open the rear door after unlocking it first.

- ▶ Press the  button on the key.



- ▶ Press release button **1** and pull door handle **2**.
- ▶ Open the rear door.

**Closing**

- ▶ Push the rear door closed from outside the vehicle.
- ▶ If necessary, lock the vehicle with the  button on the key.

**Tailgate (G-Class Cabriolet)****Important safety notes****⚠ WARNING**

Combustion engines emit poisonous exhaust gases such as carbon monoxide. If the tailgate is open when the engine is running, particularly if the vehicle is moving, exhaust fumes could enter the passenger compartment. There is a risk of poisoning.

Turn off the engine before opening the tailgate. Never drive with the tailgate open.

**⚠ WARNING**

If the spare wheel bracket is not correctly closed and engaged, it could swing to the side while the vehicle is in motion. There is a risk of an accident and injury.

Close the spare wheel bracket completely before the journey and make sure that it is engaged.

**Opening**

- ❗ Make sure that there is sufficient clearance.

You can only open the tailgate after it has been unlocked.

- ▶ Press the  button on the key. The tailgate is unlocked.

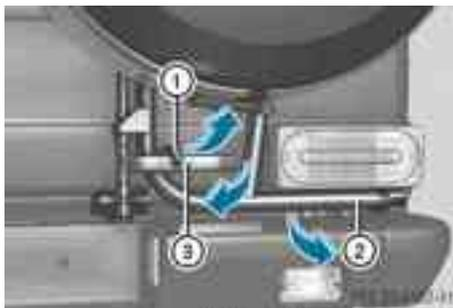

- ▶ Raise safety catch ① and pull lever ③ in the direction of the arrow.
- ▶ Swing spare wheel bracket ② to the side in the direction of the arrow.

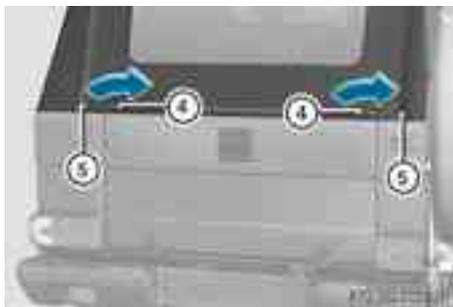

- ▶ Turn quick-locking mechanisms ④ clockwise.
- ▶ Open zips ⑤ upwards approximately 10 cm.

- ⓘ When the soft top is open and the tonneau cover is attached, you need only release the quick-locking mechanisms on the tonneau cover.



- ▶ Pull handle ⑥ upwards and push down the tailgate.

### Closing

- ▶ Fold the tailgate upwards.  
The tailgate engages audibly.
- ▶ If necessary, lock the vehicle with the  button on the key.
- ▶ Zip up the tonneau cover.
- ▶ Turn the quick-release fasteners to the left.
- ▶ Swing the spare wheel bracket to the left until it sits on the tailgate.
- ▶ Press the lever to the right until the retaining hook engages audibly.

### Side windows

#### Important safety notes

#### WARNING

While opening the side windows, body parts could become trapped between the side window and the door frame as the side window moves. There is a risk of injury.

Make sure that nobody touches the side window during the opening procedure. If somebody becomes trapped, release the switch or pull the switch to close the side window again.

#### WARNING

While opening the side windows, body parts in the closing area could become trapped. There is a risk of injury.

Make sure that no body parts are in close proximity during the closing procedure. If somebody becomes trapped, release the switch or press the switch to open the side window again.

#### WARNING

If children operate the side windows they could become trapped, particularly if they are left unsupervised. There is a risk of injury.

Activate the override feature for the rear side windows. When leaving the vehicle, always take the key with you and lock the vehicle. Never leave children unattended in the vehicle.

#### WARNING

If children are left unsupervised in the vehicle, they could:

- open the doors, thus endangering other people or road users.
- get out and disrupt traffic.
- operate the vehicle's equipment.

Additionally, children could set the vehicle in motion if, for example, they:

- release the parking brake.
- shift the automatic transmission out of parking position P.
- shift the manual transmission into neutral.
- start the engine.

There is a risk of an accident and injury.

When leaving the vehicle, always take the key with you and lock the vehicle. Never leave children or animals unattended in the vehicle. Always keep the key out of reach of children.

#### Opening and closing the side windows

The switches for all side windows are located on the driver's door. There is also a switch on each door for the corresponding side window. The switches on the driver's door take precedence.

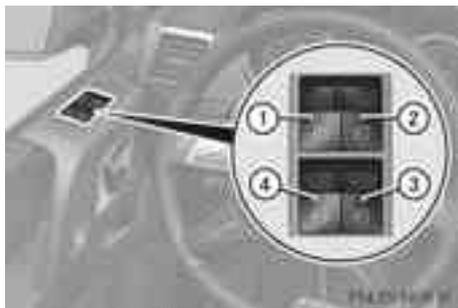

Example: G-Class long-wheelbase version

- ① Front left
- ② Front right
- ③ Rear right (G-Class long-wheelbase version only)
- ④ Rear left (G-Class long-wheelbase version only)

- ▶ Turn the key to position **1** or **2** in the ignition.
- ▶ **To open:** press the corresponding switch.
- ▶ **To close:** pull the corresponding switch.
- ▶ **To open automatically:** press the corresponding switch briefly beyond the point of resistance.  
The side window opens completely.
- ▶ **To interrupt automatic operation:** press or pull the corresponding switch again.
- i** You can continue to operate the side windows after switching off the engine or removing the key. This function remains active for five minutes or until the driver's or front-passenger door is opened.
- i** The side windows cannot be operated from the rear when the override feature for the side windows is activated (▷ page 60).

### Convenience opening feature

- i** The convenience opening feature can only be operated using the key. The key must be close to the driver's door handle.

You can ventilate the vehicle before you start driving. To do this, the key is used to carry out the following functions simultaneously:

- unlock the vehicle
  - open the side windows
  - open the sliding sunroof
  - switch on the seat ventilation for the driver's seat and front-passenger seat
- ▶ Point the tip of the key at the driver's door handle.
  - ▶ Press and hold the  button until the side windows and the sliding sunroof are in the desired position.
  - ▶ **To interrupt convenience opening:** release the  button.

### Problems with the side windows

#### **WARNING**

Closing the side windows with increased force or without the anti-entrapment feature could lead to serious or even fatal injury. Make sure that nobody can become trapped when closing the side windows.

**Problem: a side window cannot be closed because objects are trapped between the side window and the door frame.**

- ▶ Remove the objects.
- ▶ Close the side window.

**Problem: a side window cannot be closed and you cannot see the cause.**

If a side window is obstructed during closing and reopens again slightly:

- ▶ Immediately after the window blocks, pull the corresponding switch again until the side window has closed.

If a side window is obstructed again during closing and reopens again slightly:

- ▶ Immediately after the window blocks, pull the corresponding switch again until the side window has closed.
- ❗ If a side window no longer opens or closes due to a malfunction, contact a qualified specialist workshop.

## Sliding sunroof

### Important safety notes

#### ⚠ WARNING

While opening and closing the sliding sunroof, body parts in close proximity could become trapped. There is a risk of injury.

Make sure that no body parts are in close proximity during the opening and closing procedures.

If somebody becomes trapped:

- release the switch immediately, or
- during automatic operation, push the switch briefly in any direction

The opening or closing procedure will be stopped.

#### ⚠ WARNING

If children operate the sliding sunroof they could become trapped, particularly if they are left unsupervised. There is a risk of injury.

When leaving the vehicle, always take the key with you and lock the vehicle. Never leave children unattended in the vehicle.

- ❗ Only open the panorama sliding sunroof if it is free of snow and ice. Otherwise, malfunctions may occur.

Do not allow anything to protrude from the sliding sunroof. Otherwise, the seals could be damaged.

- ❗ Resonance noises can occur in addition to the usual airflow noises when the sliding sunroof is open. They are caused by minor pressure fluctuations in the vehicle interior.

Change the position of the sliding sunroof or open a side window slightly to reduce or eliminate these noises.

### Opening and closing the sliding sunroof



Overhead control panel

- ① To raise
- ② To open
- ③ To close/lower

- ▶ Turn the key to position **1** or **2** (▷ page 143) in the ignition.
- ▶ Press or pull the  switch in the corresponding direction.
- ▶ **To open automatically:** press the  switch briefly beyond the point of resistance in the direction of arrow ②. The sliding sunroof opens completely.
- ▶ **To interrupt automatic operation:** press or pull the  switch again.
- ❗ The automatic operation is only available for opening.

### Operating the sliding sunroof manually

The actuator is located in the luggage compartment, on the left-hand side behind the rear wall trim.

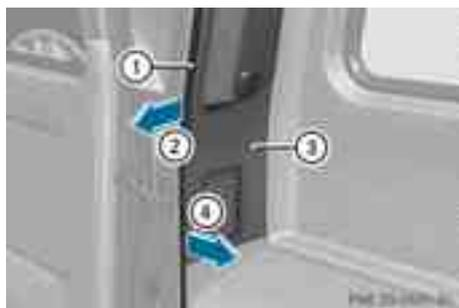

- ▶ Open the rear door.
- ▶ Pull off edge protection ① from the door pillar in the direction of arrow ②.
- ▶ Pull away rear panel trim ③ as far as necessary in the direction of arrow ④ until the electrical connections can be accessed.
- ▶ Disconnect the electrical connections.
- ▶ Remove rear panel trim ③ completely.



- ▶ Take wheel wrench ⑤ out of the vehicle tool kit (▷ page 302).
- ▶ Place wheel wrench ⑤ onto the hexagonal nut of the actuator.
- ▶ **To open:** turn wheel wrench ⑤ anti-clockwise.
- ▶ **To close:** turn wheel wrench ⑤ clockwise.

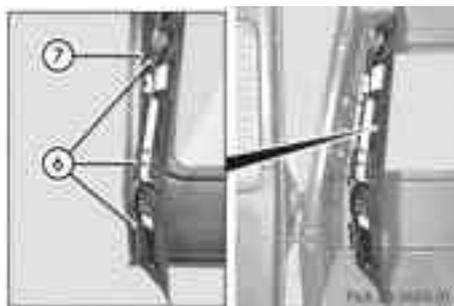
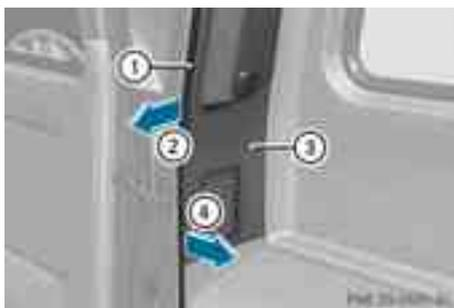

- ▶ Reconnect the electrical connections.
- ▶ Refit rear panel trim ③. When doing so, hook lugs ⑥ of rear panel trim ③ into vehicle side wall ⑦.
- ▶ Refit edge protection ①.
- ▶ Close the rear door.

### Problems with the sliding sunroof

#### **WARNING**

You could be severely or even fatally injured when closing the sliding sunroof with increased closing force or if the anti-entrapment feature is deactivated. Make sure that nobody can become trapped when closing the sliding sunroof.

- ❗ If the sliding sunroof cannot be fully opened or closed due to a malfunction, contact a qualified specialist workshop.

**Problem: the sunroof cannot be closed and you cannot see the cause.**

If the sliding sunroof is obstructed during closing and reopens again slightly:

- ▶ Immediately after the sliding sunroof blocks, pull the  switch in the overhead control panel down to the point of resistance and hold it until the sliding sunroof is closed.

If the sliding sunroof is obstructed again during closing and reopens again slightly:

- ▶ Immediately after the sliding sunroof blocks, pull the  switch in the overhead control panel down to the point of resistance and hold it until the sliding sunroof is closed.

## Soft top (G-Class Cabriolet)

### Important safety notes

#### WARNING

If the closed soft top is not locked, it can open while the vehicle is in motion. This could cause you to lose control of the vehicle. There is a risk of an accident.

Only drive with the soft top fully open or closed.

- ❗ Never sit on the soft top or store heavy objects on it. Otherwise, the soft top will be damaged.

- ❗ The soft top swings upwards when it is opened or closed. In order to avoid damaging the soft top or other parts of the vehicle when opening or closing the soft top, observe the following:

- there must be sufficient clearance above the vehicle.
- the tonneau cover must not be attached to the opened soft top.
- the luggage compartment cover must not be pushed up by the load.
- there must not be any objects on the luggage compartment cover.
- no roof rack must be fitted.

- the outside temperature must be over  $-15^{\circ}\text{C}$ .
- the fabric must not be dirty, wet or frozen.
- the vehicle must not be parked at a steep angle, e.g. off-road.
- zip fasteners and quick-release fasteners must be closed.

The soft top can only be opened and closed if the vehicle is stationary.

- i** Make sure the soft top is dry before opening it. Water could otherwise enter the vehicle interior or luggage compartment.
- i** Avoid repeatedly opening and closing the soft top. This discharges the battery.

### Operating the soft top

#### Opening

- ▶ Move the selector lever to **P**.
- ▶ Apply the parking brake.
- ▶ Turn the key to position **2** in the ignition lock.
- ▶ Fold raised sun visors onto the windscreen.

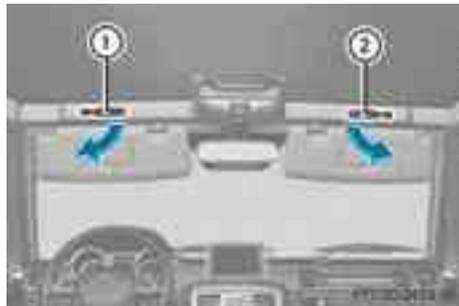

- ▶ Swing release lever ① to the left until a warning tone sounds.
- ▶ Swing release lever ② to the right, a warning tone sounds.  
The soft top is unlocked.



③ To close the soft top

④ To open the soft top

- ▶ Pull the soft-top switch in the direction of arrow ④ until the soft top is fully open and the warning tone stops.
- ▶ Swing release lever ① and ② back to their original positions. The warning tone ceases.



③ To close the soft top

④ To open the soft top

- ▶ Press the soft-top switch in the direction of arrow ③ until the soft top stops above the windscreen.

### Closing

- ▶ Move the selector lever to **P**.
- ▶ Apply the parking brake.
- ▶ Turn the key to position **2** in the ignition lock.
- ▶ Fold raised sun visors onto the windscreen.

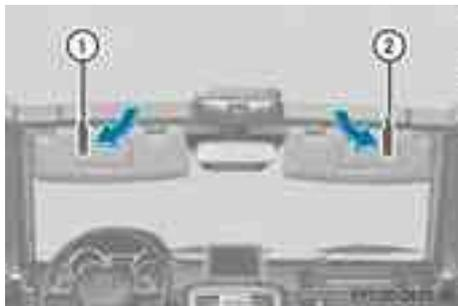

- ▶ Swing release lever ① to the left until a warning tone sounds.
- ▶ Swing release lever ② to the right until a warning tone sounds.

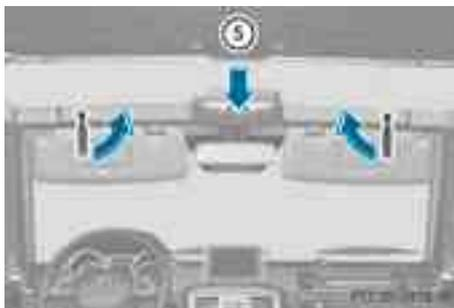

- ▶ Pull down the soft top using handle ⑤ until at least one of the release levers engages audibly.
- ▶ Swing this release lever back to its original position first.
- ▶ Swing the second release lever back to its original position. The warning tone ceases.

### Closing the soft top manually

#### WARNING

Closing the roof manually is a complicated and technically demanding procedure, which requires a lot of strength. You or others can become trapped. There is a risk of injury. If possible, have the roof closed manually at a qualified specialist workshop.

**⚠ WARNING**

If anywhere other than the indicated gripping points is gripped, you or others can become trapped or stuck. There is a risk of injury. Take off jewellery and watches. Only hold the indicated gripping points. Do not reach between the cover halves and into the hinges.

- ▶ Move the selector lever to **P**.
- ▶ Apply the parking brake.
- ▶ Remove the key from the ignition lock.
- ▶ Fold raised sun visors down.



- ▶ Swing release lever ① and ② down in the direction of the arrow.
- ▶ Open the front-passenger door.



- ▶ Pull door seal ③ off slightly.
- ▶ Remove side trim panel ④ on the right side.



- ▶ Turn hexagonal nut ⑤ anti-clockwise as far as possible.



- ▶ Press catch ⑥ on both sides of the vehicle in the direction of the arrow and, at the same time, raise the soft top.
- ▶ Fold the soft top completely to the front.

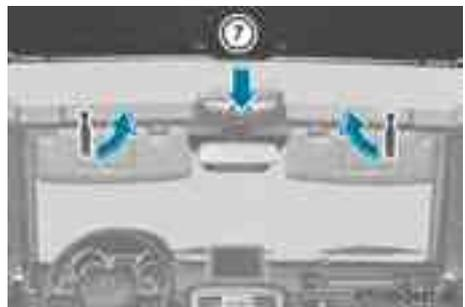

- ▶ Pull down the soft top using handle ⑦ until at least one of the release levers engages audibly.
- ▶ Swing the engaged release lever up.
- ▶ Swing the second release lever up.

**Draught stop****General notes****⚠ WARNING**

If the draught stop is incorrectly fitted, it could detach itself during a journey and endanger other road users. There is a risk of an accident and injury.

Fit the draught stop as described. Do not place any objects on top of the fitted draught stop.

The draught stop protects against wind when driving with the soft top open. It is located in a bag behind the rear bench seat.

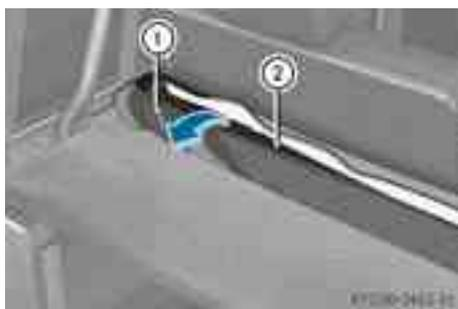
**Fitting the draught stop**

- ▶ Take draught stop (2) out of bag with zip (1).

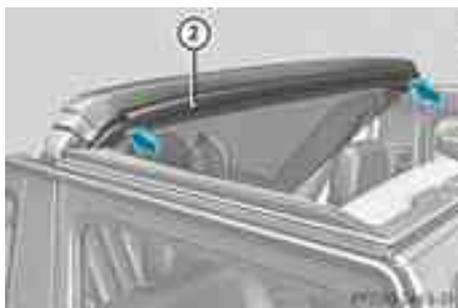

- ▶ Attach the rails of draught stop (2) to the vehicle roll bar.



- ▶ Hook securing bar (3) into brackets (4) in the side trim panels on both sides.
- ▶ Press securing bar (3) into brackets (4) until you feel it engage on both sides.

**Removing the draught stop**

- ▶ Pull securing bar (3) out of bracket (4) on both sides.



- ▶ Unhook the rails of draught stop (2) from the roll bar.

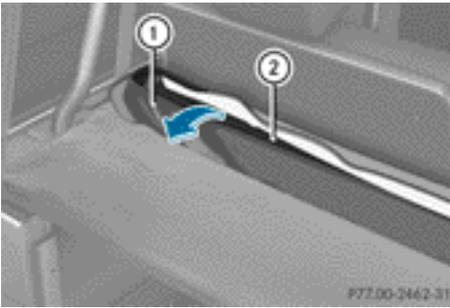

- ▶ Store draught stop ② in bag with zip ①.

### Tonneau cover

#### General notes

The tonneau cover protects the opened soft top from dirt and the effects of weather. It is located in a bag in the luggage compartment.

#### Fitting the tonneau cover

- ▶ Take the tonneau cover out of the bag in the load compartment.
- ▶ Fold out the tonneau cover and lay it over the opened soft top.

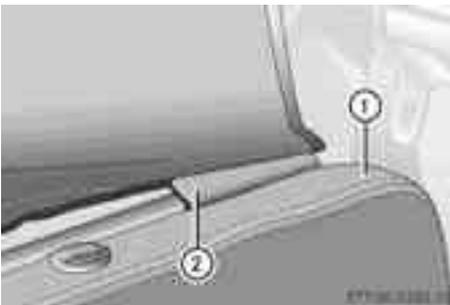

- ▶ Attach securing hooks ② to rear seat backrest ① on both sides.

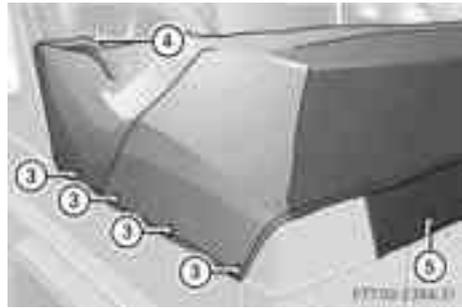

- ▶ Pull Tenax® safety catches ③ apart to release them.
- ▶ Press Tenax® safety catches ③ onto the corresponding pegs on the vehicle.
- ▶ Press safety buttons ④ onto the corresponding pegs on the vehicle.
- ▶ Push quick-release fasteners ⑤ into the corresponding holes on the tailgate until they engage.

#### Removing the tonneau cover

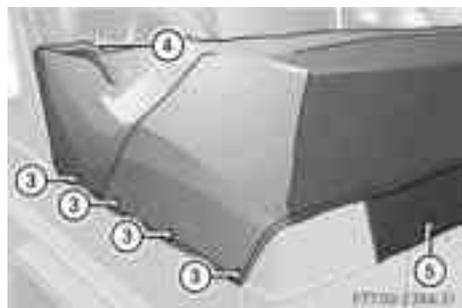

- ▶ Turn quick-release fasteners ⑤ anti-clockwise and pull out.
- ▶ Detach safety buttons ④.
- ▶ Release Tenax® safety catches ③ by pulling.

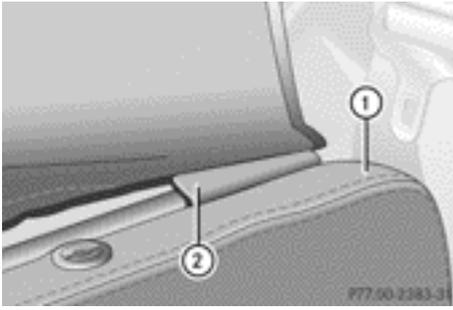

- ▶ Detach securing hooks ②.
- ▶ Fold up the tonneau cover and stow it in the bag in the luggage compartment.

Problems with the soft top	
Problem	Possible causes/consequences and ► Solutions
The soft top cannot be opened or closed.	The soft top closing procedure has been interrupted. ► Wait approximately five seconds, then repeat the procedure.
	The fuse is faulty. ► Check the fuse and replace it if necessary (▷ page 314).
	The hydraulic pump is overheated. ► Wait several minutes, then repeat the procedure.
	The control unit is malfunctioning because the closing procedure was interrupted. ► Turn the key to position <b>0</b> and then back to <b>2</b> (▷ page 143) in the ignition lock. ► Close the soft top again.
	If it still cannot be closed electrically: ► Close the soft top manually (▷ page 82). ► Have the system checked at a qualified specialist workshop.



Useful information .....	90
Correct driver's seat position .....	90
Seats .....	91
Steering wheel .....	97
Mirrors .....	99
Memory functions .....	102

## Useful information

**i** This Owner's Manual describes all models, series and optional equipment for your vehicle that were available at the time of going to press. Country-specific differences are possible. Note that your vehicle may not be fitted with all features described. This is also the case for systems and functions relevant to safety.

**i** Read the information on qualified specialist workshops: (▷ page 22).

## Correct driver's seat position



① Steering wheel

② Seat belts

③ Backrest

- ▶ Observe the safety guidelines on seat adjustment (▷ page 91).
- ▶ Make sure that seat ③ is adjusted properly.

Electrical seat adjustment (▷ page 92)

When adjusting the seat, make sure that:

- you are as far away from the driver's airbag as possible.
- you are sitting in a normal upright position.
- you can fasten the seat belt properly.

- you have moved the backrest to an almost vertical position.
- you have set the seat angle so that your thighs are gently supported.
- you can depress the pedals properly.

- ▶ Check whether the head restraint is adjusted properly (▷ page 92).

When doing so, make sure that you have adjusted the head restraint so that the back of your head is supported at eye level by the centre of the head restraint.

- ▶ Observe the safety guidelines on steering wheel adjustment (▷ page 91).
- ▶ Make sure that steering wheel ① is adjusted properly.

Adjusting the steering wheel electrically (▷ page 97)

When adjusting the steering wheel, make sure that:

- you can hold the steering wheel with your arms slightly bent.
- you can move your legs freely.
- you can see all the displays in the instrument cluster clearly.
- ▶ Observe the safety guidelines for seat belts (▷ page 43).
- ▶ Check whether you have fastened seat belt ② properly (▷ page 44).

The seat belt should:

- fit snugly across your body
- be routed across the middle of your shoulder
- be routed in your pelvic area across the hip joints
- ▶ Before starting off, adjust the rear-view mirror and the exterior mirrors in such a way that you have a good view of road and traffic conditions (▷ page 99).
- ▶ **Vehicles with a memory function:** save the seat, steering wheel and exterior mirror settings with the memory function (▷ page 102).

## Seats

### Important safety notes

#### WARNING

The seats can still be adjusted when there is no key in the ignition lock. For this reason, children should never be left unsupervised in the vehicle. They could adjust the seats and become trapped.

#### WARNING

Only adjust the driver's seat when the vehicle is stationary. You will otherwise be distracted from the road and traffic conditions and you could lose control of the vehicle as a result of the seat moving. This could cause an accident.

#### WARNING

If you adjust the seat height carelessly, you or others could be trapped and thereby injured. Children in particular could unintentionally press the buttons to electrically adjust the seats and become trapped.

Take care that:

- while moving the seats, your hands do not get under the lever assembly of the seat adjustment system.
- children in the vehicle do not slide their hands under the levers.

#### WARNING

Make sure that nobody can become trapped when adjusting the seats.

Observe the notes on airbags.

Secure children as recommended; see the "Children in the vehicle" section.

#### WARNING

Make sure that the back of your head is supported at eye level by the central area of the head restraint. If your head is not supported correctly by the head restraint, you could suffer a severe neck injury in the event of an

accident. Never drive if the head restraints are not engaged and set correctly.

#### WARNING

Occupants should only travel sitting on seats which have the head restraints fitted. On a seat which is occupied, move the head restraint into the upright position. This reduces the risk of injury to the passenger in the event of an accident.

#### WARNING

A seat belt can only offer its intended degree of protection when the backrest is almost vertical and the occupant is sitting upright. Avoid seat positions that do not allow the seat belt to be routed correctly. Adjust the backrest so that it is as upright as possible. Never travel with the backrest reclined too far backwards. You could otherwise be seriously or even fatally injured in the event of an accident or sudden braking.

 To avoid damage to the seats and the seat heating, observe the following information:

- do not spill any liquids on the seats. If liquid is spilled on the seats, dry them as soon as possible.
- if the seat covers are damp or wet, do not switch on the seat heating. The seat heating should also not be used to dry the seats.
- clean the seat covers as recommended; see the "Interior care" section.
- do not transport heavy loads on the seats. Do not place sharp objects on the seat cushions, e.g. knives, nails or tools. The seats should only be occupied by passengers, if possible.
- when the seat heating is in operation, do not cover the seats with insulating materials, e.g. blankets, coats, bags, seat covers, child seats or booster seats.

 Make sure that there are no objects in the footwell or behind the seats when moving

the seat back. There is a risk that the seats and/or the objects could be damaged.

**!** When the rear bench seat is folded forwards, the front seats cannot be moved to their rearmost position. You could otherwise damage the seats and the rear bench seat.

**!** Make sure that the sun visor is folded up before adjusting the backrest and head restraint height. The head restraint and sun visor could otherwise collide when the head restraint is fully extended.

**i** If the front door is open, the seats can be adjusted for up to 30 minutes after the ignition has been switched off.

**i** The rear-compartment head restraints can be removed (> page 93). For more information, contact a qualified specialist workshop.

**i** You can find further information about enlarging the luggage compartment (folding the rear bench seat forwards) on (> page 270).

### Adjusting the seats electrically

**!** Make sure that the cupholder on the centre console is folded down before you move the front-passenger seat forwards.

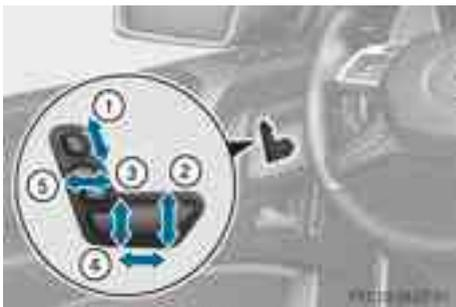

- ① Head restraint height
- ② Seat cushion angle
- ③ Seat height

- ④ Seat fore-and-aft adjustment
- ⑤ Backrest angle

**i** You can store the seat settings using the memory function (> page 102).

### Adjusting the head restraints

#### Important safety notes

#### **!** WARNING

Occupants should only travel sitting on seats that have the head restraints fitted. This reduces the risk of injury to the occupant in the event of an accident.

#### Adjusting the front seat head restraint height



- ① Head restraint height
- ② Seat cushion angle
- ③ Seat height
- ④ Seat fore-and-aft adjustment
- ⑤ Backrest angle

► Slide head restraint adjustment button ① up or down in the direction of the arrow.

#### Adjusting the luxury head restraints

#### **!** WARNING

When folding back the head restraint side bolsters, do not put your hands between the side bolster and the cushion holder. There is a danger of becoming trapped.



- ▶ **To adjust the side bolsters of the head restraint:** push or pull right and/or left-hand side bolster ① into the desired position.
- ▶ **To adjust the angle of the head restraint:** push or pull the head restraint in the direction of arrow ②.

### Resetting the front seat head restraints

It is necessary to reset the front seat head restraints after the voltage supply has been interrupted, e.g. if the battery has been completely discharged or disconnected.

- ▶ Make sure that the cup holder on the centre console is folded down (▶ page 275).
- ▶ Move the seat as far forward as possible and the head restraint in as far as possible.

### Rear seat head restraints

#### Important safety notes

**⚠ WARNING**

Drive only with the head restraints fitted. This reduces the risk of injury in the event of an accident.

Occupants must only travel on seats with head restraints fitted. Pull the head restraints up into the upright position. This reduces the risk of injury to occupants in the event of an accident.

Ensure that the back of your head is supported at eye level by the centre of the head restraint. This reduces the risk of injury to

your head or neck in the event of an accident or a similar situation.

### Adjusting the rear seat head restraint height



- ▶ Once the head restraint is fully lowered, press release catch ①.
- ▶ **To raise:** pull the head restraint up to the desired position.
- ▶ **To lower:** press release catch ① and push the head restraint down until it is in the desired position.

### Fitting/removing the rear seat head restraints

**⚠ WARNING**

Occupants should only travel sitting on seats that have the head restraints fitted. This reduces the risk of injury to the occupant in the event of an accident.

- ▶ **To remove:** pull the head restraint up to the stop.
- ▶ Press release catch ① and pull the head restraint out of the guides.
- ▶ **To refit:** place the head restraint in the guides of the backrest.
- ▶ **i** The notches on the guide rod must be on the left-hand side when viewed in the direction of travel.
- ▶ Push the head restraint down until you hear it engage in position.

### Adjusting the multicontour seat

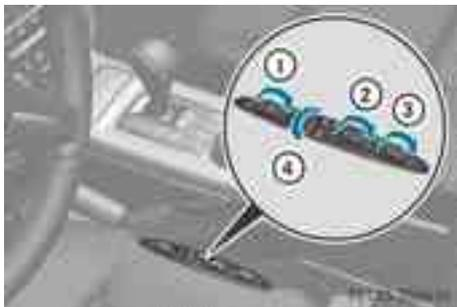

- ① To adjust the thigh cushion
- ② To adjust the backrest contour in the lumbar region
- ③ To adjust the backrest contour in the upper back region
- ④ To adjust the side bolsters of the seat backrest

You can adjust the contour of the front seats individually so as to provide optimum support for your back and sides.

- Make sure that the key is in position 1 or 2 (► page 143) in the ignition lock.

### Adjusting the 4-way lumbar support

You can adjust the contour of the front seat backrests individually to provide optimum support for your back.

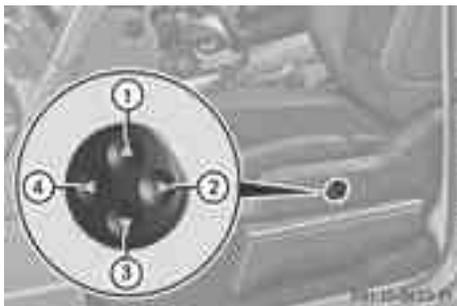

- ① To raise the backrest contour
- ② To soften the backrest contour
- ③ To lower the backrest contour
- ④ To harden the backrest contour

### Folding the front seats forward (EASY-ENTRY, G-Class Cabriolet)

#### General notes

#### WARNING

Make sure that nobody can become trapped when moving the seat. If there is a risk of someone becoming trapped, press the seat adjustment switch on the door.

- ❗ Make sure that there are no objects in the footwell or behind the seats when moving the seat back. There is a risk that the seats and/or the objects could be damaged.



- ① Backrest
- ② Seat release lever

The EASY-ENTRY feature makes it easier for passengers to get in and out of the rear compartment.

#### Folding the seat forward

- ❗ Make sure that you only fold backrest ① forwards when the EASY-ENTRY procedure is complete. Otherwise, you may damage the multicontour seat switch and the centre console.
- Pull seat release lever ② upwards in the direction of the arrow. The EASY-ENTRY feature is activated.

The following adjustments are made:

- the seat cushion and head restraint move down.
  - the seat moves forwards or backwards, depending on the starting position.
  - backrest ① tilts forwards.
  - on the driver's side, the steering wheel moves upwards and towards the dashboard.
- ▶ Fold backrest ① forwards in the direction of the arrow.

### Folding the seat back

- ▶ Push backrest ① back until the seat engages.  
The seat cushion, head restraint, backrest and steering wheel (driver's side) move back to their original positions.

For safety reasons, the seat only moves to its original position if this is in front of the EASY-ENTRY position.

- ❗ Store the seat position using the memory function (▶ page 102).
- ❗ If your seat position is behind the EASY-ENTRY position, you can return to this position by pressing one of the memory buttons.



Foot anti-entrapment feature

### Interrupting the EASY-ENTRY feature

To interrupt the EASY-ENTRY feature you can do the following:

- ▶ Press one of the seat adjustment buttons (▶ page 92).
- ▶ Press the memory function adjustment button (▶ page 102).
- ▶ Move the steering wheel adjustment lever (▶ page 97).

### Switching the seat heating on/off

#### General notes

#### ⚠ WARNING

Repeatedly setting the seat heating to level **3** may result in excessive seat temperatures. The health of passengers that have limited temperature sensitivity or a limited ability to react to excessively high temperatures may be affected or they may even suffer burn-like injuries. Therefore, do not use seat heating level **3** repeatedly.

The red indicator lamps in the button indicate the heating level you have selected.

- ▶ Make sure that the key is in position **1** or **2** in the ignition lock.

- ❗ If the battery voltage is too low, the seat heating may switch off.

### Switching the front-seat heating on/off



► **To switch on:** press button ① repeatedly until the desired heating level is set.

► **To switch off:** press button ① repeatedly until all the indicator lamps go out.

**i** The system automatically switches down from level **3** to level **2** after approximately 8 minutes.

The system automatically switches down from level **2** to level **1** after approximately 10 minutes.

The system automatically switches off approximately 35 minutes after it is set to level **1**.

### Switching the rear-seat heating on/off



► **To switch on:** press button ① repeatedly until the desired heating level is set.

► **To switch off:** press button ① repeatedly until all the indicator lamps go out.

**i** The system automatically switches down from level **3** to level **2** after approximately 8 minutes.

The system automatically switches down from level **2** to level **1** after approximately 10 minutes.

The system automatically switches off approximately 35 minutes after it is set to level **1**.

### Problems with the seat heating

If the on-board voltage is too low, the seat heating is switched off automatically.

► Switch off electrical consumers which you do not need, such as the rear window heating or interior lighting.

If the on-board voltage is only interrupted briefly, the seat heating will switch back on automatically. If the seat heating is not switched on automatically:

► switch the seat heating on manually (▷ page 95)

### Switching the seat ventilation on/off

#### Switching on/off



Seat ventilation is only available for the front seats.

The three blue indicator lamps in the buttons indicate the ventilation level you have selected.

► Make sure that the key is in position **1** or **2** (▷ page 143) in the ignition lock.

► **To switch on:** press button ① repeatedly until the desired ventilation level is set.

**i** If you open the side windows and the sliding sunroof using the key (▷ page 78), the driver's seat ventilation automatically switches to the highest level.

► **To switch off:** press button ① repeatedly until all the indicator lamps go out.

- i** If the battery voltage is too low, the seat ventilation may switch off.

### Problems with the seat ventilation

If one or all of the indicator lamps in the seat ventilation button are flashing, the seat ventilation has switched off automatically. The vehicle's electrical system voltage is too low because too many electrical consumers are switched on.

- Switch off electrical consumers that you do not need, such as the rear window heating or interior lighting.  
Once the battery is sufficiently charged, the seat ventilation will switch back on automatically.

## Steering wheel

### Important safety notes

#### **⚠ WARNING**

Do not adjust the steering wheel while driving. Adjusting the steering wheel while driving could cause the driver to lose control of the vehicle.

The electrical steering wheel adjustment can be operated at any time. Therefore, do not leave children unattended in the vehicle or with access to an unlocked vehicle. Children having unsupervised access to a vehicle could result in an accident and/or serious personal injury.

### Adjusting the steering wheel

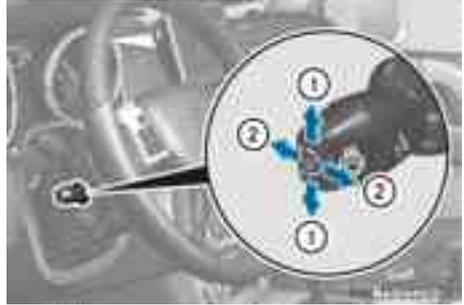

- ① To adjust the steering wheel height
  - ② To adjust the steering wheel position (fore-and-aft adjustment)
- i** If the driver's door is open, the steering wheel can be adjusted for up to 30 minutes after the ignition has been switched off.
- i** Further related subjects:
- EASY-ENTRY/EXIT feature (> page 98)
  - Storing settings (> page 102)

### Steering wheel heating

#### Switching on/off

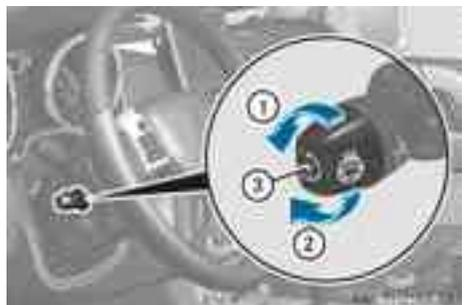

- ① To switch on the steering-wheel heating
- ② To switch off the steering-wheel heating
- ③ Indicator lamp

The steering-wheel heating heats the leather areas of the steering wheel.

- ▶ **To activate:** make sure that the key is in position **1** or **2** in the ignition lock.
  - ▶ Turn the catch in the direction of arrow ①.  
Indicator lamp ③ lights up.
  - ▶ **To deactivate:** make sure that the key is in position **1** or **2** in the ignition lock.
  - ▶ Turn the catch in the direction of arrow ②.  
Indicator lamp ③ goes out.
- i** The steering wheel heating does not switch off automatically.

### Problems with the steering wheel heating

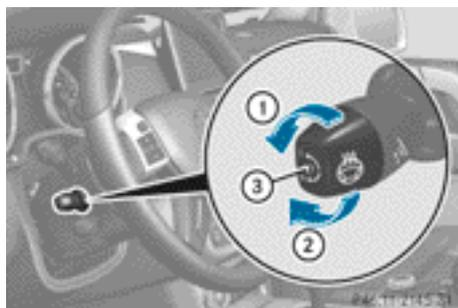

- ① To switch on the steering-wheel heating
- ② To switch off the steering-wheel heating
- ③ Indicator lamp

If steering wheel heating indicator lamp ③ is flashing, the steering wheel heating has switched off automatically. The vehicle's electrical system voltage is too low because too many electrical consumers are switched on.

- ▶ Switch off electrical consumers that you do not need, such as the rear window heating or interior lighting.  
Once the battery is sufficiently charged, the steering wheel heating will switch back on automatically.

### Steering wheel EASY-ENTRY/EXIT feature

#### Important safety notes

##### WARNING

Make sure that nobody can become trapped when you activate the EASY-ENTRY/EXIT feature.

If there is a risk of someone becoming trapped, stop the adjustment procedure. To halt the procedure:

- press the steering column adjustment button.
- briefly press one of the memory function position buttons.

The steering column stops moving immediately.

Do not keep the memory function position button pressed down, otherwise the memory function will start and the steering wheel and seat will begin to move.

Never leave children unsupervised in the vehicle. They could open the driver's door and thereby unintentionally activate the EASY-ENTRY feature and become trapped.

- !** Do not activate the EASY-ENTRY/EXIT feature, if the seat backrest is reclined too far backwards. This can damage the front or rear seats. You must first move the backrest to a vertical position.

The EASY-ENTRY/EXIT feature makes getting in and out of your vehicle easier.

You can activate and deactivate the EASY-ENTRY/EXIT feature in the on-board computer (▶ page 224).

### Position of the steering wheel when the EASY-ENTRY/EXIT feature is active

The steering wheel moves upwards and towards the dashboard if:

- you remove the key from the ignition lock or
- you open the driver's door with the key in position **0** or **1** in the ignition lock.

**i** The steering wheel only moves upwards and towards the dashboard if it has not already reached the upper end stop.

### Position of the steering wheel for driving

The steering wheel is moved to the previously set position if:

- the driver's door is closed and
- you insert the key into the ignition lock

The last position of the steering wheel is stored when you switch off the ignition or when you store the setting with the memory function (▷ page 102).

## Mirrors

### Rear-view mirror

- ▶ Adjust the rear-view mirror by hand so you have a good overview of the traffic conditions behind you.

### Exterior mirrors

#### Adjusting the exterior mirrors

#### **⚠ WARNING**

The exterior mirrors reduce the size of the image. Objects are actually closer than they appear. You could misjudge the distance from vehicles driving behind and cause an accident, e.g. when changing lane. For this reason, make sure of the actual distance from the vehicle driving behind by glancing over your shoulder.

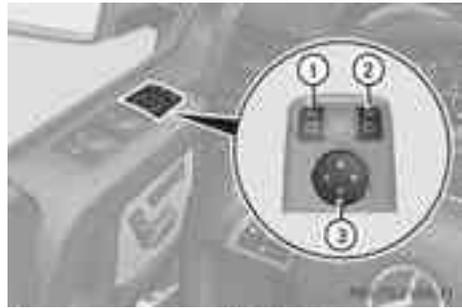

- ▶ Make sure that the key is in position **1** or **2** (▷ page 143) in the ignition lock.
  - ▶ Press button **①** to select the left-hand exterior mirror
- or
- ▶ Press button **②** to select the right-hand exterior mirror.
  - ▶ Press button **③** up, down, or to the left or right until you have adjusted the exterior mirror to the correct position. You should have a good overview of traffic conditions.

**i** The convex exterior mirrors provide a larger field of vision.

**i** The exterior mirrors are automatically heated if the rear window heating is switched on and the outside temperature is low.

#### Folding the exterior mirrors in/out electrically



- ▶ Make sure that the key is in position **1** or **2** (▷ page 143) in the ignition lock.
- ▶ Briefly press button **①**.  
Both exterior mirrors fold in or out.
- i** Make sure that the exterior mirrors are always folded out fully while driving. They could otherwise vibrate.

### Setting the exterior mirrors



If the battery has been disconnected or completely discharged, the exterior mirrors must be reset. The exterior mirrors will otherwise not fold in when you select the "Fold in mirrors when locking" function in the on-board computer (▷ page 225).

- ▶ Make sure that the key is in position **1** (▷ page 143) in the ignition lock.
- ▶ Briefly press button **①**.

### Folding the exterior mirrors in/out automatically

If the "Fold in mirrors when locking" function is activated in the on-board computer (▷ page 225):

- the exterior mirrors fold in automatically as soon as you lock the vehicle from the outside.
- the exterior mirrors fold out again automatically as soon as you unlock the vehicle and then open the driver's or front-passenger door.

### Exterior mirror pushed out of position

- ▶ Press button **①** repeatedly until you hear the mirror engage in position.  
The mirror housing is engaged again and you can adjust the exterior mirrors as usual (▷ page 99).

### Automatic anti-dazzle mirrors

#### **⚠ WARNING**

If incident light from headlamps is prevented from striking the sensor in the rear-view mirror, for instance, by luggage piled too high in the vehicle, the mirror's automatic anti-dazzle function will not operate.

Incident light could then blind you. This may distract you from the traffic conditions and, as a result, you may cause an accident.

The rear-view mirror and the exterior mirror on the driver's side automatically go into anti-dazzle mode if:

- the ignition is switched on and
  - incident light from headlamps strikes the sensor in the rear-view mirror.
- i** The mirrors do not go into anti-dazzle mode if reverse gear is engaged or if the interior lighting is switched on.

## Parking position for the exterior mirror on the front-passenger side

### Setting/storing the parking position

#### Using reverse gear

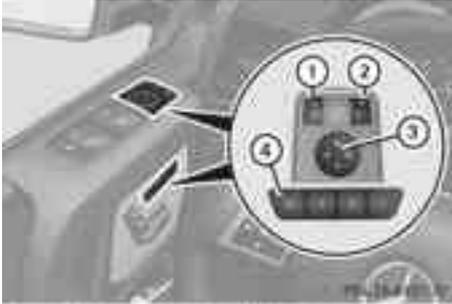

- ① Left-hand exterior mirror
- ② Right-hand exterior mirror
- ③ Adjustment button
- ④ Memory button

You can set the front-passenger side exterior mirror so that you can see the rear wheel on that side as soon as you engage reverse gear. You can store this position.

- ▶ Make sure that the vehicle is stationary and that the key is in position **2** (> page 143) in the ignition lock.
- ▶ Press button **②** for the exterior mirror on the front-passenger side.
- ▶ Engage reverse gear.  
The exterior mirror on the front-passenger side moves to the preset parking position.
- ▶ Use adjustment button **③** to adjust the exterior mirror to a position that allows you to see the rear wheel and the kerb.  
The parking position is stored.
- i** If you shift the transmission to another position, the exterior mirror on the front-passenger side returns to the driving position.

#### Using the memory button

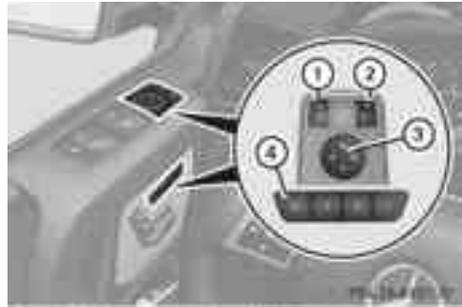

- ① Left-hand exterior mirror
- ② Right-hand exterior mirror
- ③ Adjustment button
- ④ Memory button

You can set the front-passenger side exterior mirror so that you can see the rear wheel on that side as soon as you engage reverse gear. This setting can be stored using memory button **M ④**.

- ▶ Make sure that the key is in position **2** (> page 143) in the ignition lock.
- ▶ With the exterior mirror on the front-passenger side activated, use adjustment button **③** to adjust the exterior mirror. In the exterior mirror, the rear wheel and the kerb should be visible.
- ▶ Press memory button **M ④** and one of the arrows on adjustment button **③** within three seconds.  
The parking position is stored if the exterior mirror does not move.
- ▶ If the mirror moves out of position, repeat the steps.

## Calling up a stored parking position setting

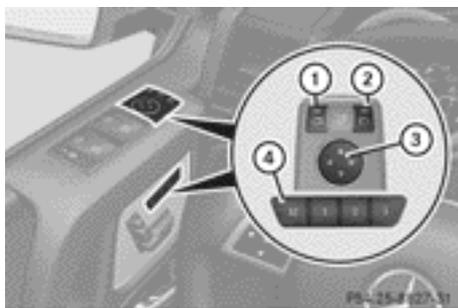

- ① Left-hand exterior mirror
- ② Right-hand exterior mirror
- ③ Adjustment button
- ④ Memory button

- ▶ Turn the key to position **2** (▷ page 143) in the ignition lock.
- ▶ Adjust the exterior mirror on the front-passenger side using button ②.
- ▶ Engage reverse gear.  
The exterior mirror on the front-passenger side moves to the stored parking position.

The exterior mirror on the front-passenger side moves back to its original position:

- as soon as you exceed a speed of 15 km/h
- if you press button ① for the exterior mirror on the driver's side

## Memory functions

### Storing settings

#### ⚠ WARNING

Only use the memory function on the driver's side when the vehicle is stationary. You could otherwise be distracted from the traffic conditions by the steering wheel and seat moving of their own accord, and as a result, cause an accident.

#### ⚠ WARNING

The memory function can still be used when the key has been removed. For this reason, children should never be left unsupervised in the vehicle. They could otherwise become trapped when adjusting the seat or the steering wheel.



- ▶ Make sure that the key is in position **2** (▷ page 143) or that the respective door is open.
- ▶ Adjust the seat (▷ page 92) and head restraint (▷ page 92).
- ▶ On the driver's side, adjust the steering wheel (▷ page 97) and the exterior mirrors (▷ page 99).
- ▶ Press the **M** memory button.
- ▶ Press one of memory buttons **1, 2 or 3** within three seconds.  
The settings are stored in the selected storage position.

## Calling up a stored setting

- ⚠ If you want to move the seat from the fully reclined position to a stored seat position, first raise the backrest using the seat switch. The seat could otherwise be damaged.
- ▶ Press and hold the relevant memory button **1, 2 or 3**, until the seat, head restraints, steering wheel and mirrors are in the stored position.
- ⓘ The setting procedure is interrupted as soon as you release the memory button.

Useful information .....	104
Exterior lighting .....	104
Interior lighting .....	110
Replacing bulbs .....	114
Windscreen wipers .....	119

### Useful information

- i** This Owner's Manual describes all models, series and optional equipment for your vehicle that were available at the time of going to press. Country-specific differences are possible. Note that your vehicle may not be fitted with all features described. This is also the case for systems and functions relevant to safety.
- i** Read the information on qualified specialist workshops: (▷ page 22).

### Exterior lighting

#### Important safety notes

For reasons of safety, Mercedes-Benz recommends that you drive with the lights switched on even during the daytime. In some countries, operation of the headlamps varies due to legal requirements and self-imposed obligations.

#### Driving abroad

#### Converting to symmetrical dipped beam

If your journey takes you to countries where vehicles are driven on the opposite side of the road to the country in which the vehicle is registered, your headlamps must be switched to symmetrical dipped beam. This prevents oncoming traffic from being dazzled. Symmetrical lights do not illuminate as large an area of the edge of the carriageway.

Have the headlamps converted at a qualified specialist workshop as close to the border as possible before driving in these countries.

#### Converting to asymmetrical dipped beam after returning

Have the headlamps converted back to asymmetrical dipped-beam headlamps at a quali-

fied specialist workshop as soon as possible after crossing the border again.

### Light switch

#### Operation

- !** Switch off the side lamps and dipped-beam headlamps when you leave the vehicle. This prevents the battery from discharging.
- !** If the battery has been excessively discharged, the side lamps or parking lamps are automatically switched off to enable the next engine start. Always park your vehicle safely and sufficiently lit according to legal standards. Avoid the continuous use of the  side lamps for several hours. If possible, switch on the  right or the  left parking lamp.

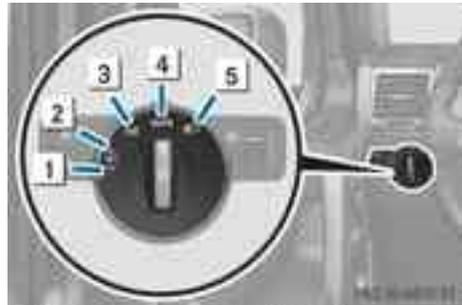

- 1**  Left-hand parking lamps
- 2**  Right-hand parking lamps
- 3**  Side lamps, licence plate and instrument cluster lighting
- 4**  Automatic headlamp mode/daytime driving lights
- 5**  Dipped-beam/main-beam headlamps

If you hear a warning tone when you leave the vehicle, the lights may still be switched on.

- Turn the light switch to .

The turn signals, main-beam headlamps and the headlamp flasher are operated using the combination switch (▷ page 108).

The exterior lighting (except the side lamps/parking lamps) switches off automatically if you:

- remove the key from the ignition lock
- open the driver's door with the key in position **0**

### Dipped-beam headlamps

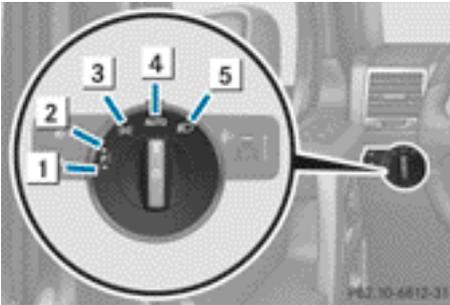

- 1** Left-hand parking lamps
- 2** Right-hand parking lamps
- 3** Side lamps, licence plate and instrument cluster lighting
- 4** **AUTO** Automatic headlamp mode/daytime driving lights
- 5** Dipped-beam/main-beam headlamps

- **To switch on the dipped-beam headlamps:** turn the key in the ignition lock to position **2** or start the engine.
- Turn the light switch to . The indicator lamp in the instrument cluster lights up.

### Daytime driving lights

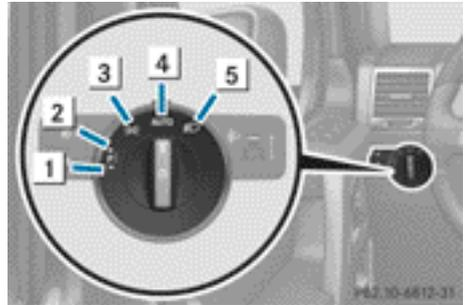

- 1** Left-hand parking lamps
- 2** Right-hand parking lamps
- 3** Side lamps, licence plate and instrument cluster lighting
- 4** **AUTO** Automatic headlamp mode/daytime driving lights
- 5** Dipped-beam/main-beam headlamps

You can set the "daytime driving lights" function via the on-board computer (> page 222).

- **Daytime driving lights:** activate the daytime driving lights function using the on-board computer.
- Turn the light switch to **AUTO**.  
When the engine is on: depending on the ambient light conditions, the daytime driving lights or the parking and dipped-beam headlamps are switched on.  
When the dipped-beam headlamps are switched on, the indicator lamp in the instrument cluster lights up.

### Automatic headlamp mode

#### **WARNING**

If the light switch is set to **AUTO** and it is foggy, snowing or there is poor visibility, the dipped-beam headlamps will not come on automatically. This could endanger you and others. In such situations turn the light switch to .

The automatic headlamp feature is only an aid. The driver is responsible for the vehicle's lighting at all times.

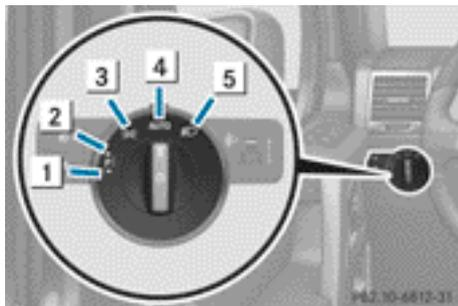

- 1 Left-hand parking lamps
- 2 Right-hand parking lamps
- 3 Side lamps, licence plate and instrument cluster lighting
- 4 Automatic headlamp mode/daytime driving lights
- 5 Dipped-beam/main-beam headlamps

► **To switch on automatic headlamp mode:** turn the light switch to **AUTO**.

Key in position **1** in the ignition lock: the side lamps are switched on or off automatically depending on the brightness of the ambient light.

With the engine running: if you have activated the daytime driving lights function in the on-board computer, the daytime driving lights or the dipped-beam headlamps are switched on or off automatically depending on the brightness of the ambient light.

When the dipped-beam headlamps are switched on, the indicator lamp in the instrument cluster lights up.

### Foglamps (except AMG vehicles)

**WARNING**

If you suspect that driving conditions will be foggy, turn the light switch to before you start your journey. Your vehicle may other-

wise not be visible and you could endanger yourself and others.

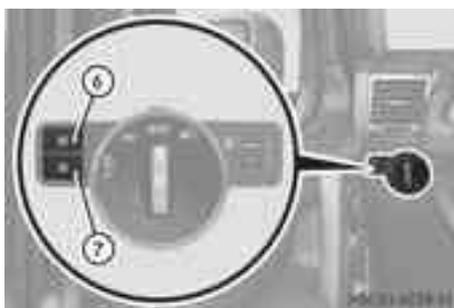
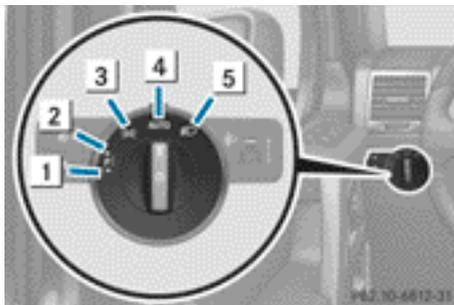

- 1 Left-hand parking lamps
- 2 Right-hand parking lamps
- 3 Side lamps, licence plate and instrument cluster lighting
- 4 Automatic headlamp mode/daytime driving lights
- 5 Dipped-beam/main-beam headlamps
- 6 Foglamps (except AMG vehicles)
- 7 Rear foglamp

► **To switch on the foglamps:** turn the key in the ignition lock to position **2** or start the engine.

► Turn the light switch to , or **AUTO**.

- ▶ Press the  button.  
The green  indicator lamp in the instrument cluster lights up.
- ▶ **To switch off the front foglamps:** press the  button.  
The green  indicator lamp in the instrument cluster goes out.

Only vehicles with front foglamps have the "Foglamps" function.

- ▶ **To switch on the rear foglamp:** turn the key in the ignition lock to position **2** or start the engine.
- ▶ Turn the light switch to  or **AUTO**.
- ▶ Press the  button.  
The yellow  indicator lamp in the instrument cluster lights up.
- ▶ **To switch off the rear foglamp:** press the  button.  
The yellow  indicator lamp in the instrument cluster goes out.

### Rear foglamp

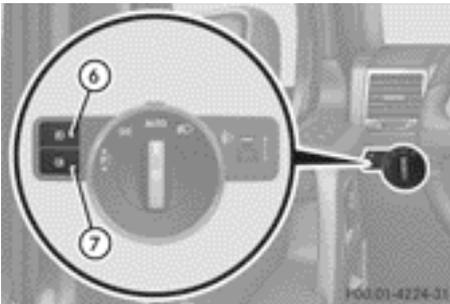
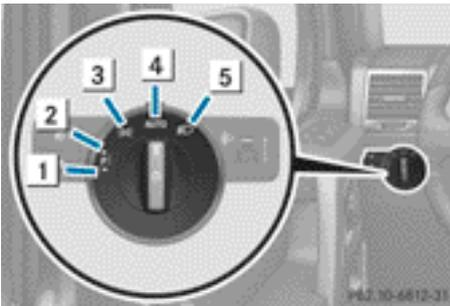

- 1  Left-hand parking lamps
- 2  Right-hand parking lamps
- 3  Side lamps, licence plate and instrument cluster lighting
- 4 **AUTO** Automatic headlamp mode/daytime driving lights
- 5  Dipped-beam/main-beam headlamps
- 6  Foglamps (except AMG vehicles)
- 7  Rear foglamp

### Side lamps

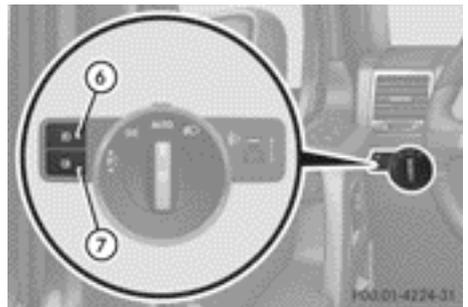
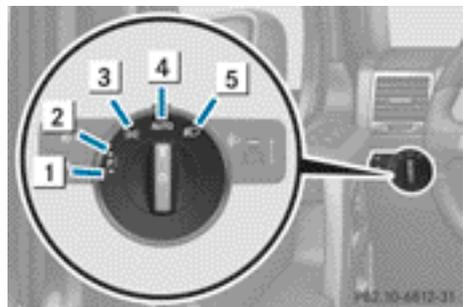

- 1  Left-hand parking lamps
- 2  Right-hand parking lamps
- 3  Side lamps, licence plate and instrument cluster lighting
- 4 **AUTO** Automatic headlamp mode/daytime driving lights
- 5  Dipped-beam/main-beam headlamps

- ⑥  Foglamps (except AMG vehicles)
- ⑦  Rear foglamp

► **To switch on:** turn the light switch to .

### Parking lamps

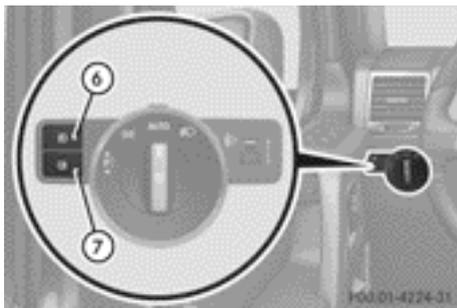
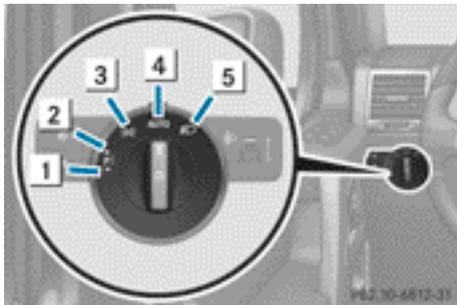

- ①  Left-hand parking lamps
- ②  Right-hand parking lamps
- ③  Side lamps, licence plate and instrument cluster lighting
- ④  Automatic headlamp mode/daytime driving lights
- ⑤  Dipped-beam/main-beam headlamps
- ⑥  Foglamps (except AMG vehicles)
- ⑦  Rear foglamp

Switching on the parking lamps ensures that the corresponding side of the vehicle is illuminated.

► **To switch on the parking lamps:** the key is not inserted in the ignition lock or it is in position 0 (▷ page 143).

► Turn the light switch to  (left-hand side of the vehicle) or  (right-hand side of the vehicle).

### Headlamp cleaning system

The headlamps are cleaned automatically if the "Wipe with washer fluid" function is operated ten times while the lights are on and the engine is running (▷ page 119). When you switch off the ignition, the automatic headlamp cleaning system is reset and counting is resumed from 0.

### Combination switch

#### Turn signals



- ① Main-beam headlamps
- ② Turn signal, right
- ③ Headlamp flasher
- ④ Turn signal, left

► **To indicate briefly:** press the combination switch briefly to the pressure point in the direction of arrow ② or ④.

The corresponding turn signal flashes three times.

► **To indicate:** press the combination switch beyond the pressure point in the direction of arrow ② or ④.

## Main-beam headlamps

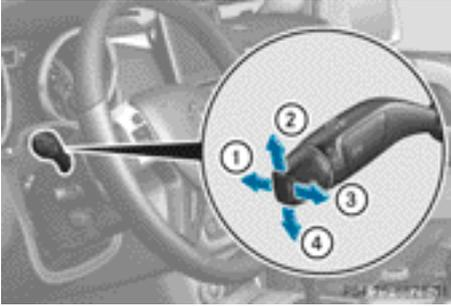

- ① Main-beam headlamps
- ② Turn signal, right
- ③ Headlamp flasher
- ④ Turn signal, left

- ▶ **To switch on the main-beam headlamps:** turn the key in the ignition lock to position **2** or start the engine.
- ▶ Turn the light switch to  or **AUTO**.
- ▶ Press the combination switch beyond the pressure point in the direction of arrow **①**.

In the **AUTO** position, the main-beam headlamps are only switched on when it is dark and the engine is running.

The blue  indicator lamp in the instrument cluster lights up when the main-beam headlamps are switched on.

- ▶ **To switch off the main-beam headlamps:** move the combination switch back to its normal position. The blue  indicator lamp in the instrument cluster goes out.

## Headlamp flasher

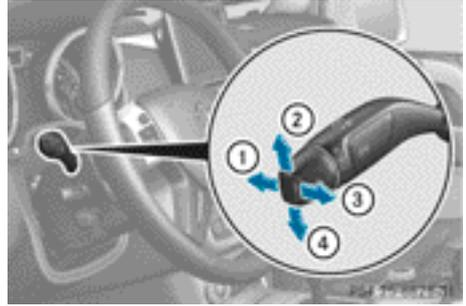

- ① Main-beam headlamps
- ② Turn signal, right
- ③ Headlamp flasher
- ④ Turn signal, left

- ▶ **To switch on:** turn the key in the ignition lock to position **1** or **2**, or start the engine.
- ▶ Pull the combination switch briefly in the direction of arrow **③**.

## Hazard warning lamps



- ▶ **To switch on the hazard warning lamps:** press button **①**. All turn signals flash. If you now switch on a turn signal using the combination switch, only the turn signal lamp on the corresponding side of the vehicle will flash.
- ▶ **To switch off the hazard warning lamps:** press button **①**.

The hazard warning lamps automatically switch on if:

- an airbag is deployed
- the seat belt tensioners are triggered, or
- the vehicle decelerates rapidly from a speed of more than 70 km/h and comes to a standstill.

The hazard warning lamp switches on automatically if an airbag or the belt tensioners are triggered and the key is in position 1 in the ignition lock.

The hazard warning lamps switch off automatically if the vehicle reaches a speed of over 10 km/h again after a full brake application.

- i** The hazard warning lamps still operate if the ignition is switched off.

### Cornering light function



The cornering light function improves the illumination of the road over a wide angle in the direction you are turning, enabling better visibility in tight bends, for example. The cornering light function can only be activated if the dipped-beam headlamps are switched on and the foglamps are switched off.

**Active:** if you are driving at speeds below 40 km/h and switch on the turn signal or turn the steering wheel

**Not active:** if you are driving at speeds above 40 km/h or switch off the turn signal or turn the steering wheel to the straight-ahead position

The cornering lamp may remain lit for a short time, but is automatically switched off after no more than three minutes.

### Headlamps and turn signals misted up on the inside

The headlamps and the indicator lamps in the exterior mirrors may mist up on the inside if there is high atmospheric humidity.

- ▶ Drive with the headlamps switched on. The level of moisture diminishes, depending on the length of the journey and the weather conditions (humidity and temperature).

If the level of moisture does not diminish:

- ▶ Have the headlamps checked at a qualified specialist workshop.

## Interior lighting

### Overview of interior lighting



Front overhead control panel

- ①  Switches the left-hand front reading lamp on/off
- ②  Switches the front interior lighting on
- ③  Switches the luggage compartment lighting/rear interior lighting on/off
- ④  Switches the front interior lighting/automatic interior lighting control off

- ⑤  Switches the right-hand reading lamp on/off
- ⑥  Switches the automatic interior lighting control on

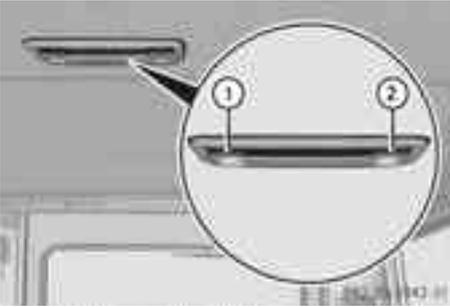

Example: rear-compartment overhead control panel, long-wheelbase G-Class

- ①  Switches the right-hand reading lamp on/off
- ②  Switches the left-hand reading lamp on/off

## Interior lighting control

### General notes

In order to prevent the vehicle's battery from discharging, the interior lighting functions are automatically deactivated after some time except for when the key is in position **2** in the ignition lock.

The brightness of the ambient lighting may be set using the control on the instrument cluster (▷ page 212).

## Automatic interior lighting control

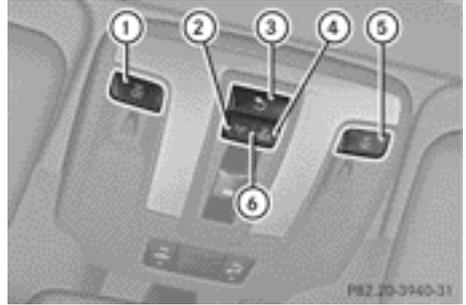

Front overhead control panel

- ①  Switches the left-hand front reading lamp on/off
- ②  Switches the front interior lighting on
- ③  Switches the luggage compartment lighting/rear interior lighting on/off
- ④  Switches the front interior lighting/automatic interior lighting control off
- ⑤  Switches the right-hand reading lamp on/off
- ⑥  Switches the automatic interior lighting control on

► **To switch on:** set rocker switch ⑥ to the centre position.

The interior lighting switches on automatically when it is dark if you:

- unlock the vehicle
- open a door
- remove the key from the ignition lock

► **To switch off:** press the  symbol on rocker switch ⑥.

The interior lighting remains switched off even when it is dark if you:

- unlock the vehicle
- open a door
- remove the key from the ignition lock

The interior lighting is activated for a short time when the key is removed from the ignition lock. You can activate this delayed switch-off using the on-board computer (▷ page 222).

When a front door is opened, the front interior lighting comes on. When a rear door is opened, the rear interior lighting comes on. In addition, the courtesy lights come on.

- i** If a door remains open and the ignition key is not in the ignition lock, the interior lighting switches off automatically after approximately 30 minutes.

## Manual interior lighting control

### Front interior lighting

- !** If the interior lighting has been switched on manually, it will not be switched off automatically.

This can cause the starter battery to discharge.

Make sure that the interior lighting does not remain switched on too long after the engine has been switched off.

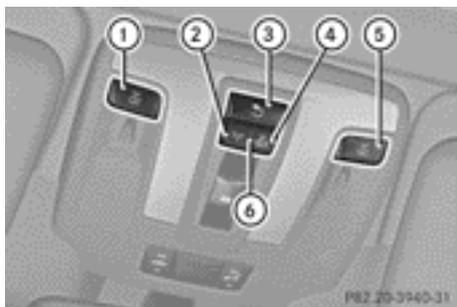

Front overhead control panel

- ① Switches the left-hand front reading lamp on/off
- ② Switches the front interior lighting on
- ③ Switches the luggage compartment lighting/rear interior lighting on/off
- ④ Switches the front interior lighting/automatic interior lighting control off
- ⑤ Switches the right-hand reading lamp on/off
- ⑥ Switches the automatic interior lighting control on

- ▶ **To switch on:** press the symbol on rocker switch ②.

- ▶ **To switch off:** set rocker switch ② to the centre position.

### Reading lamps

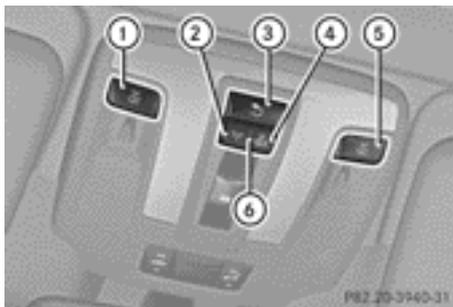

Front overhead control panel

- ① Switches the left-hand front reading lamp on/off
- ② Switches the front interior lighting on
- ③ Switches the luggage compartment lighting/rear interior lighting on/off
- ④ Switches the front interior lighting/automatic interior lighting control off
- ⑤ Switches the right-hand reading lamp on/off
- ⑥ Switches the automatic interior lighting control on

- ▶ **To activate/deactivate:** press the button.

### Luggage compartment lighting

- !** Do not close the rear door while lock ① is engaged at the bottom. Otherwise, you could damage lock ①.

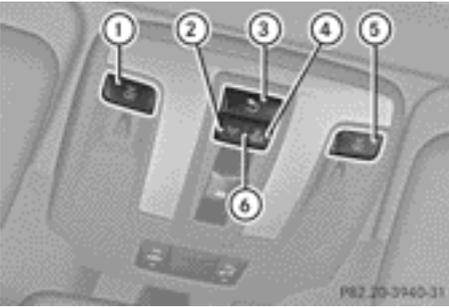

Front overhead control panel

- ① Switches the left-hand front reading lamp on/off
- ② Switches the front interior lighting on
- ③ Switches the luggage compartment lighting/rear interior lighting on/off
- ④ Switches the front interior lighting/automatic interior lighting control off
- ⑤ Switches the right-hand reading lamp on/off
- ⑥ Switches the automatic interior lighting control on

► **To switch on/off:** press the button.

**i** If you open the rear door, the luggage compartment lighting comes on. You will then be unable to switch it off using the button.

Switch off the luggage compartment lighting if you wish to leave the rear door open for a longer period. This prevents the battery from discharging.



► Open the rear door.

► **To switch off with the rear door open:** press lock ① down in the direction of the arrow until it engages.

The luggage compartment lighting is switched off.

► **To switch on with the rear door open:** press lock cylinder ② on the door handle. The luggage compartment lighting resumes its normal function.

## Rear interior lighting

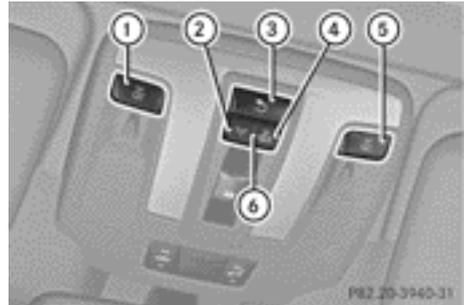

Front overhead control panel

- ① Switches the left-hand front reading lamp on/off
- ② Switches the front interior lighting on
- ③ Switches the luggage compartment lighting/rear interior lighting on/off
- ④ Switches the front interior lighting/automatic interior lighting control off
- ⑤ Switches the right-hand reading lamp on/off
- ⑥ Switches the automatic interior lighting control on

► **To switch on/off:** press the button.

**i** If you open a rear door, the rear interior lighting comes on. You will then be unable to switch it off using the button.

Switch off the rear interior lighting if you wish to leave the rear doors open for a longer period. This prevents the battery from discharging.

### Courtesy lighting in the front doors

The courtesy light is switched on to help you see better when it is dark.

- ▶ **To switch on:** activate the interior lighting automatic control.
- ▶ Open the door.
- ▶ **To switch off:** close the door.

### Replacing bulbs

#### Important safety notes

#### Xenon bulbs

##### DANGER

Xenon bulbs carry a high voltage. You could get an electric shock and be seriously or even fatally injured if you touch the electric contacts on xenon bulbs. Therefore, never remove the cover from xenon bulbs.

Do not change the xenon bulbs yourself, but have them replaced at a qualified workshop.

If your vehicle is equipped with xenon bulbs, you can recognise this by the following: the cone of light from the xenon bulbs moves from the top to the bottom and back again when you start the engine. For this to be observed, the lights must be switched on before starting the engine.

Bulbs and lamps are an important aspect of vehicle safety. You must therefore make sure that these function correctly at all times. Have the headlamp setting checked regularly.

#### LED lamps

You can neither replace xenon bulbs nor LED bulbs. Have LED bulbs changed at a qualified specialist workshop.

Bulbs and lamps are an important aspect of vehicle safety. You must therefore make sure that these function correctly at all times. Have the headlamp setting checked regularly.

### Other bulbs

##### WARNING

Bulbs and lamps can be very hot. You should therefore allow them to cool down before you change them. Otherwise, you could be burned if you touch them.

Keep bulbs out of the reach of children. Otherwise, they could damage the bulbs, for example, and injure themselves.

Never use a bulb which has been dropped. Such a bulb may break or even explode and injure you.

Halogen bulbs are pressurised and can explode when you change them, particularly if they are very hot. You should therefore wear eye protection and gloves when you are changing them.

There are bulbs other than the xenon bulbs that you cannot replace. Replace only the bulbs listed (▷ page 115). Have the bulbs that you cannot replace yourself changed at a qualified specialist workshop.

If you require assistance replacing bulbs, consult a qualified specialist workshop.

Do not touch the glass tube of new bulbs with your bare hands. Even minor contamination can burn into the glass surface and reduce the service life of the bulbs. Always use a lint-free cloth or only touch the base of the bulb when fitting.

Only use bulbs of the correct type.

If the new bulb still does not light up, consult a qualified specialist workshop.

Bulbs and lamps are an important aspect of vehicle safety. You must therefore make sure that these function correctly at all times.

Have the headlamp setting checked regularly.

## Before changing bulbs

Have the following bulbs changed at a qualified specialist workshop:

- additional turn signals in the exterior mirrors
- third brake lamp
- main-beam/dipped-beam headlamps (xenon bulbs)
- daytime driving lights
- licence plate lamp

**i** Individual segments of the licence plate lamp LEDs may fail without a display message appearing in the multifunction display. Regularly check the licence plate lighting. If necessary, visit a qualified specialist workshop.

You can replace the following bulbs:

- side lamps/parking lamps
- foglamp/cornering lamp with foglamp function
- turn signal lamp (front)
- brake/tail lamp
- turn signal lamp (rear)
- tail lamp/parking lamp
- reversing lamp
- rear foglamp

## Overview of bulb replacement – bulbs

### Front lamps

You can replace the following bulbs. The details for the bulb type can be found in the legend.



- ① Turn signal lamp: P 21 W (vehicles with white lenses: PY 21 W (yellow))
- ② Parking/side lamp: W 5 W blue
- ③ Cornering light function with foglamp function: H 11 55 W (except AMG vehicles)

### Rear lamps

You can replace the following bulbs. The details for the bulb type can be found in the legend.

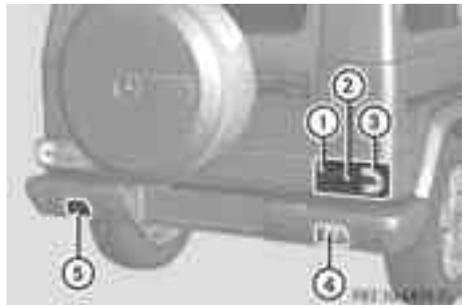

Example: G-Class, long-wheelbase version

- ① Tail lamp/parking lamp: R 5 W
- ② Brake lamp/tail lamp: P 21/5 W
- ③ Turn signal lamp: PY 21 W (yellow)
- ④ Reversing lamp: P 21 W
- ⑤ Rear foglamp: P 21 W

## Replacing the front bulbs

## Side lamps/parking lamps



- ▶ Switch off the lights.
- ▶ Loosen screws ① but do not remove.
- ▶ Remove panel ② upwards in the direction of the arrow.



- ▶ Unscrew screws ③.
- i** Only remove screws ③. Do not turn adjustment screws ④. If an adjustment screw ④ has been turned, the headlamp adjustment must be checked at a qualified workshop.



- ▶ Remove headlamp ⑤.
- ▶ Lightly press bulb holder ⑥; at the same time, turn it anti-clockwise and pull it out.



- ▶ Take bulb ⑦ out of bulb holder ⑥.
- ▶ Insert the new bulb into bulb holder ⑥.
- ▶ Insert bulb holder ⑥ into the lamp and turn it clockwise.
- ▶ Insert headlamp ⑤.
- ▶ Replace and tighten screws ③.
- ▶ Position cover ②.
- ▶ Replace and tighten screws ①.

## Front foglamps/cornering lamps with foglamp function



- ▶ Switch off the lights.
- ▶ Unscrew screws ①.
- ▶ Remove cover ②.

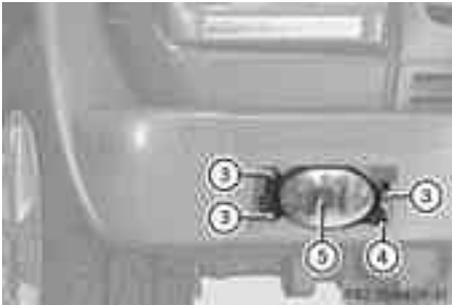

- ▶ Unscrew screws ③.
- ▶ **i** Only remove screws ③. Do not turn adjustment screw ④. If adjustment screw ④ has been turned, the front foglamp adjustment must be checked at a qualified workshop.
- ▶ Remove lamp ⑤.



- ▶ Hold lamp ⑤.
- ▶ Lightly press bulb holder ⑥, turn it anti-clockwise to the stop and pull it out.



- ▶ Take bulb ⑦ out of bulb holder ⑥.
- ▶ Insert the new bulb into bulb holder ⑥.
- ▶ Insert bulb holder ⑥ into lamp ⑤ and turn it clockwise to the stop.
- ▶ Insert lamp ⑤.
- ▶ Replace and tighten screws ③.
- ▶ Position cover ②.
- ▶ Replace and tighten screws ①.

## Turn signals

- ▶ **!** Do not fasten the screws too tightly. You could otherwise damage the lens.



- ▶ Switch off the lights.
- ▶ Unscrew screws ①.
- ▶ Remove lens ②.



- ▶ Turn bulb ③ anti-clockwise, applying slight pressure, and remove it from the bulb holder.
- ▶ Insert the new bulb into the bulb holder and turn it clockwise until it engages.
- ▶ Fit lens ②.
- ▶ Replace and tighten screws ①.

### Replacing the rear bulbs

#### Tail lamps

- ❗ When fitting the lens, make sure that the seal is positioned correctly.
- ❗ Do not fasten the screws too tightly. You could otherwise damage the lens.



- ▶ Switch off the lights.
- ▶ Unscrew screws ①.
- ▶ Remove lens ②.

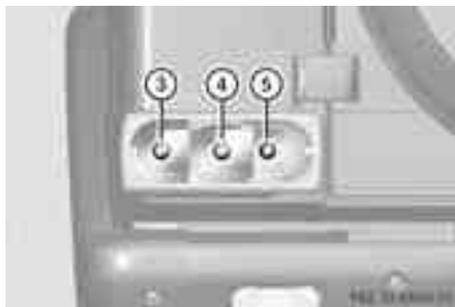

- ③ Turn signals
- ④ Brake/tail lamp
- ⑤ Tail lamp/parking lamp
- ▶ Turn the corresponding bulb anti-clockwise, applying slight pressure, and remove it from the bulb holder.
- ▶ Insert the new bulb into the bulb holder and turn it clockwise until it engages.
- ▶ Fit lens ②.
- ▶ Replace and tighten screws ①.

#### Reversing lamp/rear foglamp

- ❗ Do not fasten the screws too tightly. You could otherwise damage the lens.

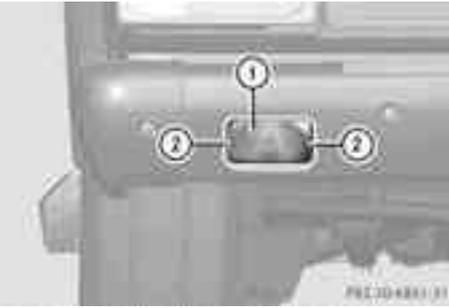

Example: rear foglamp

- ▶ Switch off the lights.
- ▶ Unscrew screws ②.
- ▶ Remove lens ①.



- ▶ Turn bulb ③ anti-clockwise, applying slight pressure, and remove it from the bulb holder.
- ▶ Insert the new bulb into the bulb holder and turn it clockwise until it engages.
- ▶ Fit lens ①.
- ▶ Replace and tighten screws ②.

## Windscreen wipers

### Switching the windscreen wipers on/off

#### **WARNING**

The windscreen will not longer be wiped properly if the wiper blades are worn. This could prevent you from observing the traffic conditions, thereby causing an accident. Replace

the wiper blades twice a year, ideally in spring and autumn.

**!** Do not operate the windscreen wipers when the windscreen/rear window is dry, as this could damage the wiper blades. Moreover, dust that has collected on the windscreen/rear window can scratch the glass if wiping takes place when the windscreen/rear window is dry.

If it is necessary to operate the windscreen wipers/rear window wiper in dry weather conditions, always use washer fluid.

**!** If the windscreen wipers leave smears on the windscreen/rear window after the vehicle has been washed in an automatic car wash, this may be due to wax or other residue. Clean the windscreen/rear window with washer fluid after an automatic car wash.

**!** Intermittent wiping with rain sensor: due to optical influences and the windscreen becoming dirty in dry weather conditions, the windscreen wipers may be activated inadvertently. This could damage the windscreen wiper blades or scratch the windscreen.

For this reason, you should always switch off the windscreen wipers in dry weather.

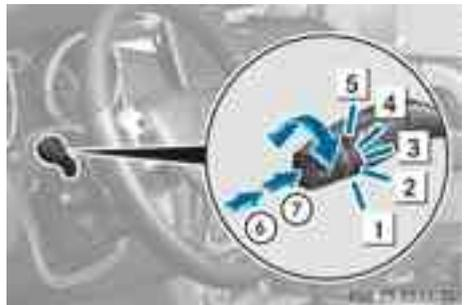

Combination switch

- ①  0 Windscreen wipers off
- ②  ... Intermittent wipe, low (rain sensor set to low sensitivity)
- ③  .... Intermittent wipe, high (rain sensor set to high sensitivity)

- 4  Continuous wipe, slow
- 5  Continuous wipe, fast
- 6  Single wipe
- 7  To wipe with washer fluid

- ▶ Turn the key to position **1** or **2** in the ignition lock.
- ▶ Turn the combination switch to the corresponding position.

Intermittent wiping is interrupted if you stop and open a front door. This protects people getting into and out of the vehicle from being sprayed with water.

In the  or  position, the appropriate wiping frequency is set automatically according to the intensity of the rain. In the  position, the rain sensor is more sensitive than in the  position, causing the windscreen wipers to wipe more frequently.

- i** When the windscreen wipers are switched on and you stop the vehicle, the windscreen wipers wipe more slowly.

### Switching the rear window wiper on/off

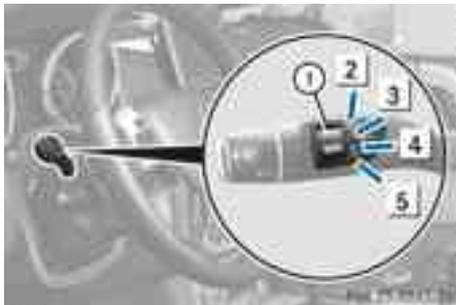

Combination switch

- ①  Switch
- 2  To wipe with washer fluid
- 3 **I** To switch on intermittent wiping
- 4 **0** To switch off intermittent wiping
- 5  To wipe with washer fluid

- ▶ Turn the key to position **1** or **2** in the ignition lock.
- ▶ Turn switch ① on the combination switch to the corresponding position. When the rear window wiper is switched on, the symbol appears in the instrument cluster.

- i** The rear window wiper comes on automatically if you shift the selector lever to **R** while the windscreen wipers are on.

### Replacing the wiper blades

#### Important safety notes

##### WARNING

The wiper arms could start moving and cause an injury if you leave the windscreen wipers switched on.

Remove the key from the ignition lock before replacing the wiper blades.

- !** To avoid damaging the windscreen wiper blades, make sure that you touch only the wiper arm of the windscreen wiper.
- !** Never open the bonnet if a windscreen wiper arm has been folded away from the windscreen.

Never fold a windscreen wiper arm without a wiper blade back onto the windscreen/rear window.

Hold the windscreen wiper arm firmly when you change the wiper blade. If you release the windscreen wiper arm without a wiper blade and it falls onto the windscreen, the windscreen may be damaged by the force of the impact.

Mercedes-Benz recommends that you have the wiper blades changed at a qualified specialist workshop.

## Removing the wiper blades

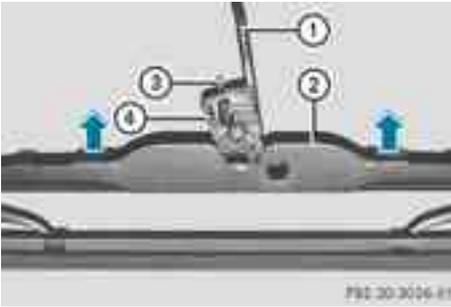

- ① Wiper arm
- ② Wiper blade
- ③ Locking spring
- ④ Hinge piece

- ▶ Remove the key from the ignition lock.
- ▶ Fold wiper arm ① away from the windscreen until it engages.
- ▶ Position wiper blade ② horizontally.
- ▶ Press locking spring ③.
- ▶ Slide wiper blade ② with hinge piece ④ from wiper arm ①.

## Fitting the wiper blade

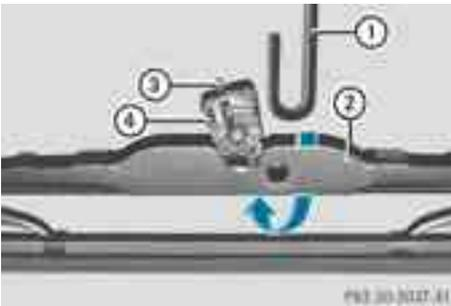

- ① Wiper arm
- ② Wiper blade
- ③ Locking spring
- ④ Hinge piece

- ▶ Slide new wiper blade ② with the recess onto wiper arm ①.
- ▶ Engage locking spring ③ into the end of the wiper arm.
- ▶ Make sure that wiper blade ② is seated correctly.
- ▶ Fold wiper arm ① back onto the windscreen.

## Problems with the windscreen wipers

### The windscreen wipers are obstructed

Leaves or snow, for example, may be obstructing the windscreen wiper movement. The wiper motor has been deactivated.

- ▶ For safety reasons, you should remove the key from the ignition lock.
- ▶ Remove the cause of the obstruction.
- ▶ Switch the windscreen wipers back on.

### The windscreen wipers are inoperative

The windscreen wiper drive is malfunctioning.

- ▶ Select another wiper speed on the combination switch.
- ▶ Have the windscreen wipers checked at a qualified specialist workshop.



Useful information .....	124
Overview of climate control systems .....	124
Operating the climate control system .....	126
Adjusting the air vents .....	139

### Useful information

- i** This Owner's Manual describes all models, series and optional equipment for your vehicle that were available at the time of going to press. Country-specific differences are possible. Note that your vehicle may not be fitted with all features described. This is also the case for systems and functions relevant to safety.
- i** Read the information on qualified specialist workshops: (▷ page 22).

### Overview of climate control systems

#### Important safety notes

#### WARNING

Observe the settings recommended on the following pages. The windows could otherwise mist up. This may prevent you from observing the traffic conditions, thereby causing an accident.

THERMATIC automatic climate control regulates the temperature and the humidity in the vehicle interior and filters undesirable substances from the air.

THERMATIC automatic climate control is only operational when the engine is running. Optimum operation is only achieved if you drive with the side windows and sliding sunroof closed.

The climatic comfort deteriorates whilst the sliding sunroof is open. The automatic climate control cannot maintain the set temperature with the sliding sunroof open. You have to adjust the climate control manually.

- i** The residual heat function can only be activated or deactivated with the ignition switched off.
- i** The residual heat function can only be activated or deactivated with the ignition switched off (▷ page 133).

- i** Ventilate the vehicle for a brief period during warm weather, e.g. using the convenience opening feature (▷ page 78). This will speed up the cooling process and the desired vehicle interior temperature will be reached more quickly.
- i** The integrated filter can filter out most particles of dust and completely filters out pollen. A clogged filter reduces the amount of air supplied to the vehicle interior. For this reason, you should always observe the interval for replacing the filter, which is specified in the Service Booklet. As it depends on environmental conditions, e.g. heavy air pollution, the interval may be shorter than stated in the Service Booklet.

## Control panel for THERMATIC automatic climate control (2-zone)

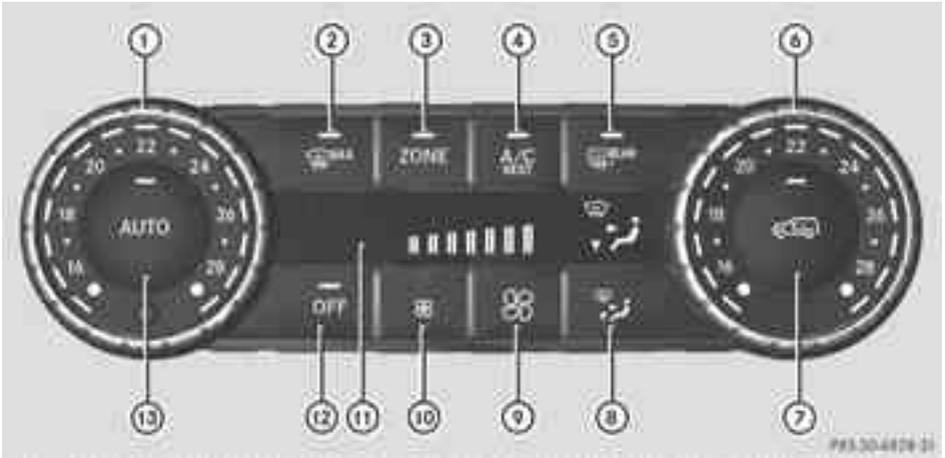

- ① To set the temperature, left (▷ page 131)
- ② To demist the windscreen (▷ page 131)
- ③ To switch the ZONE function on/off (▷ page 131)
- ④ To activate/deactivate cooling with air dehumidification (▷ page 128)
- ⑤ To switch the rear window heating on/off (▷ page 133)
- ⑥ To set the temperature, right (▷ page 131)
- ⑦ To activate/deactivate air-recirculation mode (▷ page 133)
- ⑧ To set the air distribution (▷ page 131)
- ⑨ To increase the airflow (▷ page 131)
- ⑩ To reduce the airflow (▷ page 131)
- ⑪ Display
- ⑫ To switch climate control on/off (▷ page 126)
- ⑬ To set climate control to automatic mode (▷ page 130)

### Information about using THERMATIC automatic climate control

The following contains notes and recommendations on optimum use of THERMATIC automatic climate control.

- Activate climate control using the **AUTO** and **A/C** buttons. The indicator lamps in the **AUTO** and **A/C** buttons light up.
- Set the temperature to 22 °C.
- Only use the demisting function briefly until the windscreen is clear again.

- Only use the air-recirculation mode briefly, e.g. if there are unpleasant outside odours or when in a tunnel. The windows could otherwise mist up, as no fresh air is drawn into the vehicle in air-recirculation mode.
- Use the ZONE function to adopt the temperature settings on the driver's side for the front-passenger side as well. The indicator lamp in the **ZONE** button goes out.

## Operating the climate control system

### Switching climate control on/off

#### Points to observe before use

- i** If climate control is switched off, the air supply and air circulation are also switched off. Only select this setting briefly. Otherwise, the windows may mist up.

#### Switching the air conditioning on

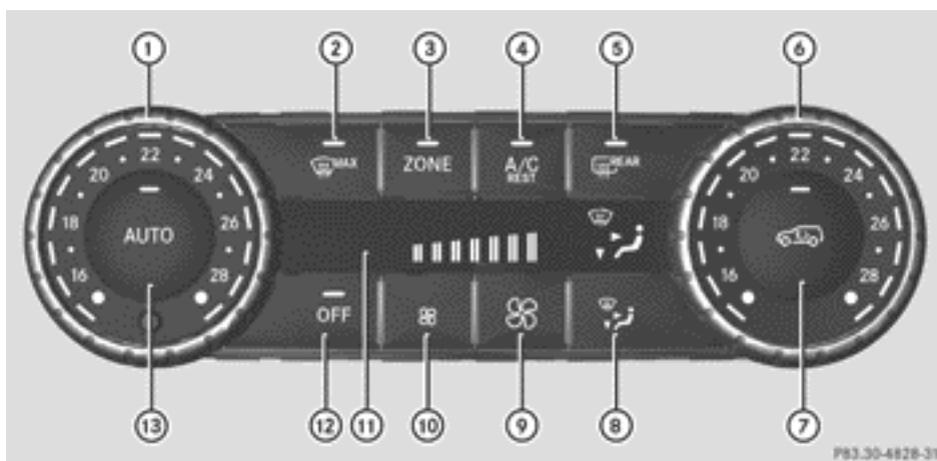

- ① To set the temperature, left (▷ page 131)
- ② To demist the windscreen (▷ page 131)
- ③ To switch the ZONE function on/off (▷ page 131)
- ④ To activate/deactivate cooling with air dehumidification (▷ page 128)
- ⑤ To switch the rear window heating on/off (▷ page 133)
- ⑥ To set the temperature, right (▷ page 131)
- ⑦ To activate/deactivate air-recirculation mode (▷ page 133)
- ⑧ To set the air distribution (▷ page 131)
- ⑨ To increase the airflow (▷ page 131)
- ⑩ To reduce the airflow (▷ page 131)
- ⑪ Display
- ⑫ To switch climate control on/off (▷ page 126)
- ⑬ To set climate control to automatic mode (▷ page 130)

- ▶ Turn the key to position **2** (▷ page 143) in the ignition lock.
  - ▶ Press the **AUTO** button.  
The indicator lamp in the **AUTO** button lights up. Airflow and air distribution are set to automatic mode.
- or
- ▶ Press the **OFF** button.  
The indicator lamp in the **OFF** button goes out. The previous settings are reactivated.

### Switching the climate control off

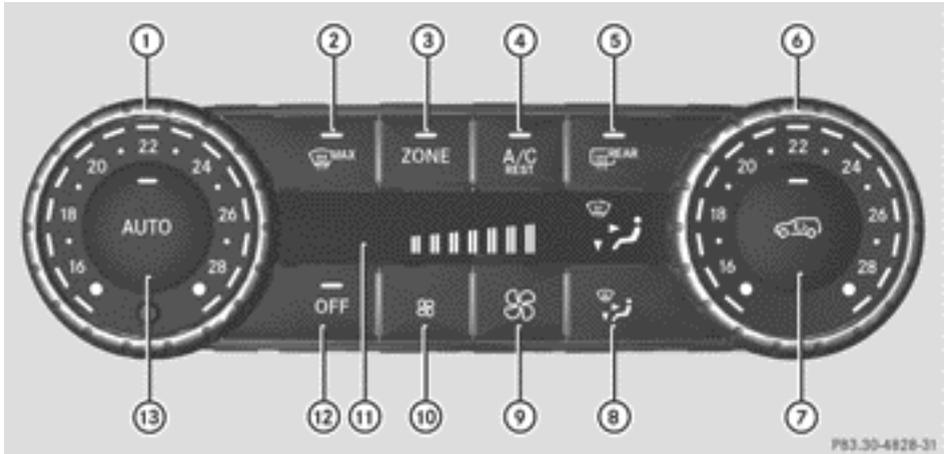

- ① To set the temperature, left (▷ page 131)
- ② To demist the windscreen (▷ page 131)
- ③ To switch the ZONE function on/off (▷ page 131)
- ④ To activate/deactivate cooling with air dehumidification (▷ page 128)
- ⑤ To switch the rear window heating on/off (▷ page 133)
- ⑥ To set the temperature, right (▷ page 131)
- ⑦ To activate/deactivate air-recirculation mode (▷ page 133)
- ⑧ To set the air distribution (▷ page 131)
- ⑨ To increase the airflow (▷ page 131)
- ⑩ To reduce the airflow (▷ page 131)
- ⑪ Display
- ⑫ To switch climate control on/off (▷ page 126)
- ⑬ To set climate control to automatic mode (▷ page 130)

- ▶ Press the **OFF** button.  
The indicator lamp in the **OFF** button lights up.

**Activating/deactivating the cooling with air dehumidification function****Points to observe before use****⚠ WARNING**

If the "cooling with air dehumidification" function is deactivated, the air inside the vehicle will not be cooled (during warm weather) or dehumidified. The windows could mist up more quickly. This may prevent you from observing the traffic conditions, thereby causing an accident.

The cooling with air dehumidification function is only available when the engine is running. The air inside the vehicle is cooled and dehumidified according to the temperature selected. Condensation may drip from the underside of the vehicle when cooling mode is active. This is normal and not a sign that there is a malfunction.

- i** The cooling with air dehumidification function uses refrigerant R 134a. This refrigerant does not contain chlorofluorocarbons, and therefore does not damage the ozone layer.

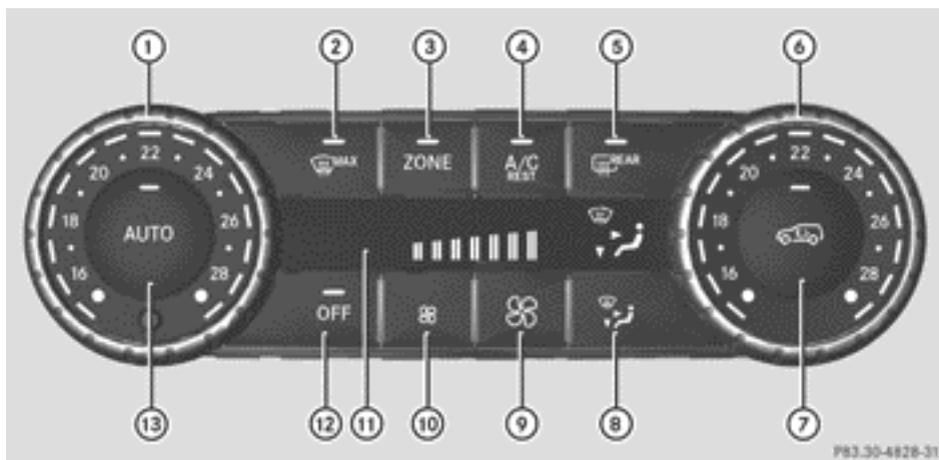
**Activating the cooling with air dehumidification function**

- ① To set the temperature, left (▷ page 131)
- ② To demist the windscreen (▷ page 131)
- ③ To switch the ZONE function on/off (▷ page 131)
- ④ To activate/deactivate cooling with air dehumidification (▷ page 128)
- ⑤ To switch the rear window heating on/off (▷ page 133)
- ⑥ To set the temperature, right (▷ page 131)
- ⑦ To activate/deactivate air-recirculation mode (▷ page 133)
- ⑧ To set the air distribution (▷ page 131)
- ⑨ To increase the airflow (▷ page 131)
- ⑩ To reduce the airflow (▷ page 131)
- ⑪ Display

- ⑫ To switch climate control on/off (▷ page 126)
- ⑬ To set climate control to automatic mode (▷ page 130)

► Press the  button.

The indicator lamp in the  button lights up.

### Deactivating the cooling with air dehumidification function

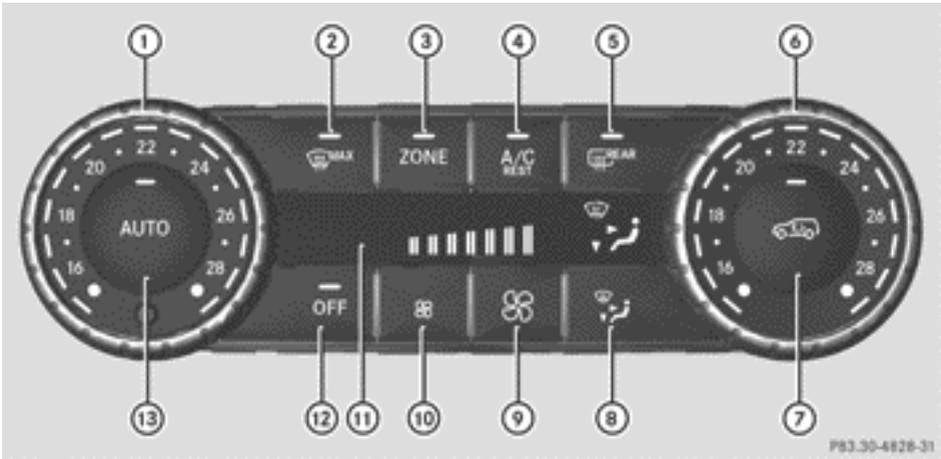

- ① To set the temperature, left (▷ page 131)
- ② To demist the windscreen (▷ page 131)
- ③ To switch the ZONE function on/off (▷ page 131)
- ④ To activate/deactivate cooling with air dehumidification (▷ page 128)
- ⑤ To switch the rear window heating on/off (▷ page 133)
- ⑥ To set the temperature, right (▷ page 131)
- ⑦ To activate/deactivate air-recirculation mode (▷ page 133)
- ⑧ To set the air distribution (▷ page 131)
- ⑨ To increase the airflow (▷ page 131)
- ⑩ To reduce the airflow (▷ page 131)
- ⑪ Display
- ⑫ To switch climate control on/off (▷ page 126)
- ⑬ To set climate control to automatic mode (▷ page 130)

► Press the  button.

The indicator lamp in the  button goes out. The cooling with air dehumidification function has a delayed switch-off feature.

## Problems with the cooling with air dehumidification function

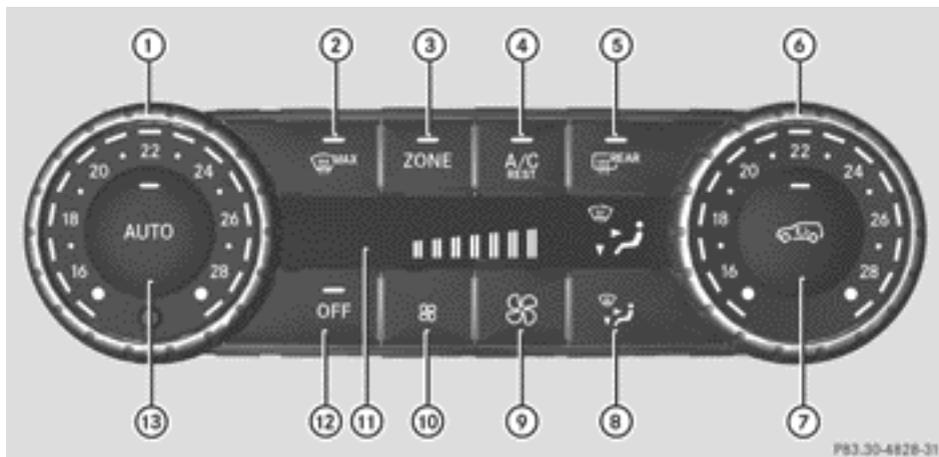

- ① To set the temperature, left (▷ page 131)
- ② To demist the windscreen (▷ page 131)
- ③ To switch the ZONE function on/off (▷ page 131)
- ④ To activate/deactivate cooling with air dehumidification (▷ page 128)
- ⑤ To switch the rear window heating on/off (▷ page 133)
- ⑥ To set the temperature, right (▷ page 131)
- ⑦ To activate/deactivate air-recirculation mode (▷ page 133)
- ⑧ To set the air distribution (▷ page 131)
- ⑨ To increase the airflow (▷ page 131)
- ⑩ To reduce the airflow (▷ page 131)
- ⑪ Display
- ⑫ To switch climate control on/off (▷ page 126)
- ⑬ To set climate control to automatic mode (▷ page 130)

When you press the  button, the indicator lamp in the button flashes three times or remains off. You can no longer switch on the cooling with air dehumidification function.

► Visit a qualified specialist workshop.

### Setting climate control to automatic mode

In automatic mode, the set temperature is maintained at a constant level. The system automatically regulates the temperature of the dispensed air, the airflow and the air distribution.

Automatic mode will achieve optimal operation if cooling with air dehumidification is also activated. If desired, cooling with air dehumidification can be deactivated.

- ▶ Turn the key to position **2** (▷ page 143) in the ignition lock.
- ▶ Set the desired temperature.
- ▶ **To switch on:** press the  button. The indicator lamp in the  button lights up. Automatic air distribution and airflow are activated.
- ▶ **To switch off:** press the  button.

or

- ▶ Press the  or  button. The indicator lamp in the  button goes out.

### Setting the temperature

You can set the temperature separately for the driver's and front-passenger sides with controls ① or ⑥ (▷ page 125).

- ▶ Turn the key to position **2** (▷ page 143) in the ignition lock.
- ▶ Set control ① or ⑥ (▷ page 125) to the desired temperature. Only change the temperature setting in small increments. Start at 22 °C.

### Setting the air distribution

- ▶ Turn the key to position **2** (▷ page 143) in the ignition lock.
- ▶ Press the  button repeatedly until the desired symbol appears in the display.

-  Directs the airflow through the centre vents
-  Directs the airflow through the footwell air vents
-  Directs the airflow through the centre and footwell vents
-  Directs the airflow through the demister vents
-  Directs the airflow through the demister vents and the footwell.

### Setting the airflow

- ▶ Turn the key to position **2** (▷ page 143) in the ignition lock.
- ▶ **To increase:** press the  button.
- ▶ **To reduce:** press the  button.

**i** The airflow from the rear-compartment vents and the centre vents is the same.

### Activating/deactivating the ZONE function

- ▶ **To switch on:** press the  button. The indicator lamp in the  button lights up.
- i** The temperature setting for the driver's side is not adopted for the front-passenger side and the rear compartment. The temperature for the front-passenger side and the rear compartment must be set separately.
- ▶ **To switch off:** press the  button. The indicator lamp in the  button goes out.
- i** The temperature setting for the driver's side is adopted for the front-passenger side and the rear compartment.

### Demisting the windscreen

You can use this function to demist the windscreen or to demist the inside of the windscreen and the side windows.

- i** You should only select the demisting function until the windscreen is clear again.
- ▶ Turn the key to position **2** (▷ page 143) in the ignition lock.
- ▶ **To activate:** press the  button. The indicator lamp in the  button lights up.

The climate control system switches to the following functions:

- cooling with air dehumidification (only with engine running)
- high airflow (depending on the outside temperature)
- high temperature (depending on the outside temperature)
- air distribution to the windscreen and front side windows
- air-recirculation mode off

▶ **To deactivate:** press the  button. The indicator lamp in the  button goes out. The previous settings are reactivated. The cooling with air dehumidification function remains on. Air-recirculation mode remains deactivated.

or

▶ Press the **AUTO** button. The indicator lamp in the  button goes out. Airflow and air distribution are set to automatic mode.

or

▶ Turn controls ① or ⑥ clockwise or anti-clockwise (▷ page 125).

or

▶ Press the  or  button.

### Demisting the windows

#### Windows misted up on the inside

- ▶ Activate the  cooling with air dehumidification function.
- ▶ Activate automatic mode **AUTO**.
- ▶ If the windows continue to mist up, activate the demisting function (▷ page 131).
- ❗ You should only select this setting until the windscreen is clear again.

#### Windows misted up on the outside

- ▶ Switch on the windscreen wipers (▷ page 119).
- ▶ Press the  button repeatedly until the  or  symbol appears in the display.
- ❗ You should only select this setting until the windscreen is clear again.

#### Switching the windscreen heating on/off



- ▶ Turn the key to position **2** (▷ page 143) in the ignition lock.
- ▶ **To switch on:** press button ②. Indicator lamp ① lights up.
- ▶ **To switch off:** press button ②. Indicator lamp ① goes out.
- ❗ At outside temperatures above 10 °C, the windscreen heating cannot be activated. Indicator lamp ① lights up briefly when you attempt to activate it and then goes out again.
- ❗ The windscreen heating has a high current draw. You should therefore switch it off as soon as the windscreen is clear. The windscreen heating otherwise switches itself off automatically after 10 minutes.
- ❗ If the battery voltage is too low, the windscreen heating may switch off. If the windscreen heating is automatically deactivated, indicator lamp ① flashes. The windscreen heating will automatically switch

back on as soon as there is sufficient voltage.

### Switching the rear window heating on/off

#### Switching on/off

##### WARNING

Clear all windows of ice or snow before setting off. Otherwise, impaired visibility could endanger you and others.

- ▶ Turn the key to position **2** (▷ page 143) in the ignition lock.
- ▶ **USA only:** press the  button. The indicator lamp in the  button lights up or goes out.
- i** The rear window heating has a high current draw. You should therefore switch it off as soon as the window is clear. It only switches itself off automatically after a few minutes.
- i** If the battery voltage is too low, the rear window heating may switch off.

#### Problems with the rear window heating

If the indicator lamp in the  rear window heating button flashes, the on-board voltage is too low. The rear window heating has switched off prematurely or cannot be activated.

- ▶ Switch off any consumers that are not required, e.g. reading lamps or interior lighting. When the battery is sufficiently charged, the rear window heating is activated again automatically.

### Activating/deactivating air-recirculation mode

##### WARNING

Only switch over to air-recirculation mode briefly at low outside temperatures. Otherwise, the windows could mist up, thus impairing visibility and endangering yourself and others. This may prevent you from observing the traffic conditions, thereby causing an accident.

- ▶ Turn the key to position **2** (▷ page 143) in the ignition lock.
- ▶ **To switch on:** press the  button. The indicator lamp in the  button lights up.
  - i** Air-recirculation mode is automatically activated at high levels of pollution or at high outside temperatures. When air-recirculation mode is activated automatically, the indicator lamp in the  button is not lit. Outside air is added after approximately 30 minutes.
- ▶ **To deactivate:** press the  button. The indicator lamp in the  button goes out.
  - i** Air-recirculation mode switches off automatically:
    - after approximately five minutes at outside temperatures below approximately 5 °C
    - after approximately five minutes if cooling with air dehumidification is deactivated
    - after approximately 30 minutes at outside temperatures above approximately 5 °C

### Activating/deactivating the residual heat function

It is possible to make use of the residual heat of the engine to continue heating the station-

any vehicle for up to 30 minutes after the engine has been switched off. The heating time depends on the coolant temperature and on the interior temperature that has been set.

**i** The blower will run at a low speed regardless of the airflow setting.

**i** If you activate the residual heat function at high temperatures, only the ventilation will be activated.

► Turn the key to position **0** (▷ page 143) in the ignition lock or remove it.

► **To activate:** press the  button. The indicator lamp in the  button lights up.

► **To deactivate:** press the  button. The indicator lamp in the  button goes out.

**i** Residual heat is deactivated automatically:

- after approximately 30 minutes
- when the ignition is switched on
- if the battery voltage drops
- if the coolant temperature is too low

## Auxiliary heating

### Important safety notes

#### WARNING

Exhaust fumes are produced when the auxiliary heating is in operation. Inhaling these exhaust fumes can be poisonous. You should therefore switch off the auxiliary heating in confined spaces without an extraction system, e.g. a garage.

#### WARNING

When operating the auxiliary heating parts of the vehicle can get very hot. Make sure that the exhaust system does not under any circumstances come into contact with easily ignitable material such as dry grass or fuels. The material could otherwise ignite and set

the vehicle alight. Choose your parking spot accordingly.

Operating the auxiliary heating is thus prohibited at filling stations or when your vehicle is being refuelled. You must therefore switch off the auxiliary heating at filling stations.

**!** Operating the auxiliary heating/ventilation draws on the vehicle battery. After you have heated or ventilated the vehicle a maximum of two times, drive for a longer distance.

**i** Switch the auxiliary heating on regularly once a month for approximately ten minutes.

The auxiliary heating heats the air in the vehicle interior without using the heat of the running engine. The auxiliary heating is operated directly using the vehicle's fuel. For this reason, the tank content must be at least at reserve fuel level to ensure that the auxiliary heating functions.

The auxiliary heating/ventilation automatically adjusts to changes in temperature and weather conditions. For this reason, the auxiliary heating could switch from ventilation mode to heating mode or from heating mode to ventilation mode.

You cannot use the auxiliary ventilation to cool the vehicle interior to a temperature lower than the outside temperature.

### Before switching on

- Turn the key to position **2** (▷ page 143) in the ignition lock.
- Set the temperature.

The auxiliary heating/ventilation can be activated even when climate control is set to manual. Optimum comfort can be attained when the system is set to automatic mode. Set the temperature to 22 °C.

The auxiliary heating/ventilation can be activated or deactivated using the remote control or the button on the centre console.

The on-board computer can be used to specify up to three departure times, one of which may be preselected (▷ page 223).

### Switching the auxiliary heating/ventilation on/off using the centre console button

#### Auxiliary heating overview



① To activate/deactivate the auxiliary heating

The colours of the indicator lamps on the button have the following meanings:

- Blue Auxiliary ventilation switched on
- Red Auxiliary heating switched on
- Yellow Departure time preselected (▷ page 223)

#### Switching on the auxiliary heating/ventilation



① To activate/deactivate the auxiliary heating

- ▶ Press button ①.  
The red or blue indicator lamp in button ① lights up.

#### Switching off the auxiliary heating/ventilation



① To activate/deactivate the auxiliary heating

- ▶ Press button ①.  
The red or blue indicator lamp in button ① goes out.

### Switching the auxiliary heating/ventilation on/off using the remote control

#### Auxiliary heating remote control

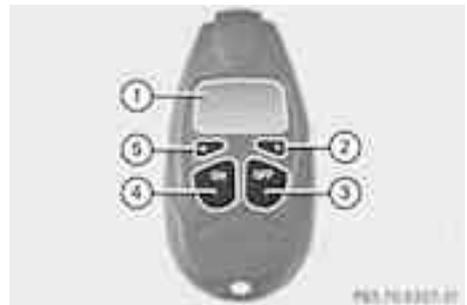

- ① Display
- ②  To check the status/set the departure time
- ③ **OFF** To switch off the auxiliary heating/ventilation

- ④  To switch on the auxiliary heating/ventilation
- ⑤  To check the status/set the departure time

Your vehicle comes with one remote control. You may use one additional remote control for your vehicle. For more information, please contact a qualified specialist workshop.

The remote control has a maximum range of approximately 300 metres. This range is reduced by:

- sources of radio interference
- solid objects between the remote control and the vehicle
- the remote control being in an unfavourable position in relation to the vehicle
- transmitting from an enclosed space

**i** The optimum range can be achieved if you hold the remote control vertically, pointing upwards when you press one of the buttons.

**Switching on the auxiliary heating/ventilation**

- ▶ Press the  button.  
ON is shown in the remote control display.

**Switching off the auxiliary heating/ventilation**

- ▶ Press the  button.  
OFF is shown in the remote control display.

**Checking the status of the auxiliary heating/ventilation**

- ▶ Press the  or  button.

The following messages may appear in the display:

Display	Meaning
	The auxiliary heating/ventilation is switched off.

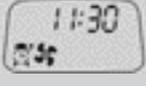
	The auxiliary ventilation is switched on. The number in the display shows the remaining time (in minutes) for the auxiliary ventilation.
	The auxiliary heating is switched on. The number in the display shows the remaining time (in minutes) for the auxiliary heating.
	A departure time has been activated. The departure time appears in the display.
	A departure time has been activated. The auxiliary ventilation is currently selected. The departure time appears in the display.
	A departure time has been activated. The auxiliary heating is currently selected. The departure time appears in the display.

**Setting the departure time**

- ▶ Press the  or  button repeatedly until the time to be changed appears in the display.
  - ▶ Press the  and  buttons simultaneously.  
The  symbol in the remote control display flashes.
  - ▶ Press the  or  button to set the desired departure time.
- i** The longer you press the  or  button, the faster the time changes.

- ▶ Press the **ON** and **OFF** buttons simultaneously.  
The new departure time is stored.

**Activating the set departure time**

- ▶ Press the **<** or **>** button repeatedly until the desired departure time appears in the display.
- ▶ Press the **ON** button.  
The  symbol and the departure time appear in the display.

**Deactivating a set departure time**

- ▶ Press the **<** or **>** button.  
The status of the auxiliary heating is shown in the display.
- ▶ Press the **>** button.  
The first departure time stored appears in the display.
- ▶ Press the **OFF** button.  
The display message **OFF** appears in the display.

**Replacing the batteries in the remote control**

 **WARNING**

Batteries contain poisonous substances. Swallowing/ingesting batteries can result in serious personal injury or death. Always keep batteries away from children. If a battery is swallowed, seek immediate medical attention.

 **Environmental note**



Batteries contain pollutants. It is illegal to dispose of them with the household rubbish. They must be collected separately and disposed of in an environmentally responsible recycling system.



Dispose of batteries in an environmentally responsible manner. Take discharged batteries to a qualified spe-

cialist workshop or to a collection point for used batteries.



You require a 6-V pin battery, type 2CR11108.

- ▶ Prise apart the side arms of battery cover **2** and pull off battery cover **2**.
- ▶ Remove battery **1**.
- ▶ Insert the new battery. Observe the polarity signs on the back of the remote control when doing so.
- ▶ Slide battery cover **2** back onto the remote control.
- ▶ Use the remote control to check the vehicle's auxiliary heating functions.

Problems with the auxiliary heating/ventilation

Display messages	Possible causes/consequences and ► Solutions
<p>(↑↑) FAIL</p>	<p>The signal transmission between the transmitter and the vehicle is faulty.</p> <ul style="list-style-type: none"> <li>► Change your position in relation to the vehicle, moving closer if necessary.</li> <li>► Make another attempt to switch the auxiliary heating on or off using the remote control.</li> </ul>
<p>FAIL</p> 	<p>This display message will only appear if you attempt to activate the auxiliary heating.</p> <p>there is not enough fuel in the fuel tank, or the auxiliary heating is faulty.</p> <ul style="list-style-type: none"> <li>► Refuel at the nearest filling station.</li> <li>► Make another attempt to switch on the auxiliary heating using the remote control.</li> <li>► Have the auxiliary heating checked at a qualified specialist workshop.</li> </ul>
<p>FAIL</p>	<p>This display message may appear if you attempt to activate the auxiliary heating or during a status query.</p> <p>If the auxiliary heating does not switch on or has switched off while running, this has occurred due to one of the following reasons:</p> <ul style="list-style-type: none"> <li>• the auxiliary heating was started more than twice when the engine was switched off.</li> <li>• the starter battery is not sufficiently charged.</li> <li>• there is too little fuel in the fuel tank.</li> <li>• the auxiliary heating is faulty.</li> </ul> <p><b>If the auxiliary heating was switched on more than twice:</b></p> <ul style="list-style-type: none"> <li>► Switch on the engine and let it run for more than 10 seconds.</li> <li>► Make another attempt to switch on the auxiliary heating using the remote control.</li> </ul> <p><b>If the starter battery is not sufficiently charged:</b></p> <ul style="list-style-type: none"> <li>► Charge the starter battery.</li> <li>► Make another attempt to switch on the auxiliary heating using the remote control.</li> </ul> <p><b>If there is not enough fuel:</b></p> <ul style="list-style-type: none"> <li>► Refuel at the nearest filling station.</li> <li>► Make another attempt to switch on the auxiliary heating using the remote control.</li> </ul>

Display messages	Possible causes/consequences and ► Solutions
	<b>If the auxiliary heating is faulty:</b> <ul style="list-style-type: none"> <li>► Have the auxiliary heating checked at a qualified specialist workshop.</li> </ul>

## Adjusting the air vents

### Important safety notes

#### WARNING

Very hot or very cold air can flow from the air vents. This could cause burns or frostbite to bare skin in the immediate vicinity of the vents. Keep bare skin away from these air outlets. If necessary, direct the airflow away to a different area of the vehicle interior.

### General notes

In order to ensure the direct flow of fresh air through the air vents into the vehicle interior, please observe the following notes:

- keep the air inlet grille on the bonnet free of blockages, such as ice, snow or leaves.
- never cover the vents or ventilation grilles in the vehicle interior.

- i** For virtually draught-free ventilation, adjust the sliders of the air vents to the centre position.
- i** If the automatic climate control constantly differs from the set temperature or if undesired draughts are noticeable, proceed as follows:
  - Open the side air vents
  - Open the centre air vents
  - Open the rear air vents
  - Set the temperature to 22 °C.  
The automatic climate control adjusts itself to the set temperature.

## Setting the centre air vents



Centre air vents

- ① Centre air vent, left
- ② Centre air vent, right
- ③ Centre vent thumbwheel, right
- ④ Centre vent thumbwheel, left

► **To open/close:** turn thumbwheels ③ and ④ to the right or left.

## Setting the side air vents



Side air vents

- ① Side air vent
- ② Swivelling side air vent
- ③ Control for side air vent

- ▶ **To open/close:** turn thumbwheel ③ to the left or right.

### Setting the rear-compartment air vents

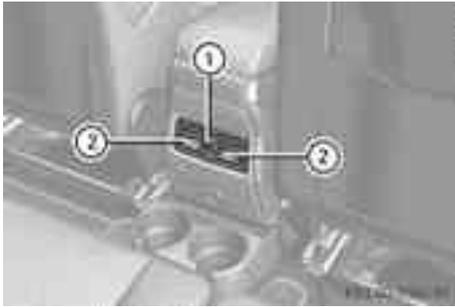

- ▶ **To open/close:** turn thumbwheel ① up or down.
- ▶ **To set the air direction:** move slider ② for the corresponding rear-compartment air vent to the left, right, up or down.

Useful information .....	142
Running-in notes .....	142
Driving .....	142
Automatic transmission .....	149
Refuelling .....	156
Parking .....	163
Driving tips .....	164
Driving systems .....	173
Off-road driving systems .....	201
Towing a trailer .....	206

### Useful information

- i** This Owner's Manual describes all models, series and optional equipment for your vehicle that were available at the time of going to press. Country-specific differences are possible. Note that your vehicle may not be fitted with all features described. This is also the case for systems and functions relevant to safety.
- i** Read the information on qualified specialist workshops: (▷ page 22).

### Running-in notes

#### Important safety notes

New brake pads/brake pads and discs that have been replaced only achieve optimum braking effect after several hundred kilometres of driving. Compensate for the reduced braking effect by applying greater force to the brake pedal.

#### The first 1,500 km

If you treat the engine with sufficient care from the very start, you will be rewarded with excellent performance for the remainder of the engine's life.

- Drive at varying vehicle speeds and engine speeds for the first 1,500 km.
- Avoid overstraining the vehicle during this period, e.g. driving at full throttle.
- Change gear in good time, before the rev counter needle is  $\frac{2}{3}$  of the way to the red area of the rev counter.
- Do not shift down a gear manually in order to brake.
- Try to avoid depressing the accelerator pedal beyond the point of resistance (kick-down).
- The shift ranges **3**, **2** or **1** should only be engaged when driving slowly, e.g. when driving in mountainous terrain.

After 1,500 km, you may gradually bring the vehicle up to full road and engine speeds.

Additional running-in notes for AMG vehicles:

- Do not drive at speeds above 140 km/h for the first 1,500 km.
  - Only allow the engine to reach a maximum engine speed of 4,500 rpm briefly.
  - Avoid driving off-road before the differential oil change at 3,000 km.
  - Drive the vehicle mainly in drive program **C** for the first 1,500 km.
- i** You should also observe these notes on running in if the engine or parts of the drive train on your vehicle have been replaced.

#### AMG vehicles with rear axle differential lock

To improve the protection of the differential, change the oil after a run-in distance of 3,000 km. This oil change will lengthen the service life of the differential. Have the oil change carried out at a qualified specialist workshop.

### Driving

#### Important safety notes

##### WARNING

Objects in the driver's footwell can restrict the pedal travel or obstruct a depressed pedal. The operating and road safety of the vehicle is jeopardised. There is a risk of an accident. Make sure that all objects in the vehicle are stowed correctly, and that they cannot enter the driver's footwell. Fit the floor mats securely and as specified in order to ensure sufficient clearance for the pedals. Do not use loose floor mats.

**⚠ WARNING**

Unsuitable footwear can hinder correct usage of the pedals, e.g.:

- shoes with thick soles
- shoes with high heels
- slippers

There is a risk of an accident.

Wear suitable footwear to ensure correct usage of the pedals.

**⚠ WARNING**

If you switch off the ignition while driving, safety-relevant functions are only available with limitations, or not at all. This could affect, for example, the power steering and the brake boosting effect. You will require considerably more effort to steer and brake. There is a risk of an accident.

Do not switch off the ignition while driving.

**⚠ WARNING**

If the parking brake has not been fully released when driving, the parking brake can:

- overheat and cause a fire
- lose its hold function.

There is a risk of fire and an accident. Release the parking brake fully before driving off.

**!** Warm up the engine quickly. Do not use the engine's full performance until it has reached operating temperature.

Only set the automatic transmission to the respective drive positions when the vehicle is stationary.

Where possible, avoid spinning the drive wheels when pulling away on slippery roads. Otherwise, you could damage the drive train.

**!** Avoid high engine speeds when the engine is cold. The engine's service life could otherwise be significantly shortened. Do not use the engine's full performance until it has reached operating temperature.

**!** **AMG vehicles:** at low engine oil temperatures (below +20 °C), the maximum engine speed is restricted in order to protect the engine. To protect the engine and maintain smooth engine operation, avoid driving at full throttle when the engine is cold.

**Key positions**

- 0** To remove the key
- 1** Power supply for some consumers, such as the windscreen wipers
- 2** Ignition (power supply for all consumers) and drive position
- 3** To start the engine

**i** The indicator and warning lamps light up in the instrument cluster when you switch on the ignition. They go out when the engine is running. This shows that the indicator and warning lamps for each system are operational.

**i** You can only remove the key if:

- the key is in position **0** in the ignition lock.
- the automatic transmission selector lever is in **P**.

## Starting the engine

### Important safety notes

#### WARNING

Combustion engines emit poisonous exhaust gases such as carbon monoxide. Inhaling these exhaust gases leads to poisoning. There is a risk of fatal injury. Therefore never leave the engine running in enclosed spaces without sufficient ventilation.

- !** Do not depress the accelerator pedal when starting the engine.

### Starting procedure

- ▶ Shift the automatic transmission to position **P**.  
The transmission position display in the multifunction display shows **P**.
- i** You can also start the engine when the automatic transmission is in position **N**.
- i** For further information about the automatic transmission, see (▷ page 149).
- i** If you depress the brake when starting the engine, pedal travel is unusually long and there is less pedal resistance.
- ▶ Make sure that the parking brake is applied.
- ▶ **To start a petrol engine:** turn the key to position **3** in the ignition lock (▷ page 143) and release it as soon as the engine is running.
- ▶ **To start a diesel engine:** turn the key to position **2** in the ignition lock (▷ page 143).  
The  preglow indicator lamp in the instrument cluster lights up.
- ▶ When the  preglow indicator lamp goes out, turn the key to position **3** (▷ page 143) and release it as soon as the engine is running.
- i** You can start the engine without preglow if the engine is warm.

- i** You can also use the touch-start function. To do this, turn the key to position **3** (▷ page 143) and release it immediately. The engine then starts automatically.

## Pulling away

### Automatic transmission

#### WARNING

If the engine speed is above the idling speed and you engage transmission position **D** or **R**, the vehicle could pull away suddenly. There is a risk of an accident.

When engaging transmission position **D** or **R**, always firmly depress the brake pedal and do not simultaneously accelerate.

- !** Only shift the automatic transmission to reverse gear **R** or park position **P** when the vehicle is stationary. Otherwise, the automatic transmission could be damaged.
- !** If a warning tone sounds and the **Release park. brake** message appears in the multifunction display, the parking brake is still applied. Release the parking brake.
- ▶ Depress the brake pedal and keep it depressed.
- ▶ Shift the automatic transmission to position **D** or **R**.
- i** Before driving off, wait until the gear change is fully completed.
- ▶ Release the parking brake (▷ page 164).
- ▶ Release the brake pedal.
- ▶ Carefully depress the accelerator pedal.
- i** It is only possible to shift the automatic transmission from position **P** to a different position if you depress the brake pedal. Only then is the selector lever lock released.
- i** The vehicle locks centrally once you have pulled away. The locking knobs in the doors drop down.

You can open the doors from the inside at any time.

You can also deactivate the automatic locking feature (▷ page 223).

- i** Upshifts take place at higher engine speeds after a cold start. This helps the catalytic converter to reach its operating temperature more quickly.

### Hill start assist

#### WARNING

After a short time, hill start assist will no longer brake your vehicle and it could roll away. There is a risk of an accident and injury.

Therefore, quickly move your foot from the brake pedal to the accelerator pedal. Never leave the vehicle when it is held by hill start assist.

Hill start assist helps you when pulling away forwards or in reverse on an uphill gradient. It holds the vehicle for a short time after you have removed your foot from the brake pedal. This gives you enough time to move your foot from the brake pedal to the accelerator pedal and depress it before the vehicle begins to roll.

▶ Take your foot off the brake pedal.

- i** Once you have taken your foot off the brake pedal, the vehicle is held for around one second.

▶ Pull away.

Hill start assist will not function if:

- you are pulling away on a level road or a downhill gradient.
- the transmission is in position **N**.
- the parking brake is applied.
- ESP® is malfunctioning.

### ECO start/stop function (AMG vehicles)

#### Important safety notes

#### WARNING

If the engine is switched off automatically and you exit the vehicle, the engine is restarted automatically. The vehicle may begin moving. There is a risk of accident and injury.

If you wish to exit the vehicle, always turn off the ignition and secure the vehicle against rolling away.

#### General notes

The ECO start/stop function is only available for the G 63 AMG.

The ECO start/stop function switches the engine off automatically if the vehicle stops moving.

When pulling away again, the engine starts automatically. The ECO start/stop function thereby helps you to reduce the fuel consumption and emissions of your vehicle.

The ECO start/stop function is activated each time the engine is switched on.

The ECO start/stop function is only available in drive program **C**.

The system is operational when the **ECO** symbol is shown in green in the multifunction display.

The system is operational if all conditions for automatic engine switch-off have been fulfilled (▷ page 146) and the **ECO** symbol is shown in green in the multifunction display.

In addition, the **Stop/Start active** message is shown in the AMG menu in the multifunction display.

If not all conditions for automatic engine switch-off are fulfilled (▷ page 146), the **ECO** symbol is shown in yellow in the multifunction display.

In addition, the **Stop/Start inactive** message is shown in the AMG menu in the multifunction display.

If the ECO start/stop function has been manually deactivated (> page 146) or if a malfunction has caused the system to be deactivated, the **ECO** symbol is not displayed.

The **Stop/Start active** or **Stop/Start inactive** message in the AMG menu in the multifunction display goes out.

### Activating/deactivating the ECO start/stop function

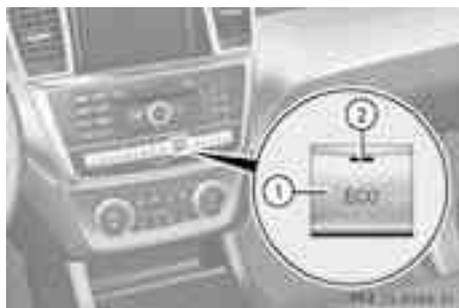

ECO button

► **To switch off:** in drive program **C**, press button ①.

or

► Switch to drive program **S** or **M** (> page 152).

Indicator lamp ② on button ① and the **ECO** symbol in the multifunction display go out.

The **Stop/Start active** or **Stop/Start inactive** message in the AMG menu in the multifunction display goes out.

► **To switch on:** press button ①.

Indicator lamp ② lights up. If drive program **S** or **M** is active, the automatic transmission switches to drive program **C**.

If all conditions for automatic engine switch-off (> page 146) are fulfilled, the **ECO** symbol is shown in green in the multifunction display. In addition, the **Stop/Start active** message is shown in the AMG menu in the multifunction display.

If not all conditions for automatic engine switch-off (> page 146) are fulfilled, the

**ECO** symbol is not shown. If this is the case, the ECO start/stop function is not available. In addition, the **Stop/Start inactive** message is shown in the AMG menu in the multifunction display.

❗ If indicator lamp ② is off, the ECO start/stop function has been deactivated manually or as the result of a malfunction. The engine will then not be switched off automatically when the vehicle stops.

❗ The stop/start function is automatically activated each time you start the engine with the ignition key.

### Automatic engine switch-off

If the vehicle is braked to a standstill in transmission position **D** or **N**, the ECO start/stop function switches off the engine automatically.

The ECO start/stop function is operational and the **ECO** symbol is displayed in green in the multifunction display if:

- the indicator lamp in the ECO button is lit green
- none of the off-road programs are selected
- the vehicle is stationary
- the outside temperature is within the comfort range
- the engine is at normal operating temperature
- the set temperature for the vehicle interior has been reached
- the battery is sufficiently charged
- the system detects that the windscreen is not misted up when the air-conditioning system is switched on
- the bonnet is closed
- the driver's door is closed and the driver's seat belt is fastened

If not all conditions for automatic engine switch-off are fulfilled, the **ECO** symbol is shown in yellow.

In addition, the **Stop/Start inactive** message is shown in the AMG menu in the multifunction display.

- i** If you shift the transmission from **R** to **D**, the ECO start/stop function is available again once the **ECO** symbol reappears in green in the multifunction display.
- i** The engine can be automatically switched off an unlimited number of times.
- i** You can also activate the HOLD function when the vehicle is stationary if the engine has been switched off automatically. It is then not necessary to continue applying the brakes during the automatic stop phase. When you depress the accelerator pedal, the engine starts automatically and the braking effect of the HOLD function is deactivated. Depress the accelerator pedal gently, as the engine must be started first.
- i** During automatic engine switch-off, the climate control system only operates at a reduced capacity. If you require full climate control capacity, the ECO start/stop function can be deactivated by pressing the ECO button (> page 146).

## Automatic engine start

The engine is started automatically if:

- In general:
  - you switch off the ECO start/stop function by pressing the ECO button.
  - you release the brakes when in transmission position **D** or **N**, when the HOLD function is inactive.
- By the driver:
  - you release the brakes when in transmission position **D** or **N**.
  - you depress the accelerator pedal.
  - you engage reverse gear **R**.
  - you move the transmission out of position **P**.
  - you switch to drive program **S** or **M**.
  - you unfasten your seat belt or open the driver's door.
- By the system:
  - the vehicle starts to roll.
  - the brake system requires this.
  - the temperature in the vehicle interior deviates from the set range.
  - the system detects moisture on the windscreen when the air-conditioning system is switched on.
  - the battery's charge status is too low.
- i** Shifting the transmission to position **P** does not start the engine.

Problems with the engine	
Problem	Possible causes/consequences and ► Solutions
The engine does not start. The starter motor can be heard.	<ul style="list-style-type: none"> <li>• There is a malfunction in the engine electronics.</li> <li>• There is a malfunction in the fuel supply.</li> </ul> <ul style="list-style-type: none"> <li>► Turn the key back to position <b>0</b> in the ignition lock before attempting to start the engine again.</li> <li>► Try to start the engine again (&gt; page 144). Avoid excessively long and frequent attempts to start the engine, as this (&gt; page 143) will drain the battery.</li> </ul> <p>If the engine does not start after several attempts:</p> <ul style="list-style-type: none"> <li>► Consult a qualified specialist workshop.</li> </ul>
The engine does not start. The starter motor can be heard. The yellow reserve fuel warning lamp is lit and the needle of the fuel gauge display shows <b>0</b> .	<p>The fuel tank is empty.</p> <ul style="list-style-type: none"> <li>► Refuel the vehicle.</li> <li>► <b>Vehicles with a diesel engine:</b> bleed the fuel system (&gt; page 159).</li> </ul>
The engine does not start. You cannot hear the starter motor.	<p>The on-board voltage is too low because the battery is too weak or discharged.</p> <ul style="list-style-type: none"> <li>► Jump-start the vehicle (&gt; page 309).</li> </ul> <p>If the engine does not start despite attempts to jump-start it:</p> <ul style="list-style-type: none"> <li>► Consult a qualified specialist workshop.</li> </ul>
	<p>The starter motor was exposed to a thermal load that was too high.</p> <ul style="list-style-type: none"> <li>► Allow the starter motor to cool down for approximately two minutes.</li> <li>► Try to start the engine again.</li> </ul> <p>If the engine still does not start:</p> <ul style="list-style-type: none"> <li>► Consult a qualified specialist workshop.</li> </ul>
Vehicles with a petrol engine: The engine is not running smoothly and is misfiring.	<p>There is a malfunction in the engine electronics or in a mechanical component of the engine management system.</p> <ul style="list-style-type: none"> <li>► Only depress the accelerator pedal slightly. Otherwise, non-combusted fuel may get into the catalytic converter and damage it.</li> <li>► Have the cause rectified immediately at a qualified specialist workshop.</li> </ul>

Problem	Possible causes/consequences and ► Solutions
<p>The coolant temperature display is showing more than 120 °C. A display message may also appear in the multifunction display and a warning tone may sound.</p>	<p>The coolant level is too low. The coolant is too hot and the engine is no longer being cooled sufficiently.</p> <ul style="list-style-type: none"> <li>► Stop as soon as possible and allow the engine and the coolant to cool down.</li> <li>► Check the coolant level (► page 289). Observe the warning notes as you do so and top up the coolant if necessary.</li> </ul> <p>If the coolant level is correct, the radiator fan may be faulty. The coolant is too hot and the engine is no longer being cooled sufficiently.</p> <ul style="list-style-type: none"> <li>► If the coolant temperature is below 120 °C, you can continue driving to the nearest qualified specialist workshop.</li> <li>► Avoid heavy loads on the engine as you do so, e.g. driving in mountainous terrain and stop-start traffic.</li> </ul>

## Automatic transmission

### Important safety notes

#### WARNING

If the engine speed is above the idling speed and you engage transmission position **D** or **R**, the vehicle could pull away suddenly. There is a risk of an accident.

When engaging transmission position **D** or **R**, always firmly depress the brake pedal and do not simultaneously accelerate.

- i** Bear in mind that the power transmission between the engine and the transmission is interrupted when the engine is switched off. Therefore, to prevent the vehicle from rolling away, shift the automatic transmission to position **P** and apply the parking brake when the engine is switched off and the vehicle is stationary.

### Selector lever

#### Overview of transmission positions

- !** If the engine speed is too high or if the vehicle is rolling, do not shift the transmis-

sion directly from **D** to **R**, from **R** to **D** or directly to **P**.

Do not open the driver's door while the vehicle is in motion. At low speeds in transmission position **D** or **R**, park position **P** is otherwise engaged automatically.

The transmission could be damaged.

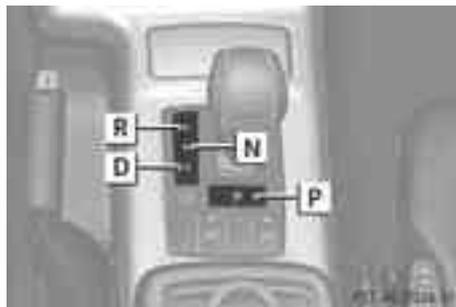

Selector lever

- P** Park position
- R** Reverse gear
- N** Neutral
- D** Drive

When you select a transmission position, the selector lever subsequently returns to its original position.

The current transmission position **P**, **R**, **N** or **D** appears in the transmission position display in the multifunction display.

### Transmission position and drive program display



① Transmission position

② Drive program

Current transmission position ① and current drive program ② appear in the multifunction display.

When the selector lever is in position **D**, you can influence the gearshifts made by the automatic transmission by:

- restricting the shift range
- changing gear yourself

### Engaging park position P

- ▶ When the vehicle is stationary, depress the brake pedal and keep it depressed.
- ▶ Press the **P** button in the centre console.

**i** If you depress the brake pedal and push the selector lever forwards or back to the first point of resistance, park position **P** is disengaged. The transmission shifts to neutral **N**.

Park position **P** is automatically engaged:

- if you remove the key from the ignition lock
- if you open the driver's door while travelling at low speed in transmission position **D** or **R**
- if DISTRONIC PLUS (> page 182) brakes your vehicle until it is stationary and at least one of the following conditions is fulfilled:
  - the engine is switched off.
  - the driver's door is open and the seat belt is not fastened.
  - there is a system malfunction.
  - the power supply is insufficient.

### Engaging reverse gear R

**i** Only shift the automatic transmission to **R** when the vehicle is stationary.

- ▶ When the vehicle is stationary, depress the brake pedal and keep it depressed.
- ▶ Push the selector lever forwards past the first point of resistance. Transmission position **R** is engaged.

**i** **For AMG vehicles:** when reverse gear is engaged and the ECO start/stop function is switched on, the engine starts up automatically (> page 145).

### Shifting to neutral (N)

If the vehicle is stationary:

- ▶ Depress the brake pedal.
- ▶ Depending on the current transmission position, press the selector lever forwards or backwards to the first point of resistance.

The automatic transmission shifts to **N**.

When the engine is switched off, the automatic transmission shifts to **N** automatically.

**i** **For AMG vehicles:** the ECO start/stop function switches the engine off automatically if the vehicle is braked to a standstill when in neutral **N** and the brake is still depressed (> page 145).

## Staying in neutral (N)

### WARNING

If children are left unsupervised in the vehicle, they could:

- open the doors, thus endangering other people or road users.
- get out and disrupt traffic.
- operate the vehicle's equipment.

Additionally, children could set the vehicle in motion if, for example, they:

- release the parking brake.
- shift the automatic transmission out of parking position P.
- start the engine.

There is a risk of an accident and injury.

When leaving the vehicle, always take the key with you and lock the vehicle. Never leave children or animals unattended in the vehicle. Always keep the key out of reach of children.

- ▶ Make sure the ignition is switched on.
- ▶ When the vehicle is stationary, depress the brake pedal and keep it depressed.
- ▶ Select neutral **N**.
- ▶ Release the brake pedal.
- ▶ If the parking brake is applied, release it.
- ▶ Switch off the ignition and leave the key in the ignition lock.

## Shifting to transmission position D

- ▶ When the vehicle is stationary, depress the brake pedal and keep it depressed.
- ▶ Push the selector lever back past the first point of resistance.  
Transmission position **D** is engaged.

**i** For AMG vehicles: the ECO start/stop function switches the engine off automatically if the vehicle is braked to a standstill when in transmission position **D** and the brake is still depressed (▷ page 145).

## Transmission positions

### **P** Park position

This prevents the vehicle from rolling away when stopped. Do not shift the transmission into position **P** (▷ page 149) unless the vehicle is stationary.

**i** The key can only be removed if the transmission is in position **P**. When there is no key in the ignition lock, the selector lever is locked in position **P**.

Have the vehicle electronics checked immediately at a qualified specialist workshop.

### **R** Reverse gear

Only shift the transmission to **R** when the vehicle is stationary.

### **N** Neutral

No power is transmitted from the engine to the drive wheels.

Releasing the brakes will allow you to move the vehicle freely, e.g. to push it or tow it.

Do not shift the transmission to **N** while driving. Otherwise, the automatic transmission could be damaged.

If ESP® is deactivated or faulty: only shift the transmission to position **N** if the vehicle is in danger of skidding, e.g. on icy roads.

If you want to engage the transfer case, shift briefly into **N** (▷ page 202).

**!** Rolling in neutral **N** can lead to damage to the transmission.

### **D** Drive

The automatic transmission changes gear automatically. All forward gears are available.

### Changing gear

The automatic transmission shifts to the individual gears automatically when it is in transmission position **D**. Gearshifting is determined by:

- a shift range restriction, if selected
- the position of the transfer case (**HIGH RANGE** or **LOW RANGE**)
- the position of the accelerator pedal
- the road speed

### Driving tips

#### Accelerator pedal position

Your style of driving influences how the automatic transmission shifts gear:

- little throttle: early upshifts
- more throttle: late upshifts

#### Kickdown

Use kickdown for maximum acceleration.

- ▶ Depress the accelerator pedal beyond the pressure point.  
The transmission shifts to a lower gear depending on the engine speed.
- ▶ Ease off the accelerator pedal once the desired speed is reached.  
The automatic transmission shifts back up.

#### Towing a trailer

- ▶ Drive in the middle of the engine speed range on uphill gradients.
- ▶ Limit shift range to **3** or **2** depending on the uphill or downhill gradient (> page 153), even if cruise control or SPEEDTRONIC is activated.
- ▶ Shift the transfer case into low-range driving position **LOW RANGE** on extreme uphill gradients or steep downhill gradients (> page 202).

### Program selector button

#### General notes

The program selector button allows you to choose between drive programs with different driving characteristics.

- ① On AMG vehicles, drive program **E** is called drive program **C**.

#### Driving programs

<b>E</b> Economy <b>C</b> Controlled Efficiency	Comfortable, economical driving
<b>S</b> Sport	Sporty driving style
<b>M</b> Manual	Manual gearshifting

- ① The automatic transmission switches to automatic drive program **E** (drive program **C** in AMG vehicles) each time the engine is started.
- ① For further information on the automatic drive program, see (> page 153).

#### Selecting the drive program

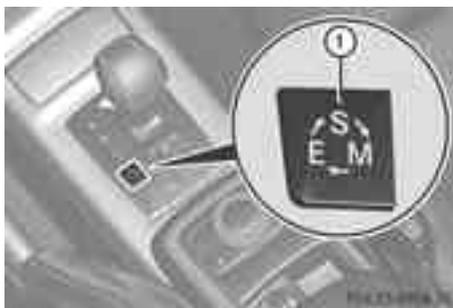

Example: program selector button

- ▶ Press program selector button ① repeatedly until the letter for the desired gearshift program appears in the multifunction display.

### Steering wheel gearshift paddles



In the automatic drive program, you can restrict or derestrict the shift range by using steering wheel gearshift paddles ① and ② (▷ page 153).

In the manual drive program you can change gears manually using steering wheel gearshift paddles ① and ② (▷ page 154).

- ❗ You can only change gear with the steering wheel gearshift paddles when the transmission is in position **D**.

### Automatic drive program

Drive program **E** (drive program **C** on AMG vehicles) is characterised by the following:

- comfort-oriented engine and transmission settings
- optimal fuel consumption resulting from the automatic transmission shifting up sooner
- the vehicle pulling away more gently in forward and reverse gears, unless the accelerator pedal is depressed fully
- increased sensitivity. This improves driving stability on slippery road surfaces, for example
- the automatic transmission shifting up sooner. This results in the vehicle being driven at lower engine speeds and the wheels being less likely to spin

Drive program **S** is characterised by the following:

- sporty engine and transmission settings
- the vehicle pulling away in first gear
- the automatic transmission shifting up later
- as a result of the later automatic transmission shift points, the fuel consumption possibly being higher

### Shift ranges

#### Introduction

When the automatic transmission is in position **D**, it is possible to restrict or derestrict the shift range.

The shift range selected is shown in the multifunction display. The automatic transmission shifts only as far as the selected gear.

#### Driving situations

<b>3</b>	To use the engine's braking effect
<b>2</b>	The braking effect of the engine can be utilised on downhill gradients or when driving: <ul style="list-style-type: none"> <li>• on steep mountain roads</li> <li>• in mountainous terrain</li> <li>• in arduous conditions</li> </ul>
<b>1</b>	The braking effect of the engine can be utilised on extremely steep downhill gradients and long downhill stretches.

#### Restricting the shift range

- ▶ Pull the left-hand steering wheel gearshift paddle (▷ page 153).  
The automatic transmission shifts down one gear and restricts the shift range to the relevant gear.

- ❗ If the engine exceeds the maximum engine speed when shifting down, the auto-

matic transmission protects against engine damage by not shifting down.

- i** If the maximum engine speed for the shift range is reached and you continue to accelerate, the automatic transmission shifts up in order to prevent the engine from over-revving, even if the shift range is restricted.

### Extending the shift range

- ▶ Pull the right-hand steering wheel gearshift paddle (▷ page 153).  
The automatic transmission shifts up one gear and restricts the shift range to the relevant gear.

### Clearing the shift range restriction

- ▶ Pull and hold the right-hand steering wheel gearshift paddle (▷ page 153) until **D** is shown again in the multifunction display. The automatic transmission shifts from the current shift range directly to **D**.

### Selecting the ideal shift range

- ▶ Pull the left-hand steering wheel gearshift paddle (▷ page 153) and hold it in position. The automatic transmission shifts to the gear which allows optimum acceleration and deceleration. To do this, the automatic transmission shifts down one or more gears.
- i** The automatic transmission cannot shift down beyond second gear. To shift to first gear, you have to pull the left steering wheel gearshift paddle.

## Manual drive program

### Introduction

In drive program **M**, you can change gear manually using the steering wheel gearshift paddles. For this, the transmission must be in position **D**. The gear currently selected and

engaged is shown in the multifunction display.

Manual drive program **M** differs from drive programs **E** and **S** with regard to spontaneity, responsiveness and smoothness of gear changes.

### Activating the manual drive program

- ▶ Press the program selector button (▷ page 152) repeatedly until **M** appears in the multifunction display.

### Upshifting (except AMG vehicles)

- ▶ Pull the right-hand paddle (▷ page 153).  
The automatic transmission shifts up to the next gear.

### Upshifting (AMG vehicles)

- !** In manual gearshift program **M**, the automatic transmission does not shift up automatically even when the engine limiting speed for the current gear is reached. When the engine limiting speed is reached, the fuel supply is cut to prevent the engine from overrevving. You must make sure that the engine speed does not reach the red area of the rev counter. Otherwise, there is a risk of engine damage.
- ▶ Pull the right-hand paddle (▷ page 153).  
The automatic transmission shifts up to the next gear.

Before the engine speed reaches the red area, an upshift indicator will be shown in the multifunction display.

- ▶ If the colour in the speedometer multifunction display changes to red and the **UP** display message is shown, shift up a gear.

### Downshifting

- ▶ Pull the left-hand paddle (▷ page 153).  
The automatic transmission shifts down to the next gear.

- i** If you slow down or stop without shifting down, the automatic transmission automatically shifts down.

### Selecting the optimal gear for maximum acceleration

---

- ▶ Pull the left-hand steering wheel gearshift paddle until the transmission selects the optimum gear for the current speed.

### Kickdown

---

You can also use kickdown for maximum acceleration in manual drive program **M**.

- ▶ Depress the accelerator pedal beyond the pressure point.  
The transmission shifts to a lower gear depending on the engine speed.
- ▶ Shift back up once the desired speed is reached.

- i** **Vehicles with an AMG engine:** it is not possible to use kickdown in manual drive program **M**.

- i** **Vehicles without an AMG engine:** if you apply full throttle, the automatic transmission shifts up to the next gear when the maximum engine speed is reached. This prevents the engine from overrevving.

### Deactivating the manual drive program

---

- ▶ Press the program selector button (▷ page 152) repeatedly until **E** (**C** in AMG vehicles) or **S** appears in the multifunction display.

Problems with the automatic transmission	
Problem	Possible causes/consequences and ► Solutions
The transmission has problems shifting gear.	The transmission is losing oil. ► Have the transmission checked at a qualified specialist workshop immediately.
The acceleration ability is deteriorating. The transmission no longer changes gear.	The transmission is in emergency mode. It is only possible to shift into <b>second</b> gear and reverse gear. ► Stop. ► Shift the transmission to position <b>P</b> . ► Turn the key to position <b>0</b> in the ignition lock. ► Wait at least ten seconds before restarting the engine. ► Shift the transmission to position <b>D</b> or <b>R</b> . If <b>D</b> is selected, the transmission shifts into <b>second</b> gear; if <b>R</b> is selected, the transmission shifts into reverse gear. ► Have the transmission checked at a qualified specialist workshop immediately.
You hear a warning tone.	You have: <ul style="list-style-type: none"> <li>• switched off the engine</li> <li>• opened the driver's door</li> <li>• not moved the selector lever to position <b>P</b></li> </ul> ► Move the selector lever to <b>P</b> .

## Refuelling

### Important safety notes

#### WARNING

Fuel is highly flammable. If you handle fuel incorrectly, there is a risk of fire and explosion.

You must avoid fire, naked flames, creating sparks and smoking. Switch off the engine and, if applicable, the auxiliary heating before refuelling.

#### WARNING

Fuels are poisonous and hazardous to health. There is a danger of injury.

Do not swallow fuel or let it come into contact with skin, eyes or clothing. Do not inhale fuel

vapours. Keep fuels out of the reach of children.

If you or others come into contact with fuel, observe the following:

- Wash the fuel off any affected areas of skin with water and soap immediately.
- If you get fuel in your eyes, rinse them thoroughly with clean water immediately. Seek immediate medical attention.
- If fuel is swallowed, seek immediate medical attention. Do not induce vomiting.
- Change any clothing that has come into contact with fuel immediately.

#### WARNING

Do not use petrol to refuel vehicles with a diesel engine. Do not mix diesel with petrol. This

would result in damage to the fuel system and engine, which could lead to a vehicle fire.

- !** Do not use petrol to refuel vehicles with a diesel engine. Do not use diesel to refuel vehicles with a petrol engine. Even small amounts of the wrong fuel result in damage to the fuel system and the engine.
- !** Do not switch on the ignition if you accidentally refuel with the wrong fuel. Otherwise, the fuel will enter the fuel lines. Notify a qualified specialist workshop and have the fuel tank and fuel lines drained completely.
- !** Overfilling the fuel tank could damage the fuel system.
- !** Take care not to spill any fuel on painted surfaces. You could otherwise damage the paintwork.
- !** Use a filter when adding fuel from a fuel can. The fuel lines and/or the diesel injection system could otherwise be blocked by particles from the fuel can.

For further information on fuel and fuel quality (▷ page 337).

## Refuelling

### Fuel filler flap

- !** AdBlue® is not a fuel additive and must not be added to the fuel tank. If AdBlue® is added to the fuel tank, this can lead to engine damage.

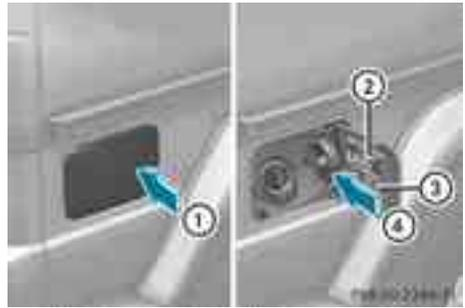

Example: fuel filler cap G 500

- ① To open the fuel filler flap
- ② Tyre pressure table
- ③ Fuel type
- ④ To insert the fuel filler cap

When you open or close the vehicle with the key, the fuel filler flap is automatically unlocked or locked.

The position of the fuel filler cap is displayed  in the instrument cluster. The arrow next to the filling pump indicates the side of the vehicle. The fuel filler flap is located to the rear on the right.

### Opening

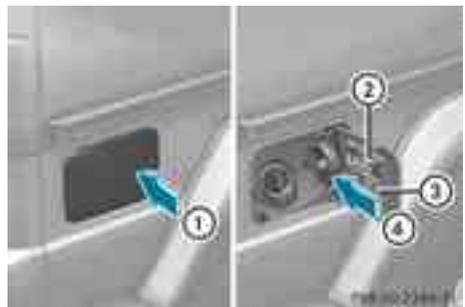

- ① To open the fuel filler flap
- ② Tyre pressure table
- ③ Fuel type
- ④ To insert the fuel filler cap

- ▶ Press the fuel filler flap in the direction of arrow ①.  
The fuel filler flap opens slightly.
- ▶ Open the fuel filler flap.

- ▶ Turn the fuel filler cap anti-clockwise and remove it.

**AdBlue® vehicles:** do not confuse the fuel filler cap with the blue AdBlue® filler cap.

- ▶ Insert the fuel filler cap into the holder bracket on the inside of filler flap ④.
- ❗ AdBlue® vehicles do not have a bracket on the inside of the filler flap.
- ▶ Completely insert the filler neck of the fuel pump nozzle into the tank and refuel.
- ❗ Do not add any more fuel after the pump stops filling for the first time. Otherwise, fuel may leak out.

### Closing

- ▶ Replace the fuel filler cap and turn it clockwise. The fuel filler cap audibly engages.
- ▶ Press the fuel filler flap closed until it engages.

### Fuel filler flap emergency release

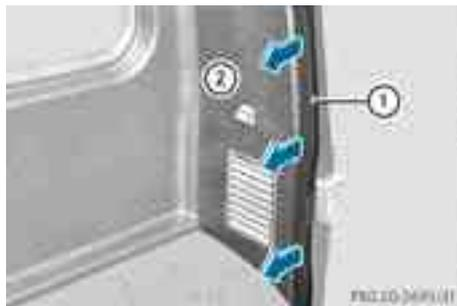

**G-Class long-wheelbase version:** the emergency release is located in the luggage compartment on the right-hand side, when viewed in the direction of travel, behind the rear panel trim.

- ❗ The vehicle body in the emergency release area has sharp edges. There is a risk of injury. Avoid contact with the edges on the inside of the vehicle body.

- ▶ Open the rear door.
- ▶ Remove edge protection ①.
- ▶ Remove rear panel trim ②.



- ▶ Pull emergency release ③ in the direction of the arrow. The fuel filler flap is released.
- ▶ Open the fuel filler flap.

**G-Class Cabriolet:** the emergency release is located in the luggage compartment on the right-hand side, when viewed in the direction of travel.

- ▶ Open the tailgate.



- ❗ The vehicle body in the emergency release area has sharp edges. There is a risk of injury. Avoid contact with the edges on the inside of the vehicle body.
- ▶ Pull emergency release ① upwards. The fuel filler flap is released.
- ▶ Open the fuel filler flap.

Problems with the fuel and fuel tank	
Problem	Possible causes/consequences and ► Solutions
Fuel is leaking from the vehicle.	<p> <b>Risk of explosion or fire</b></p> <p>The fuel line or the fuel tank is defective.</p> <ul style="list-style-type: none"> <li>► Turn the key to position <b>0</b>(▷ page 143) in the ignition lock immediately and remove it.</li> <li>► Do not restart the engine under any circumstances.</li> <li>► Consult a qualified specialist workshop.</li> </ul>
The fuel filler flap cannot be opened.	<p>The fuel filler flap is not unlocked.</p> <p>or</p> <p>The key batteries are discharged.</p> <ul style="list-style-type: none"> <li>► Unlock the vehicle (▷ page 68).</li> </ul> <p>or</p> <ul style="list-style-type: none"> <li>► Unlock the vehicle using the emergency key element (▷ page 70).</li> <li>► Open the rear door.</li> <li>► Manually unlock the fuel filler flap using the emergency release (▷ page 158).</li> </ul> <p>The fuel filler flap is unlocked, but the opening mechanism is jammed.</p> <ul style="list-style-type: none"> <li>► Manually unlock the fuel filler flap using the emergency release (▷ page 158).</li> <li>► Consult a qualified specialist workshop.</li> </ul>
The engine does not start.	<p>The fuel tank of a vehicle with a diesel engine has been run completely dry.</p> <ul style="list-style-type: none"> <li>► Refuel the vehicle with at least 5 litres of diesel.</li> <li>► Turn the ignition on for around 10 seconds(▷ page 143).</li> <li>► Start the engine continuously for up to 40 seconds until it runs smoothly.</li> </ul> <p>If the engine does not start:</p> <ul style="list-style-type: none"> <li>► Turn the ignition on again for approximately 10 seconds(▷ page 143).</li> <li>► Start the engine again continuously for up to 40 seconds until it runs smoothly.</li> </ul> <p>If the engine does not start after three attempts:</p> <ul style="list-style-type: none"> <li>► Consult a qualified specialist workshop.</li> </ul>

**AdBlue®****Important notes on use**

To function properly, BlueTEC exhaust gas aftertreatment<sup>1</sup> must be operated with the reducing agent AdBlue®.

When the supply of AdBlue® is almost used up, the [Refill AdBlue See Owner's Manual](#) message is shown in the multifunction display. A warning tone also sounds.

If the [Refill AdBlue No start in: .. km](#) message is shown in the multifunction display, you can still drive the vehicle over the distance shown. A warning tone also sounds. If the AdBlue® is not topped up, you will subsequently be unable to start the engine.

After receiving the warning message, it is preferable to fill the AdBlue® tank with 10 litres of AdBlue®. In this way, you can ensure that the AdBlue® supply lasts until the next regular service date.

Further information about BlueTEC exhaust gas aftertreatment and about AdBlue® can be obtained from any Mercedes-Benz Service Centre.

**Topping up AdBlue®**

**!** Only use AdBlue® in accordance with ISO 22241. Do not mix any additives with AdBlue®, and do not dilute AdBlue® with water. This may destroy the BlueTEC exhaust gas aftertreatment system.

**!** In order to fill the AdBlue® tank, the vehicle must be parked on a level surface. The AdBlue® tank can only be filled as intended with the vehicle parked on a level surface. Fluctuations in capacity will thus be avoided. Filling a vehicle standing on an uneven surface is not permitted. There is a danger of overfilling, which can cause damage to BlueTEC exhaust gas aftertreatment components.

**!** Do not fill the AdBlue® container with a pump nozzle.

**!** If there are steep gradients while driving off-road, a sufficient filling level in the AdBlue® tank must be ensured. Make sure for this reason that there is a minimum fill level of ten litres before driving off-road.

**!** Surfaces which have come into contact with AdBlue® while refilling should be rinsed immediately with water, or remove AdBlue® with a moist cloth and cold water. If AdBlue® has already crystallised, use a sponge and cold water to clean the area. AdBlue® residue crystallises after a certain amount of time and soils the affected surfaces.

**!** AdBlue® is not a fuel additive and must not be added to the fuel tank. If AdBlue® is added to the fuel tank, this can lead to engine damage.

If you open the AdBlue® tank cap, small amounts of ammonia vapour may be released.

Ammonia vapours have a pungent odour and are particularly irritating to:

- skin
- mucous membranes
- eyes

You may experience a burning sensation in your eyes, nose and throat, as well as coughing and watering of the eyes.

Do not inhale any ammonia vapours that may be released. Fill the AdBlue® tank only in well-ventilated areas.

<sup>1</sup> BlueTEC vehicles only.

AdBlue® must not come into contact with your skin, eyes or clothing.

- If you get AdBlue® in your eyes or on your skin, rinse thoroughly without delay using clear water.
- If AdBlue® has been swallowed, rinse your mouth out immediately with plenty of clean water, and drink plenty of water.
- Change immediately out of clothing contaminated with AdBlue®.
- If you notice allergic reactions, visit a doctor immediately.

Keep AdBlue® away from children.

Have the AdBlue® tank refilled at a qualified specialist workshop. However, you can also top up the AdBlue® tank:

- with AdBlue® refill bottles
- with an AdBlue® refill canister

If the outside temperature is below -11 °C, it may be difficult to top up. If AdBlue® is frozen and there is an active warning indicator, topping up may not be possible. Park the vehicle in a warm place, e.g. in a garage, until AdBlue® has become liquid again. Topping up is then possible again. Alternatively, have the AdBlue® tank refilled at a qualified specialist workshop.

Have the AdBlue® supply checked at a qualified specialist workshop before the following types of journeys:

- journeys abroad outside of Europe
  - off-road driving
- If necessary, have AdBlue® topped up.

Before a longer stay outside of Europe, consult a qualified specialist workshop.

For further information on AdBlue®, see (► page 341).

## Opening the AdBlue® filler cap



The filler neck for AdBlue® is located behind the fuel filler flap on the rear right-hand side.

- Switch the ignition off.
- Press the fuel filler flap in the direction of arrow ①.

The fuel filler flap swings up.

- Turn blue AdBlue® filler cap ② anti-clockwise and remove it.

AdBlue® filler cap ② is secured with a plastic strip.

## AdBlue® refill canisters

- ❗ Do not tighten disposable hose ② with too much force. Disposable hose ② may otherwise be destroyed.

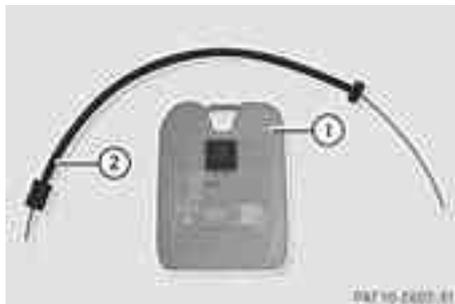

AdBlue® refill canisters can be obtained at many filling stations or at a Mercedes-Benz Service Centre. AdBlue® refill canisters are often sold with a filler hose. A filler hose that does not exactly fit the vehicle's AdBlue® tank offers no protection against overfilling.

AdBlue® may leak out as a result of overfilling. Mercedes-Benz offers a special disposable hose with overflow protection. You can obtain this from any Mercedes-Benz Service Centre. AdBlue® is available in a variety of containers and receptacles. Only use the disposable hose with Mercedes-Benz AdBlue® refill canisters.



- ▶ Unscrew the cap from the opening on top of AdBlue® refill canister ①.
- ▶ Place disposable hose ② on the opening of AdBlue® refill canister ① and screw it on clockwise until hand-tight.
- ❗ Disposable hose ② remains closed until you fasten disposable hose ② to the AdBlue® filler neck of the vehicle.
- ▶ Place disposable hose ② on the filler neck of the vehicle and screw it on clockwise until hand-tight. When you feel resistance, disposable hose ② is sufficiently secured.
- ▶ Lift up and tip AdBlue® refill canister ①.
- ❗ Filling stops when the AdBlue® tank is completely filled. Do not fill the AdBlue® tank any further. AdBlue® refill canister ① can be removed when it has been only partially emptied.
- ▶ Turn disposable hose ② on the filler neck of the vehicle anti-clockwise and remove it.

- ▶ Turn disposable hose ② on the opening of AdBlue® refill canister ① anti-clockwise and remove it.
- ▶ Reseal AdBlue® refill canister ① with the cap.

### AdBlue® refill bottle

- ❗ Screw on the AdBlue® refill bottle only hand-tight. It may otherwise be destroyed.



AdBlue® refill bottles can be obtained at many filling stations or at a Mercedes-Benz Service Centre. Refill bottles without a threaded seal offer no protection against overfilling. AdBlue® may leak out as a result of overfilling. Mercedes Benz offers special refill bottles with a threaded cap. These are available at any Mercedes-Benz Service Centre.

- ▶ Unscrew the protective cap from AdBlue® refill bottle ①.
- ▶ Set AdBlue® refill bottle ① as shown on the filler neck and screw it on hand-tight.
- ▶ Press AdBlue® refill bottle ① towards the filler neck.  
The AdBlue® tank is filled. This could last up to one minute.
- ❗ When the AdBlue® refill bottle is no longer pressed down, filling stops. The bottle may be taken off again after being only partially emptied.
- ▶ Release AdBlue® refill bottle ①.

- ▶ Turn AdBlue® refill bottle ① anti-clockwise and remove it.
- ▶ Screw the protective cap onto AdBlue® refill bottle ① again.

### Closing the AdBlue® filler cap and fuel filler flap

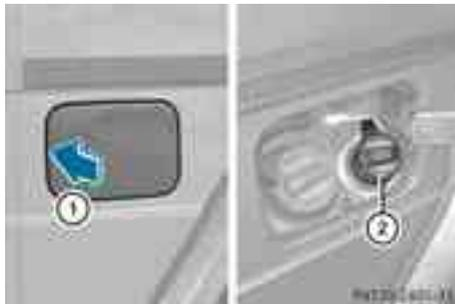

- ▶ Fit blue AdBlue® filler cap ② on the filler neck and turn it clockwise.
- ▶ To close the fuel filler flap, press it in the direction of arrow ①.

**i** The [Refill AdBlue See Owner's Manual](#) message goes out at the latest after a driving distance of several kilometres.

**i** Have the AdBlue® supply topped up fully if necessary. Mercedes-Benz recommends that you use a qualified specialist workshop for this purpose.

## Parking

### Important safety notes

#### **⚠ WARNING**

If you leave children unsupervised in the vehicle, they could set it in motion by, for example:

- releasing the parking brake
- shifting the automatic transmission out of the parking position **P**
- starting the engine.

They could also operate the vehicle's equipment. There is a risk of an accident and injury.

When leaving the vehicle, always take the key with you and lock the vehicle. Never leave children unsupervised in the vehicle.

#### **⚠ WARNING**

If flammable materials such as leaves, grass or twigs are exposed to prolonged contact to parts of the exhaust system that heat up, they could ignite. There is a risk of fire.

Park the vehicle so that no flammable materials come into contact with parts of the vehicle which are hot. Take particular care not to park on dry grassland or harvested grain fields.

#### **⚠ WARNING**

If you switch off the ignition while driving, safety-relevant functions are only available with limitations, or not at all. This could affect, for example, the power steering and the brake boosting effect. You will require considerably more effort to steer and brake. There is a risk of an accident.

Do not switch off the ignition while driving.

To ensure that the vehicle is secured against rolling away unintentionally:

- the parking brake must be applied.
- the transmission must be in position **P** and the key must be removed from the ignition lock
- the transfer case must not be in position **N**.
- on uphill or downhill gradients, turn the front wheels towards the kerb.

### Switching off the engine

### Important safety notes

#### **⚠ WARNING**

If you switch off the ignition while driving, safety-relevant functions are only available with limitations, or not at all. This could affect, for example, the power steering and the brake

boosting effect. You will require considerably more effort to steer and brake. There is a risk of an accident.

Do not switch off the ignition while driving.

### Vehicles with automatic transmission

- ▶ Shift the transmission to position **P**.
  - ▶ Turn the key to position **0** in the ignition lock (> page 143) and remove it. The immobiliser is activated.
  - ▶ Apply the parking brake firmly.
  - ▶ Turn the steering wheel until the steering wheel lock engages.
- i** If you switch the engine off with the transmission in position **R** or **D**, the automatic transmission shifts to **N** automatically. If you then open one of the front doors or remove the key from the ignition, the automatic transmission shifts to **P**. If you shift the automatic transmission to **N** before switching off the engine, the automatic transmission remains in **N** even if a door is opened.
- i** The key can only be removed if the automatic transmission is in position **P**.

### Parking brake



- i** When you apply parking brake ② to brake the vehicle, the brake lamps do not light up.
- ▶ **To apply:** pull parking brake ② up firmly. Parking brake ② is applied.

If the key is in position **1** or **2** in the ignition lock, the  indicator lamp in the instrument cluster is lit.

- ▶ **To release:** depress the brake pedal and keep it depressed. The selector lever lock is released.
  - ▶ Pull parking brake ② up firmly.
  - ▶ Press release button ① on parking brake ② and move parking brake ② down to the stop. The  indicator lamp in the instrument cluster goes out.
- i** If you pull away with parking brake ② applied, a warning tone sounds.

### Parking up the vehicle

If you leave the vehicle parked up for longer than four weeks, the battery may be damaged by exhaustive discharging.

- ▶ Disconnect the battery.
- or
- ▶ Connect the battery to a trickle charger.
- i** You can obtain information about trickle chargers from a qualified specialist workshop.

If you leave the vehicle parked up for longer than six weeks, the vehicle may suffer damage as a result of lack of use.

- ▶ Visit a qualified specialist workshop and seek advice.

### Driving tips

#### Short journeys

- !** **Vehicles with a diesel particle filter:** if the vehicle is mostly driven for short distances, it is possible that malfunctions may occur during the automatic cleaning of the diesel particle filter. This may lead to fuel collecting in the engine oil and cause engine failure. Therefore, if you frequently

drive short distances, you should take a 20 minute trip on a motorway or rural road at least every 500km.

## Brakes

### Important safety notes

#### WARNING

If you shift down on a slippery road surface in an attempt to increase the engine's braking effect, the drive wheels could lose their grip. This increases the risk of skidding and having an accident.

Do not shift down for additional engine braking on a slippery road surface.

### Downhill gradients

On long and steep downhill gradients, especially if the vehicle is laden or towing a trailer, you must select shift range **1, 2 or 3** (▷ page 153) in good time.

 This also applies if you have activated cruise control or SPEEDTRONIC.

This will use the braking effect of the engine, so less braking will be required to prevent the vehicle from gaining speed. This relieves the load on the brake system and prevents the brakes from overheating and wearing too quickly. If you need additional braking, depress the brake pedal repeatedly rather than continuously.

### Heavy and light loads

#### WARNING

The braking system can overheat if you leave your foot on the brake pedal while driving. This increases the braking distance and could even cause the braking system to fail. There is a risk of an accident.

Never use the brake pedal as a footrest. Do not simultaneously depress both the brake pedal and the accelerator pedal while driving.

If the brakes have been subjected to a heavy load, do not stop the vehicle immediately, but drive on for a short while. This allows the airflow to cool the brakes more quickly.

If the brakes have been used only moderately, you should occasionally test their effectiveness. To do this, brake more firmly from a higher speed. This improves the grip of the brakes.

### Wet road surfaces

If driving in heavy rain for a prolonged period of time without braking, there may be a delayed reaction from the brakes when braking for the first time. This may also occur after the vehicle has been washed.

You have to depress the brake pedal more firmly. Maintain a greater distance from the vehicle in front.

After driving on a wet road or having the vehicle washed, brake firmly while paying attention to the traffic conditions. This will warm up the brake discs, thereby drying them more quickly and protecting them against corrosion.

### Limited braking performance on salt-treated roads

If you drive on salt-treated roads, a layer of salt may form on the brake discs and pads. This can increase the braking distance considerably.

- Apply the brakes occasionally in order to prevent any salt build-up. Ensure that you do not endanger other road users when doing so.
- Carefully depress the brake pedal at the end of the journey and when starting the next journey.
- Maintain a much greater distance to the vehicle in front.

## New brake pads/linings

New brake pads/brake pads and discs that have been replaced only achieve optimum braking effect after several hundred kilometres of driving. Compensate for the reduced braking effect by applying greater force to the brake pedal.

For safety reasons, Mercedes-Benz recommends that you only have brake pads/linings fitted to your vehicle which have been approved for Mercedes-Benz vehicles or which correspond to an equivalent quality standard. Brake pads/linings which have not been approved for Mercedes-Benz vehicles or which are not of an equivalent quality could affect your vehicle's operating safety.

## High-performance brake system for AMG vehicles

The high-performance brake system is designed for high loads. This may lead to noise when braking. This is dependent on:

- speed
- braking force
- environmental conditions, such as temperature and humidity.

The wear of individual components of the brake system, such as the brake pads/linings or brake discs, depends on the individual driving style and operating conditions.

For this reason, it is impossible to state a mileage (service life) that will be valid under all circumstances. An aggressive driving style will lead to high wear. You can obtain further information about this from your Mercedes-Benz Service Centre.

## Parking brake

### WARNING

If you must brake the vehicle with the parking brake, the braking distance is considerably longer and the wheels could lock. This increases the risk of skidding and an accident.

Only use the parking brake to brake the vehicle when the service brake is faulty. Do not apply the parking brake too firmly. If the wheels lock, release the parking brake until the wheels begin turning again.

When you apply the parking brake to brake the vehicle, the brake lamps do not light up. If you drive on wet roads or dirt-covered surfaces, road salt and/or dirt could get into the parking brake.

In order to prevent corrosion and a reduction in the braking power of the parking brake, observe the following:

- pull the parking brake upwards with the release button depressed from time to time before beginning the journey (▷ page 164).
- drive for approximately 100 m at a maximum speed of 20 km/h.

## Tyre traction

### WARNING

Whereas the vehicle can be fully controlled at a certain speed on dry roads, you must reduce your speed on wet or icy roads to achieve the same road safety. You could otherwise cause an accident.

Pay particular attention to the road conditions at temperatures around freezing point.

If ice has formed on the road surface (e.g. from fog), a thin film of water rapidly forms on the ice when you brake, considerably reducing tyre traction. Drive with particular care in such weather conditions.

## Driving on slippery surfaces

- ❗ If possible, do not let the drive wheels spin. Otherwise, you could damage the drive train.
- ▶ Engage the differential locks if necessary (▷ page 204).

## Driving on wet roads

### Aquaplaning

If water has accumulated to a certain depth on the road surface, there is a danger of aquaplaning occurring, even if:

- you are driving at low speeds
- the tyres have adequate tread depth.

For this reason, do not drive in tyre ruts, and brake carefully.

### Driving on flooded roads

**!** Bear in mind that vehicles travelling in front or in the opposite direction create waves. This may cause the maximum permissible water depth to be exceeded.

These notes must be observed under all circumstances. You could otherwise damage the engine, the electronics or the transmission.

If you have to drive on stretches of road on which water has collected, please bear in mind that:

- the maximum permissible fording depth in still water is 60 cm
- you should drive no faster than walking pace

### Off-road fording

**!** The water depth must not exceed 60 cm. Note that the possible fording depth is less in flowing water.

**!** Under no circumstances should you accelerate before entering the water. The bow wave could cause water to enter and damage the engine and neighbouring assemblies.

**!** Do not open any of the vehicle's doors while fording. Otherwise, water could get into the vehicle interior and damage the vehicle's electronics and interior equipment.



The fording depth must not exceed 60 cm when the vehicle is loaded and ready to drive. Loaded and ready to drive means: a full tank, all fluids topped up and the driver is in the vehicle.

**i** You may only drive through freshwater.

- Observe the safety notes (▷ page 169) and the general notes (▷ page 169) on off-road driving.
- Establish how deep the water is and the characteristics of the body of water before fording.
- Switch off the air-conditioning system.
- Deactivate the auxiliary heating.
- Shift the transfer case to **LOW RANGE**(▷ page 201).
- Engage the differential locks, if necessary (▷ page 204).
- Restrict the shift range to **1** or **2**(▷ page 153).
- Avoid high engine speeds.
- Enter and exit the water at a flat place and at a steady walking pace.
- Drive slowly and at a constant speed through the water.
- Do not stop and do not switch off the engine.
- Water offers a high degree of resistance, the ground is slippery and, in some cases, unstable. Therefore, it is difficult and dangerous to pull away in the water.
- Ensure that a bow wave does not form as you drive.

- Clean any mud from the tyre tread after fording.
- Apply the brakes to dry them after fording.
- Water offers a high degree of resistance, the ground is slippery and, in some cases, unstable. Therefore, it is difficult and dangerous to pull away in the water.
- Ensure that a bow wave does not form as you drive.
- Clean any mud from the tyre tread after fording.
- Apply the brakes to dry them after fording.

### Parking the vehicle after heavy loads on the engine

**!** **Vehicles with a diesel engine:** your vehicle's exhaust gas turbocharger may get very hot under heavy engine load, e.g. during:

- trailer towing
  - longer motorway journeys at high speed
  - longer journeys through mountainous terrain
- Let the engine run for approximately another two minutes while the vehicle is stationary before switching off the engine. This way, the exhaust gas turbocharger can cool down more effectively.

### Winter driving

#### General notes

#### DANGER

If the exhaust pipe is blocked or adequate ventilation is not possible, poisonous gases such as carbon monoxide (CO) may enter the vehicle. This is the case, e.g. if the vehicle becomes trapped in snow. There is a risk of fatal injury.

If you leave the engine or the auxiliary heating running, make sure the exhaust pipe and area around the vehicle are clear of snow. To

ensure an adequate supply of fresh air, open a window on the side of the vehicle that is not facing into the wind.

#### WARNING

If you have fitted snow chains to the front wheels, they may scrape against the vehicle body or chassis components. This could cause damage to the vehicle or the tyres.

There is a risk of an accident.

To avoid hazardous situations:

- never fit snow chains on the front wheels
- fit snow chains to the rear wheels in pairs.

At the onset of winter, have your vehicle winterproofed at a qualified specialist workshop. Observe the notes in the "Winter operation" section (▷ page 319).

### Driving with summer tyres

Observe the notes in the "Winter operation" section (▷ page 319).

### Slippery road surfaces

#### WARNING

If you shift down on a slippery road surface in an attempt to increase the engine's braking effect, the drive wheels could lose their grip. This increases the risk of skidding and having an accident.

Do not shift down for additional engine braking on a slippery road surface.

You should drive particularly carefully on slippery road surfaces. Avoid sudden acceleration, steering and braking manoeuvres.

If the vehicle threatens to skid or cannot be stopped when moving at low speed:

- Move the transmission to position **N**.
- Try to bring the vehicle under control by using corrective steering.

**i** For more information on driving with snow chains, see (▷ page 320).

## Off-road driving

### Important safety notes

#### WARNING

If you drive up a steep incline at an angle or turn on a steep incline, the vehicle could slip sideways, tip and overturn. There is a risk of an accident.

When driving up an incline, drive into the line of fall (upwards or downwards in a straight line) and do not turn.

#### **G 350 BlueTEC:**

The level in the AdBlue® tank needs to be sufficiently high to compensate for driving at extreme angles when driving off-road.

Before driving off-road, make sure that the tank contains a minimum of ten litres.

When driving off-road, sand, mud and water, possibly mixed with oil, for example, could get into the brakes. This may lead to a reduction in braking performance or total brake failure as a result of increased wear. The braking characteristics will vary, depending on the substances that get into the brakes. Clean the brakes after driving off-road. If you notice grinding noises or a reduction in braking performance, have the brake system checked at a qualified specialist workshop immediately. Adapt your driving style to the altered braking characteristics.

Driving off-road increases the possibility of damage to the vehicle, which may cause assemblies or systems to fail. Adapt your driving style to the conditions of the terrain. Drive carefully. Have vehicle damage rectified immediately at a qualified specialist workshop.

Observe the following when on hilly roads:

- Do not shift the transmission to position **N**.
- If the gradient is too steep for your vehicle, back up in reverse gear.
- Do not continuously depress the brake pedal, as doing so could cause you to lose control.

### General notes

#### Environmental note

Protection of the environment is of primary importance. Treat nature with respect. Observe all prohibiting signs.

Read this section before driving your vehicle off-road. Practise by travelling over more gentle off-road terrain first.

The following driving systems are specially adapted to off-road driving:

- 4ETS (▷ page 62)
- Transfer case (▷ page 201)
- Differential locks (▷ page 204)

Observe the following notes:

- stop your vehicle and, if necessary, shift the transfer case to **LOW RANGE** (▷ page 202) before driving off-road.
- **AMG vehicles:** to shift the transfer case to **LOW RANGE**, deactivate the ECO start/stop function (▷ page 146).
- engage the differential locks, if necessary (▷ page 204)

 **i** ABS, 4ETS, ESP® and BAS are deactivated while the differential locks are engaged. This allows the front wheels to lock briefly, so that they can dig into a loose surface. However, please note that locked wheels skid and can no longer steer.

- Check that items of luggage and loads are stowed safely and are well secured (▷ page 271).
  - To avoid damaging the vehicle, make sure there is always sufficient ground clearance.
  - Always keep the engine running and in gear when driving on a downhill gradient.
  - Always keep the engine running and in gear when driving on a slope.
  - Drive slowly and evenly, if necessary at walking pace.
  - Ensure that the wheels are in contact with the ground at all times.
  - Drive with extreme care on unknown off-road routes where visibility is poor. For safety reasons, get out of the vehicle first and survey the off-road route.
  - Check the depth of water before fording rivers and streams.
  - When fording, do not stop and do not switch off the engine.
  - Look out for obstacles such as rocks, holes, tree stumps and furrows.
  - Always keep the doors, the rear door or tailgate (G-Class Cabriolet), the side windows and the sliding sunroof closed while the vehicle is in motion.
  - Switch off cruise control and variable SPEEDTRONIC.
  - Do not stray from marked routes or paths.
  - Adapt your speed to the terrain. The rougher, steeper or more ruts on the terrain, the slower your speed should be.
  - Drive slowly and at a constant speed through the water. Ensure that a bow wave does not form as you drive.
  - On sand, drive quickly to overcome the rolling resistance. Otherwise, the vehicle could dig itself into the sand.
  - Do not jump with the vehicle as this will interrupt the vehicle's propulsion.
  - Avoid high engine speeds. Drive at appropriate engine speeds.
  - Always check the vehicle for damage after off-road driving.
- i** Information about retrofitting special all-terrain tyres is available from any qualified specialist workshop.
- i** Do not use the HOLD function when driving off-road, on steep uphill or downhill gradients or on slippery or loose surfaces. The HOLD function cannot hold the vehicle on such surfaces.

### Checklist before driving off-road

- !** If the engine oil warning lamp lights up during the journey, stop the vehicle in a safe place as soon as is possible. Check the engine oil level. The warning given by the engine oil warning light must not be ignored. Continuing your journey when the symbol is shown may result in engine damage.
- ▶ **Engine oil level:** check the engine oil and top it up if necessary.  
Only then does the engine receive enough oil when the vehicle is standing on a steep incline.
  - ▶ **G 350 BlueTEC:** have the AdBlue® level checked at a qualified specialist workshop (▷ page 160).
  - ▶ **Tyre-change tool kit:** check that the jack is working and make sure you have the wheelbrace, a robust tow cable and a folding spade in the vehicle.
  - ▶ **Wheels and tyres:** check the tyre tread depth and tyre pressure.
  - ▶ Check for damage and remove any foreign objects, e.g. small stones, from the wheels/tyres.
  - ▶ Replace any missing valve caps.
  - ▶ Replace dented or damaged wheels.
  - ▶ Carry a sound spare wheel.

## Checklist after driving off-road

---

Driving over rough terrain places greater demands on your vehicle than driving on normal roads. After driving off-road, check the vehicle. This allows you to detect damage promptly and reduce the risk of an accident to yourself and other road users.

- ▶ Shift the transfer case to **HIGH RANGE**(▷ page 202).
- ▶ Disengage the differential locks (▷ page 204).
- ▶ Clean the headlamps and rear lights and check for damage.
- ▶ Clean the front and rear licence plates.
- ▶ Clean the wheels and tyres with a water jet and remove any foreign objects.
- ▶ Clean the wheels, tyres, wheel arches and the vehicle underside with a water jet; check for any foreign objects and damage.
- ▶ Check whether twigs or other parts of plants have become trapped. These increase the risk of fire and can damage fuel pipes, brake hoses or the rubber bellows of the axle joints and propeller shafts.
- ▶ After the trip, examine without fail the entire undercarriage, wheels, tyres, brakes, bodywork structure, steering, chassis and exhaust system for damage.
- ▶ After driving for extended periods across sand, mud, gravel, water or in similarly dirty conditions, have the brake discs, wheels, brake pads/linings and axle joints checked and cleaned.
- ▶ If you notice strong vibrations after off-road driving, check for foreign objects in the wheels and drive train and, if necessary, remove them. Foreign objects can disturb the balance and cause vibrations.

## Driving on sand

---

Observe the following rules when driving on sand:

- Shift the transfer case to **LOW RANGE**(▷ page 202).
- Avoid high engine speeds.
- Limit the shift range of the automatic transmission according to the off-road conditions.
- Drive quickly to overcome the rolling resistance. Otherwise, the vehicle could dig itself into the sand.
- Drive in the tracks of other vehicles if possible. Make sure that the ruts are not too deep, that the sand is firm enough and that your vehicle has sufficient ground clearance.

## Tyre ruts and gravel roads

---

- ❗ Check that the ruts are not too deep and that your vehicle has sufficient clearance. Otherwise, your vehicle could be damaged or bottom out and get stuck.

Observe the following rules when driving along ruts in off-road terrain or on roads with loose gravel:

- Shift the transfer case to **LOW RANGE**(▷ page 202).
- Avoid high engine speeds.
- Observe the safety notes (▷ page 169) and the general notes (▷ page 169) on off-road driving.
- Restrict the shift range of the automatic transmission to **1**(▷ page 153).
- Drive slowly.
- Where ruts are too deep, drive with the wheels on one side on the middle section of turf if possible.

## Driving over obstacles

---

- ❗ Obstacles could damage the floor of the vehicle or components of the chassis. Ask passengers for guidance when driving over

large obstacles. Any damage to the vehicle otherwise increases the risk of an accident.

- ❗ Drive with particular care when driving over an obstacle while driving up or down a steep slope.

The vehicle could otherwise tilt and slide sideways or tip over.



Observe the following rules when driving over tree stumps, large stones and other obstacles:

- Observe the safety notes (▷ page 169) and the general notes (▷ page 169) on off-road driving.
- Shift the transfer case to **LOW RANGE** (▷ page 202).
- Avoid high engine speeds.
- Restrict the shift range to **1** (▷ page 153).
- Make sure that you have enough ground clearance before driving across an obstacle.
- Drive very slowly.
- Try to drive straight over the centre of obstacles: front wheel first, then rear wheel.

## Travelling uphill

### Approach/departure angle



The table shows front approach/departure angles ① and rear approach/departure angles ② at maximum load. This information only provides an indication. The respective approach and departure angles vary according to the vehicle tyres and optional equipment.

	①	②
<b>G-Class long-wheel-base version</b>	36°	27°
<b>G 63 AMG</b>	28°	31°
<b>G 65 AMG</b>	28°	31°
<b>G-Class Cabriolet</b>	36°	27°

- Observe the safety notes (▷ page 169) and the general notes (▷ page 169) on off-road driving.
- Follow the line of fall when driving on slopes and steep inclines.
- Before driving on extreme uphill and downhill gradients, shift the transfer case to **LOW RANGE** (▷ page 202).
- Engage the differential locks, if necessary (▷ page 204).
- Drive slowly.

- Accelerate gently and make sure that the wheels are gripping.
- Avoid high engine speeds, except when driving on sandy and muddy routes with high driving resistance.
- When driving down a slope, use the braking power of the engine. Observe the engine speed; do not overrev the engine.
- Select a shift range appropriate to the gradient.
- Before tackling steep downhill gradients, select shift range 1 (▷ page 153).
- Always check the brakes after driving off-road.

### Maximum gradient-climbing capability

On good road surfaces and with the **LOW RANGE** gear selected, the maximum gradient-climbing capability is 80%.

- i** If the load on the front axle is reduced when pulling away on a steep uphill slope, the front wheels have a tendency to spin. 4ETS recognises this and brakes the wheels accordingly. The rear wheel torque is increased and it is easier to pull away.

### Hilltops

When driving up an uphill gradient, slightly reduce pressure on the accelerator immediately before reaching the brow of the hill. Make use of the vehicle's own impetus to travel over the brow.

This style of driving prevents:

- the vehicle from lifting off the ground on the brow of a hill
- loss of traction
- the vehicle from travelling too quickly down the other side.

### Driving downhill

- Before tackling steep downhill gradients, select shift range 1 (▷ page 153).

This way you use the engine's braking effect to reduce the speed. If this is not sufficient, brake gently. When doing so, make sure that the vehicle is facing in the direction of the line of fall.

- Observe the notes on driving in mountainous terrain (▷ page 173).
- Drive slowly.
- Do not drive at an angle down steep inclines. Steer into the line of fall and drive with the front wheels aligned straight. Otherwise, the vehicle could slip sideways, tip and overturn.
- Check that the brakes are working normally after a long downhill stretch.

## Driving systems

### Cruise control

### Important safety notes

#### WARNING

The brake pedal moves when cruise control brakes the vehicle. A foot in the area under the brake pedal could become trapped. The movement of the pedal, and therefore the vehicle's ability to brake, may be restricted by objects in the area under the brake. There is a risk of an accident and injury.

Do not place your foot under the brake pedal. Keep the area under the brake pedal free from obstructions.

If you fail to adapt your driving style, cruise control can neither reduce the risk of accident nor override the laws of physics. Cruise control cannot take account of road, weather and traffic conditions. Cruise control is only an aid. You are responsible for the distance to the vehicle in front, for vehicle speed and for braking in good time. Adjust your driving style to the traffic conditions. Only engage cruise control when the current road, weather and traffic conditions permit it to be done safely. Drive carefully and maintain a suitable distance to the vehicle in front.

Do not use cruise control:

- in traffic conditions that do not allow you to drive at a constant speed, e.g. heavy traffic, on winding roads or off-road
- on slippery road surfaces. Braking or accelerating could cause the drive wheels to lose traction and the vehicle could then skid.
- when there is poor visibility, e.g. due to fog, heavy rain or snow

### General notes

Cruise control maintains a constant road speed for you. On long and steep downhill gradients, especially if the vehicle is laden or towing a trailer, you must select shift range **1**, **2** or **3** in good time. By doing so, you will make use of the braking effect of the engine. This relieves the load on the brake system and prevents the brakes from overheating and wearing too quickly.

Use cruise control only if road and traffic conditions make it appropriate to maintain a steady speed for a prolonged period. You can store any road speed above 30 km/h.

### Cruise control lever

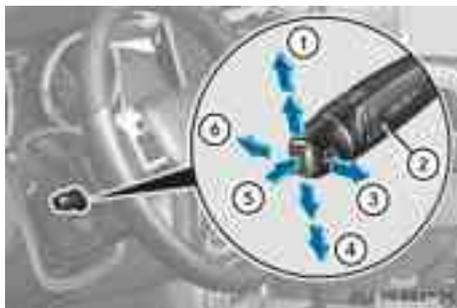

- ① To activate or increase speed
- ② LIM indicator lamp
- ③ To activate at the current speed/last stored speed
- ④ To activate or reduce speed
- ⑤ To switch between cruise control and variable SPEEDTRONIC
- ⑥ To deactivate cruise control

You can operate cruise control and variable SPEEDTRONIC with the cruise control lever. When you activate cruise control, the stored speed is shown in the multifunction display for five seconds.

If an AdBlue® display message is shown in the multifunction display, you will no longer be able to use the full range of cruise control functions.

The full range of cruise control functions will become available again once you confirm the AdBlue® display message:

- ▶ Briefly press the , , or button on the multifunction steering wheel.

or

- ▶ Briefly press the reset button on the instrument cluster.

The LIM indicator lamp on the cruise control lever indicates which system you have selected:

- **LIM indicator lamp off:** cruise control is selected.
- **LIM indicator lamp on:** variable SPEEDTRONIC is selected.

### Activation conditions

To activate cruise control, all of the following activation conditions must be fulfilled:

- the parking brake must be released.
- you are driving faster than 30 km/h.
- ESP® must be switched on, but not intervening.
- the transmission must be in position **D**.
- the cruise control function must be selected (▷ page 175).

## Selecting cruise control

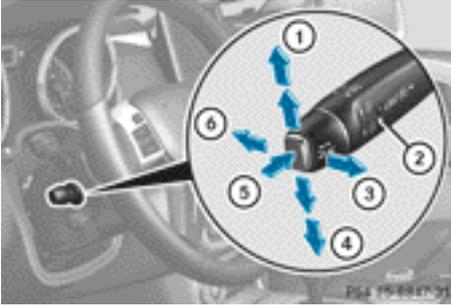

- ① To activate or increase speed
- ② LIM indicator lamp
- ③ To activate at the current speed/last stored speed
- ④ To activate or reduce speed
- ⑤ To switch between cruise control and variable SPEEDTRONIC
- ⑥ To deactivate cruise control

- ▶ Check whether LIM indicator lamp ② is off. If it is off, cruise control is already selected. If it is not, press the cruise control lever in the direction of arrow ⑤. LIM indicator lamp ② in the cruise control lever goes out. Cruise control is selected.

## Storing and maintaining the current speed

### Storing and maintaining

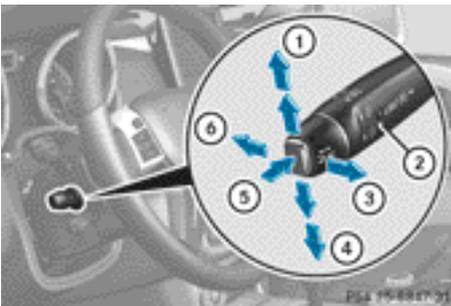

- ① To activate or increase speed
- ② LIM indicator lamp

- ③ To activate at the current speed/last stored speed
- ④ To activate or reduce speed
- ⑤ To switch between cruise control and variable SPEEDTRONIC
- ⑥ To deactivate cruise control

You can store the current speed if you are driving faster than 30 km/h.

- ▶ Accelerate the vehicle to the desired speed.
- ▶ Briefly press the cruise control lever up ① or down ④.
- ▶ Remove your foot from the accelerator pedal. Cruise control is activated. The vehicle automatically maintains the stored speed.

- ⓘ Cruise control may be unable to maintain the stored speed on uphill and downhill gradients. The stored speed is resumed when the gradient levels out. Cruise control maintains the stored speed on downhill gradients by automatically applying the brakes.

## Calling up the last speed stored

### ⚠ WARNING

If you call up the stored speed and it is lower than the current speed, the vehicle decelerates. If you do not know the stored speed, the vehicle could decelerate unexpectedly. There is a risk of an accident.

Pay attention to the road and traffic conditions before calling up the stored speed. If you do not know the stored speed, store the desired speed again.

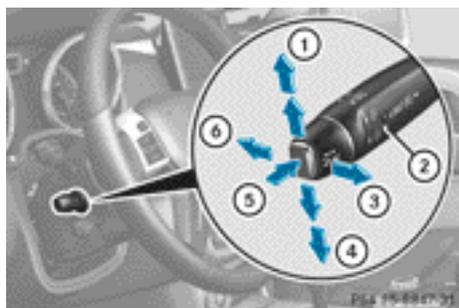

- ① To activate or increase speed
- ② LIM indicator lamp
- ③ To activate at the current speed/last stored speed
- ④ To activate or reduce speed
- ⑤ To switch between cruise control and variable SPEEDTRONIC
- ⑥ To deactivate cruise control

▶ Briefly pull the cruise control lever towards you ③.

▶ Remove your foot from the accelerator pedal. Cruise control is activated and adjusts the vehicle's speed to the last speed stored.

**i** If no speed is stored, cruise control stores the current speed and maintains it.

### Calling up the last speed stored

#### Storing and maintaining

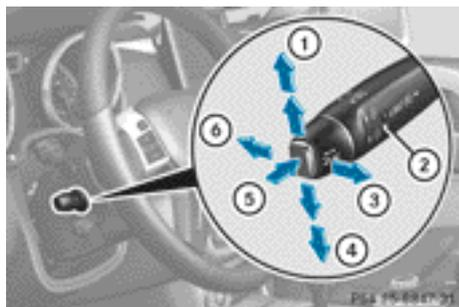

- ① To activate or increase speed
- ② LIM indicator lamp

- ③ To activate at the current speed/last stored speed
- ④ To activate or reduce speed
- ⑤ To switch between cruise control and variable SPEEDTRONIC
- ⑥ To deactivate cruise control

You can store the current speed if you are driving faster than 30 km/h.

▶ Accelerate the vehicle to the desired speed.

▶ Briefly press the cruise control lever up ① or down ④.

▶ Remove your foot from the accelerator pedal. Cruise control is activated. The vehicle automatically maintains the stored speed.

**i** Cruise control may be unable to maintain the stored speed on uphill and downhill gradients. The stored speed is resumed when the gradient levels out. Cruise control maintains the stored speed on downhill gradients by automatically applying the brakes.

### Calling up the last speed stored

#### **⚠** WARNING

If you call up the stored speed and it is lower than the current speed, the vehicle decelerates. If you do not know the stored speed, the vehicle could decelerate unexpectedly. There is a risk of an accident.

Pay attention to the road and traffic conditions before calling up the stored speed. If you do not know the stored speed, store the desired speed again.

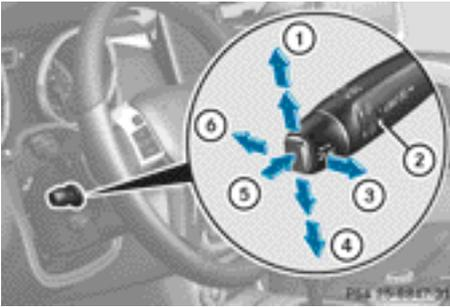

- ① To activate or increase speed
- ② LIM indicator lamp
- ③ To activate at the current speed/last stored speed
- ④ To activate or reduce speed
- ⑤ To switch between cruise control and variable SPEEDTRONIC
- ⑥ To deactivate cruise control

► Briefly pull the cruise control lever towards you ③.

► Remove your foot from the accelerator pedal. Cruise control is activated and adjusts the vehicle's speed to the last speed stored.

❗ If no speed is stored, cruise control stores the current speed and maintains it.

### Setting a speed

#### Adjusting

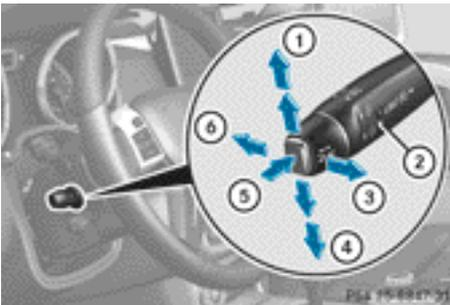

- ① To activate or increase speed
- ② LIM indicator lamp

- ③ To activate at the current speed/last stored speed
- ④ To activate or reduce speed
- ⑤ To switch between cruise control and variable SPEEDTRONIC
- ⑥ To deactivate cruise control

Keep in mind that it may take a brief moment until the vehicle accelerates or decelerates to the set speed.

► **To increase the speed:** press the cruise control lever up ①.

► **To decrease the speed:** press the cruise control lever down ④.

► Keep the cruise control lever pressed until the desired speed is reached.

► Release the cruise control lever. The new speed is stored.

### Making adjustments in 1 km/h increments

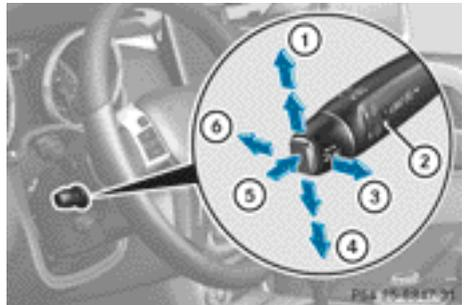

- ① To activate or increase speed
- ② LIM indicator lamp
- ③ To activate at the current speed/last stored speed
- ④ To activate or reduce speed
- ⑤ To switch between cruise control and variable SPEEDTRONIC
- ⑥ To deactivate cruise control

► Briefly press the cruise control lever up ① for a higher speed or down ④ for a lower speed. The last speed stored is increased or reduced.

### Making adjustments in 10 km/h increments

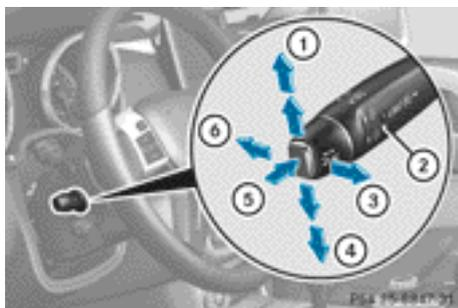

- ① To activate or increase speed
- ② LIM indicator lamp
- ③ To activate at the current speed/last stored speed
- ④ To activate or reduce speed
- ⑤ To switch between cruise control and variable SPEEDTRONIC
- ⑥ To deactivate cruise control

- ▶ Briefly press the cruise control lever up ① or down ④ to beyond the pressure point.  
The last stored speed increases or decreases in 10 km/h increments.

### Deactivating cruise control

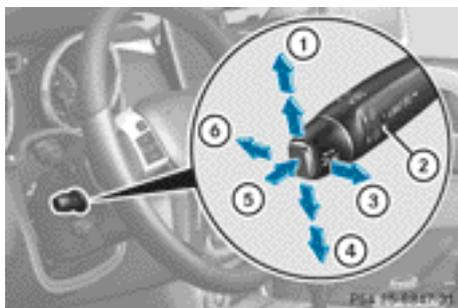

- ① To activate or increase speed
- ② LIM indicator lamp
- ③ To activate at the current speed/last stored speed
- ④ To activate or reduce speed

- ⑤ To switch between cruise control and variable SPEEDTRONIC

- ⑥ To deactivate cruise control

There are several ways to deactivate cruise control:

- ▶ Briefly press the cruise control lever forwards ⑥.

or

- ▶ Brake.

or

- ▶ Briefly press the cruise control lever in the direction of arrow ⑤.

Variable SPEEDTRONIC is selected. LIM indicator lamp ② in the cruise control lever lights up.

Cruise control is automatically deactivated if:

- you apply the parking brake.
- you are driving at less than 30 km/h.
- ESP® intervenes or you deactivate ESP®.
- you shift the transmission to position **N** while driving.
- **G 350 BlueTEC**: you engage a differential lock.

- ❗ The last speed stored is cleared when you switch off the engine.

### SPEEDTRONIC

#### Important safety notes

##### ⚠ WARNING

The braking system can overheat if you leave your foot on the brake pedal while driving. This increases the braking distance and could even cause the braking system to fail. There is a risk of an accident.

Never use the brake pedal as a footrest. Do not simultaneously depress both the brake pedal and the accelerator pedal while driving.

- ❗ Depressing the brake pedal constantly results in excessive and premature wear to the brake pads.

If you fail to adapt your driving style, SPEEDTRONIC can neither reduce the risk of accident nor override the laws of physics. SPEEDTRONIC cannot take account of road, weather and traffic conditions. SPEEDTRONIC is only an aid. You are responsible for the distance to the vehicle in front, for vehicle speed, for braking in good time and for staying in lane. Only engage SPEEDTRONIC when the current road, weather and traffic conditions permit it to be done safely. Drive carefully and maintain a suitable distance to the vehicle in front.

### General notes

SPEEDTRONIC brakes automatically so that you do not exceed the set speed. On long and steep downhill gradients, especially if the vehicle is laden or towing a trailer, you must select shift range **1, 2 or 3** in good time. By doing so, you will make use of the braking effect of the engine. This relieves the load on the brake system and prevents the brakes from overheating and wearing too quickly. If you need additional braking, depress the brake pedal repeatedly rather than continuously.

- i** The speed indicated in the speedometer may differ slightly from the limit speed stored.

### Cruise control lever

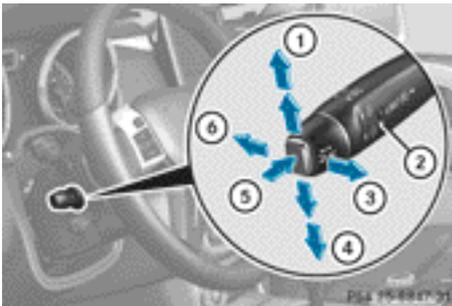

- ① To store the current speed or a higher speed
- ② LIM indicator lamp
- ③ To call up the last speed stored

- ④ To store the current speed or a lower speed
- ⑤ To switch between cruise control and variable SPEEDTRONIC
- ⑥ To deactivate variable SPEEDTRONIC

You can operate cruise control and variable SPEEDTRONIC with the cruise control lever. The LIM indicator lamp on the cruise control lever indicates which system you have selected:

- **LIM indicator lamp off:** cruise control is selected.
- **LIM indicator lamp on:** variable SPEEDTRONIC is selected.

You can use the cruise control lever to limit the speed to any speed above 30 km/h while the engine is running.

### Selecting variable SPEEDTRONIC

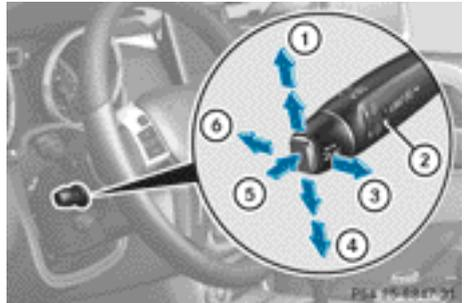

- ① To activate or increase speed
- ② LIM indicator lamp
- ③ To activate at the current speed/last stored speed
- ④ To activate or reduce speed
- ⑤ To switch between cruise control and variable SPEEDTRONIC
- ⑥ To deactivate cruise control

If you fail to adapt your driving style, SPEEDTRONIC can neither reduce the risk of accident nor override the laws of physics. SPEEDTRONIC cannot take account of road, weather and traffic conditions. SPEEDTRONIC is only an aid. You are responsible for the distance

to the vehicle in front, for vehicle speed, for braking in good time and for staying in lane. Only engage SPEEDTRONIC when the current road, weather and traffic conditions permit it to be done safely. Drive carefully and maintain a suitable distance to the vehicle in front.

► Check whether LIM indicator lamp ② is on.

If it is on, variable SPEEDTRONIC is already selected.

If it is not, press the cruise control lever in the direction of arrow ⑤.

LIM indicator lamp ② in the cruise control lever lights up. Variable SPEEDTRONIC is selected.

### Storing the current speed

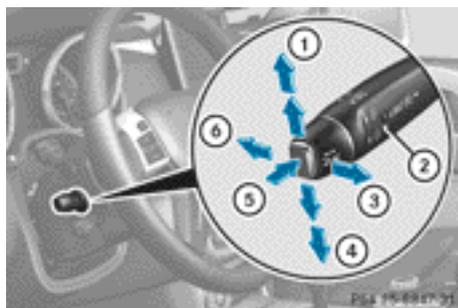

- ① To activate or increase speed
- ② LIM indicator lamp
- ③ To activate at the current speed/last stored speed
- ④ To activate or reduce speed
- ⑤ To switch between cruise control and variable SPEEDTRONIC
- ⑥ To deactivate cruise control

You can use the cruise control lever to limit the speed to any speed above 30 km/h while the engine is running.

► Briefly press the cruise control lever up ① or down ④.

The current speed is stored and shown in the multifunction display.

❗ On downhill gradients, the speed can be exceeded despite variable SPEEDTRONIC.

If this is the case, you will hear a warning tone and the **Limit exceeded** (or **Limit** for the G 350 BlueTEC) message appears in the multifunction display. Apply the brakes yourself if required.

### Calling up the last speed stored

#### Calling up the last speed stored

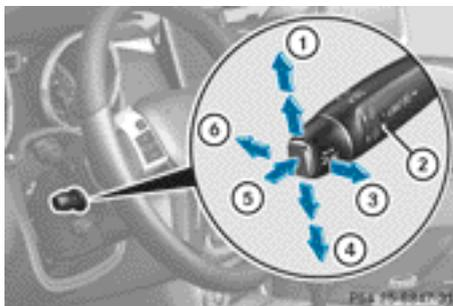

- ① To activate or increase speed
- ② LIM indicator lamp
- ③ To activate at the current speed/last stored speed
- ④ To activate or reduce speed
- ⑤ To switch between cruise control and variable SPEEDTRONIC
- ⑥ To deactivate cruise control

If you fail to adapt your driving style, SPEEDTRONIC can neither reduce the risk of accident nor override the laws of physics. SPEEDTRONIC cannot take account of road, weather and traffic conditions. SPEEDTRONIC is only an aid. You are responsible for the distance to the vehicle in front, for vehicle speed, for braking in good time and for staying in lane. Only engage SPEEDTRONIC when the current road, weather and traffic conditions permit it to be done safely. Drive carefully and maintain a suitable distance to the vehicle in front.

► Briefly pull the cruise control lever towards you ③.

❗ If you call up the stored speed and your current speed is higher, you will hear a warning tone. The **Limit exceeded** (or

Limit in the G 350 CDI) message will appear in the multifunction display.

- ❶ If no speed is stored, variable SPEEDTRONIC stores the current speed and maintains it.

### Making adjustments in 1 km/h increments

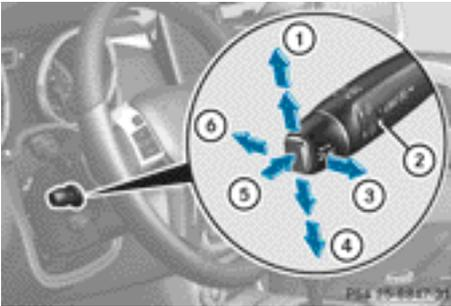

- ❶ To activate or increase speed
- ❷ LIM indicator lamp
- ❸ To activate at the current speed/last stored speed
- ❹ To activate or reduce speed
- ❺ To switch between cruise control and variable SPEEDTRONIC
- ❻ To deactivate cruise control

► **For a higher speed:** briefly pull the cruise control lever towards you ❸.

or

► Keep the cruise control lever pulled towards you ❸ until the desired speed is set.

### Making adjustments in 10 km/h increments

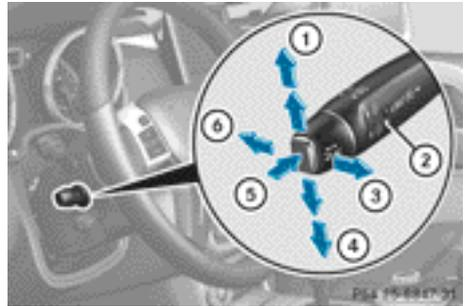

- ❶ To activate or increase speed
- ❷ LIM indicator lamp
- ❸ To activate at the current speed/last stored speed
- ❹ To activate or reduce speed
- ❺ To switch between cruise control and variable SPEEDTRONIC
- ❻ To deactivate cruise control

► Briefly press the cruise control lever up ❶ for a higher speed or down ❹ for a lower speed.

or

► Keep the cruise control lever pressed until the desired speed is set. Press the cruise control lever up ❶ for a higher speed or down ❹ for a lower speed.

### Deactivating variable SPEEDTRONIC

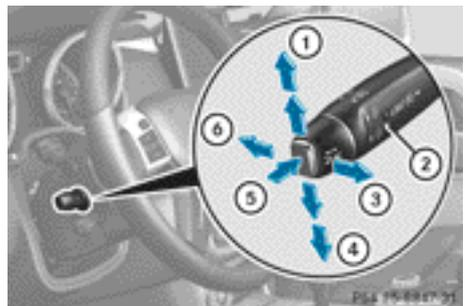

There are several ways to deactivate variable SPEEDTRONIC:

▶ Briefly press the cruise control lever forwards .

or

▶ Briefly press the cruise control lever in the direction of arrow .

LIM indicator lamp  in the cruise control lever goes out. Variable SPEEDTRONIC is deactivated.

Cruise control is selected.

It is not possible to deactivate variable SPEEDTRONIC by braking.

Variable SPEEDTRONIC is deactivated automatically if you depress the accelerator pedal beyond the pressure point (kickdown), but only if your current speed does not differ by more than 20 km/h from the stored speed. G 350 BlueTEC: you will hear a warning tone.

### Permanent SPEEDTRONIC

You can use the on-board computer to limit the speed permanently to a value between 160 km/h (e.g. for driving on winter tyres) and the maximum speed (> page 223).

Shortly before the stored speed is reached, it appears in the multifunction display.

Permanent SPEEDTRONIC remains active, even if variable SPEEDTRONIC is deactivated.

You cannot exceed the stored limit speed, even if you depress the accelerator pedal beyond the pressure point (kickdown).

### DISTRONIC PLUS

#### Important safety notes

##### WARNING

DISTRONIC PLUS does not react to:

- people or animals
- stationary obstacles on the road, e.g. stopped or parked vehicles
- oncoming and crossing traffic

As a result, DISTRONIC PLUS may neither give warnings nor intervene in such situations.

There is a risk of an accident.

Always pay careful attention to the traffic situation and be ready to brake.

##### WARNING

DISTRONIC PLUS cannot always clearly identify other road users and complex traffic situations.

In such cases, DISTRONIC PLUS may:

- give an unnecessary warning and then brake the vehicle
- neither give a warning nor intervene
- accelerate unexpectedly

There is a risk of an accident.

Continue to drive carefully and be ready to brake, in particular when warned to do so by DISTRONIC PLUS.

##### WARNING

DISTRONIC PLUS brakes your vehicle with up to 40% of the maximum braking force. If this braking force is insufficient, DISTRONIC PLUS warns you visually and audibly. There is a risk of an accident.

In such cases, apply the brakes yourself and try to take evasive action.

If you fail to adapt your driving style, DISTRONIC PLUS can neither reduce the risk of accident nor override the laws of physics. DISTRONIC PLUS cannot take account of road, weather and traffic conditions. DISTRONIC PLUS is only an aid. You are responsible for the distance to the vehicle in front, for vehicle speed, for braking in good time and for staying in lane. Only engage DISTRONIC PLUS when the current road, weather and traffic conditions permit it to be done safely, and adapt your driving style accordingly. Drive carefully and maintain a suitable distance to the vehicle in front.

If DISTRONIC PLUS detects a risk of collision but cannot sufficiently decelerate the vehicle in order to maintain the set distance, you will

be warned visually and acoustically. DISTRONIC PLUS cannot prevent a collision without your intervention. An intermittent warning tone will then sound and the distance warning lamp will light up in the instrument cluster. Brake immediately in order to increase the distance from the vehicle in front, or take evasive action, provided it is safe to do so.

DISTRONIC PLUS may not detect narrow vehicles driving in front, e.g. motorcycles, or vehicles driving on a different line. Therefore, always pay attention to traffic conditions even when DISTRONIC PLUS is activated. Otherwise, you may fail to recognise dangers in time, cause an accident and injure yourself and others.

If DISTRONIC PLUS is activated, the vehicle brakes automatically in certain situations. This can happen unexpectedly, especially when towing or in a car wash. There is a risk of an accident. In these or similar situations, deactivate DISTRONIC PLUS.

If you want DISTRONIC PLUS to assist you, the following activation conditions must be fulfilled (▷ page 184) and the radar sensor system must be operational.

### General notes

DISTRONIC PLUS regulates the speed and automatically helps you maintain the distance to the vehicle detected in front. DISTRONIC PLUS brakes automatically so that the set speed is not exceeded.

On long and steep downhill gradients, especially if the vehicle is laden or towing a trailer, you must select shift range **1**, **2** or **3** in good time. By doing so, you will make use of the braking effect of the engine. This relieves the load on the brake system and prevents the brakes from overheating and wearing too quickly.

If DISTRONIC PLUS detects a slower-moving vehicle in front, your vehicle is braked in order to maintain the preset distance to the vehicle in front.

If there is no vehicle in front, DISTRONIC PLUS operates in the same way as cruise control in the speed range between 30 km/h and 200 km/h. If a vehicle is driving in front of you, DISTRONIC operates in the speed range between 0 km/h and 200 km/h.

Do not use DISTRONIC PLUS on roads with steep gradients.

### Cruise control lever



- ① To activate or increase speed
- ② To set the specified minimum distance
- ③ LIM indicator lamp
- ④ To activate at the current speed/last stored speed
- ⑤ To activate or reduce speed
- ⑥ To switch between DISTRONIC PLUS and variable SPEEDTRONIC
- ⑦ To deactivate DISTRONIC PLUS

With the cruise control lever, you can operate DISTRONIC PLUS and variable SPEEDTRONIC.

- **To switch between variable SPEEDTRONIC and DISTRONIC PLUS:** press the

cruise control lever in the direction of arrow ⑥.

LIM indicator lamp ③ on the cruise control lever indicates which function you have selected:

- **LIM indicator lamp ③ off:** DISTRONIC PLUS is selected.
- **LIM indicator lamp ③ on:** variable SPEEDTRONIC is selected.

### Activating DISTRONIC PLUS

#### Activation conditions

To activate DISTRONIC PLUS, the following conditions must be fulfilled:

- the engine must be running. It may take up to two minutes of driving before DISTRONIC PLUS is ready for use.
- the parking brake must be released.
- the differential lock must be deactivated.
- ESP® must be switched on, but not intervening.
- the transmission must be in position **D**.
- the driver's door must be closed when you shift from **P** to **D** or your seat belt must be fastened.
- the front-passenger door and the rear doors must be closed.
- the vehicle must not be skidding.
- the DISTRONIC PLUS function must be selected (▷ page 183).
- the transfer case must be in the **HIGH RANGE** transmission position.
- the vehicle must not be on an uphill or downhill gradient of more than 22-25%.
- the radar sensor must be free from dirt (▷ page 294).

### Activating while driving

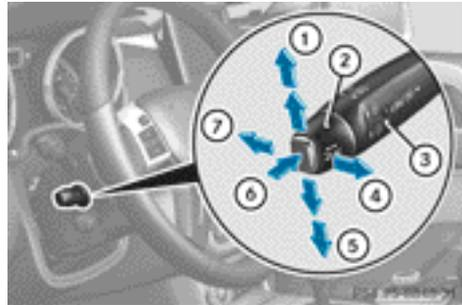

When driving at speeds below 30 km/h, you can activate DISTRONIC PLUS if the vehicle in front has been detected and is shown in the multifunction display. If the vehicle in front is no longer detected and displayed, DISTRONIC PLUS switches off and you will hear a tone.

- ▶ Briefly pull the cruise control lever towards you ④, or press it up ① or down ⑤. DISTRONIC PLUS is selected.
- ▶ Press the cruise control lever up ① or down ⑤ repeatedly until the desired speed is set.
- ▶ Remove your foot from the accelerator pedal. Your vehicle adapts its speed to that of the vehicle in front, but only up to the desired stored speed.

**i** If you do not fully release the accelerator pedal, the **DISTRONIC PLUS inactive** message appears in the multifunction display. The set distance to a slower-moving vehicle in front will then not be maintained. You will be driving at the speed you determine by the position of the accelerator pedal.

### Switching on while stationary

This function may be useful if you want to keep up with the traffic flow, e.g. at the end of a tailback.

You can only activate DISTRONIC PLUS if:

- the vehicle in front and
  - your vehicle are stationary
- Briefly pull the cruise control lever towards you ④, or press it up ① or down ⑤. DISTRONIC PLUS is selected.
- i** DISTRONIC PLUS can be activated at a standstill and at speeds below 30 km/h only if a vehicle in front has been detected. Therefore, the DISTRONIC PLUS distance display in the instrument cluster should be activated (▷ page 220).
- Keep the cruise control lever pressed up ① or down ⑤ until the desired speed is set.
- i** You can use the cruise control lever to set the stored speed and the control on the cruise control lever to set the specified minimum distance (▷ page 188).

### Activating at the current speed/last stored speed

#### WARNING

If you call up a stored speed and this is different from the current speed, the vehicle accelerates or brakes. If you do not know what the stored speed is, the vehicle may accelerate or brake unexpectedly. There is a risk of an accident.

Take the traffic conditions into account before calling up the stored speed. If you do not know what the stored speed is, store the desired speed again.

- Briefly pull the cruise control lever towards you ④.
- Remove your foot from the accelerator pedal. DISTRONIC PLUS is activated. The first time it is activated, the current speed is

stored. Otherwise, it sets the vehicle cruise speed to the previously stored value.

## Driving with DISTRONIC PLUS

### Pulling away and driving

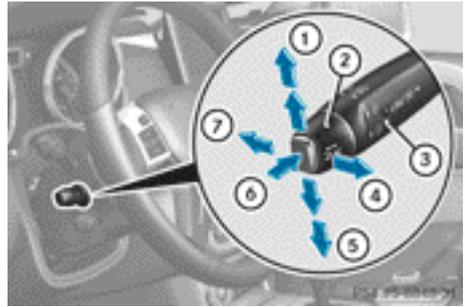

- **If the vehicle in front pulls away:** remove your foot from the brake pedal.
- Briefly pull the cruise control lever towards you ④, or press it up ① or down ⑤.
- or
- Accelerate briefly. Your vehicle pulls away and adapts its speed to that of the vehicle in front.

If there is no vehicle in front, DISTRONIC PLUS operates in the same way as cruise control.

If DISTRONIC PLUS detects that the vehicle in front has slowed down, it brakes your vehicle. In this way, the distance you have selected is maintained.

If DISTRONIC PLUS detects that the vehicle in front is driving faster, it accelerates your vehicle, but only up to the speed you have stored.

If you depress the brake, DISTRONIC PLUS is deactivated unless your vehicle is stationary.

### Changing lanes

If you change to the overtaking lane, DISTRONIC PLUS supports you if:

- you are driving faster than 60 km/h.
- DISTRONIC PLUS is maintaining the distance to a vehicle in front.

- you switch on the respective turn signals.
- DISTRONIC PLUS does not detect a danger of collision.

If these conditions are met, your vehicle is accelerated. Acceleration will be interrupted if changing lanes takes too long or if the distance between your vehicle and the vehicle in front becomes too small.

- i** When changing lanes, DISTRONIC PLUS monitors the left lane for left-hand-drive vehicles and the right lane for right-hand-drive vehicles.

### Stopping

#### WARNING

When leaving the vehicle, even if it is braked only by DISTRONIC PLUS, it could roll away if:

- there is a malfunction in the system or in the voltage supply.
- DISTRONIC PLUS has been deactivated with the cruise control lever, e.g. by a vehicle occupant or from outside the vehicle.
- the electrical system in the engine compartment, the battery or the fuses have been tampered with.
- the battery is disconnected.
- the accelerator pedal has been depressed, e.g. by a vehicle occupant.

There is a risk of an accident.

If you wish to exit the vehicle, always turn off DISTRONIC PLUS and secure the vehicle against rolling away.

If DISTRONIC PLUS detects that the vehicle in front is stopping, it brakes your vehicle until it is stationary.

Once your vehicle is stationary, it remains stationary and you do not need to depress the brake.

- i** Depending on the specified minimum distance, your vehicle will come to a standstill at a sufficient distance behind the vehicle in front. The specified minimum distance is set using the control on the cruise control lever.

On steep uphill or downhill gradients or if there is a malfunction, the transmission may also be automatically shifted into position **P**.

### Displays in the instrument cluster

#### Displays in the speedometer



Example: DISTRONIC PLUS displays in the speedometer

When DISTRONIC PLUS is activated, one or two segments **②** in the set speed range light up.

If DISTRONIC PLUS detects a vehicle in front, segments **②** between speed of the vehicle in front **①** and stored speed **③** light up.

- i** For design reasons, the speed displayed in the speedometer may differ slightly from the speed set for DISTRONIC PLUS.

### Display when DISTRONIC PLUS is deactivated



Distance display when DISTRONIC PLUS is deactivated

- ① Vehicle in front, if detected
- ② Distance indicator: current distance to the vehicle in front
- ③ Specified minimum distance to the vehicle in front; adjustable
- ④ Own vehicle

In the Assistance menu (▷ page 220) of the on-board computer, you can select the distance display.

- ▶ Select the **Distance display** function using the on-board computer.

### Display when DISTRONIC PLUS is activated



Distance display with DISTRONIC PLUS activated in the multifunction display

- ① DISTRONIC PLUS activated
- ② Own vehicle

- ③ Specified minimum distance to the vehicle in front; adjustable
- ④ Vehicle in front, if detected

In the Assistance menu (▷ page 220) of the on-board computer, you can select the distance display.

- ▶ Select the **Distance display** function using the on-board computer (▷ page 220).

You will see the stored speed for about five seconds when you activate DISTRONIC PLUS.

### Setting a speed

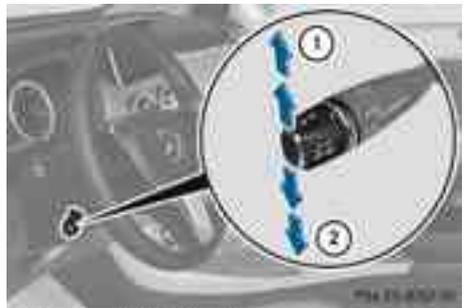

- ① To store the current speed or a higher speed
- ② To store the current speed or a lower speed

- ▶ Press the cruise control lever up ① for a higher speed or down ② for a lower speed.
- ▶ Keep the cruise control lever pressed until the desired speed is reached.
- ▶ Release the cruise control lever. The new speed is stored. DISTRONIC PLUS is activated and adjusts the vehicle's speed to the new speed stored.
- ▶ **To adjust the set speed in 1 km/h increments:** briefly press the cruise control lever up ① or down ② to the pressure point. The last speed stored is increased or reduced in 1 km/h increments.
- ▶ **To adjust the set speed in 10 km/h increments:** press the cruise control lever

briefly up ① or down ② beyond the pressure point.

The last stored speed increases or decreases in 10 km/h increments.

- i** DISTRONIC PLUS is not deactivated if you depress the accelerator pedal. If you accelerate to overtake, DISTRONIC PLUS adjusts the vehicle's speed to the last speed stored after you have finished overtaking.

### Setting the specified minimum distance



You can set the specified minimum distance for DISTRONIC PLUS by varying the time span between one and two seconds. With this function, you can set the minimum distance that DISTRONIC PLUS keeps to the vehicle in front, dependent on vehicle speed. You can see this distance in the multifunction display (▷ page 220).

- ▶ **To increase:** turn control ③ in direction ②. DISTRONIC PLUS then maintains a greater distance between your vehicle and the vehicle in front.
  - ▶ **To decrease:** turn control ③ in direction ①. DISTRONIC PLUS then maintains a shorter distance between your vehicle and the vehicle in front.
- i** Make sure that you maintain the minimum distance to the vehicle in front as required by law. Adjust the distance to the vehicle in front if necessary.

### Deactivating DISTRONIC PLUS

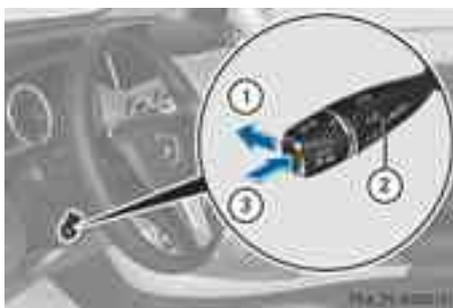

There are several ways to deactivate DISTRONIC PLUS:

- ▶ Briefly press the cruise control lever forwards ①.
- or
- ▶ Brake, unless the vehicle is stationary.
- or
- ▶ Briefly press the cruise control lever in the direction of arrow ③. Variable SPEEDTRONIC is selected. LIM indicator lamp ② in the cruise control lever lights up.

When you deactivate DISTRONIC PLUS, you will see the **DISTRONIC PLUS off** message in the multifunction display for approximately five seconds.

- i** The last speed stored remains stored until you switch off the engine.

DISTRONIC PLUS is automatically deactivated if:

- you engage the parking brake.
- you are driving more slowly than 25 km/h and there is no longer a vehicle in front, or if the vehicle in front is no longer detected
- ESP® intervenes or you deactivate ESP®
- the transmission is in the **P**, **R** or **N** position.
- the vehicle is near a radio telescope facility (▷ page 347).
- you pull the cruise control lever towards you in order to pull away, and the front-

passenger door or one of the rear doors is open.

- the vehicle has skidded.

If DISTRONIC PLUS is deactivated, you will hear a warning tone. You will see the **DIS-TRONIC PLUS off** message in the multifunction display for approximately five seconds.

In the Assistance menu (▷ page 220) of the on-board computer, you can select the distance display.

### Tips for driving with DISTRONIC PLUS

#### General notes

The following contains descriptions of certain road and traffic conditions in which you must be particularly attentive. In such situations, brake if necessary. DISTRONIC PLUS is then deactivated.

#### Cornering, going into and coming out of a bend

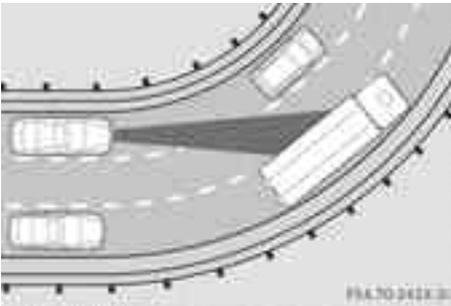

The ability of DISTRONIC PLUS to detect vehicles when cornering is limited. Your vehicle may brake unexpectedly or late.

#### Vehicles that are not driving in the middle of their lane

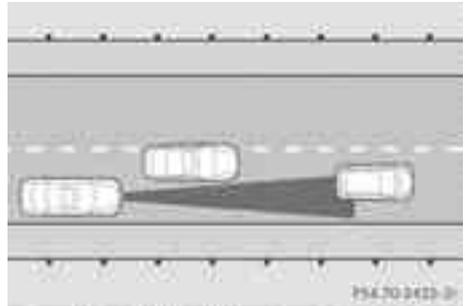

DISTRONIC PLUS may not detect vehicles which are not driving in the middle of their lane. The distance to the vehicle in front will be too short.

#### Other vehicles changing lane

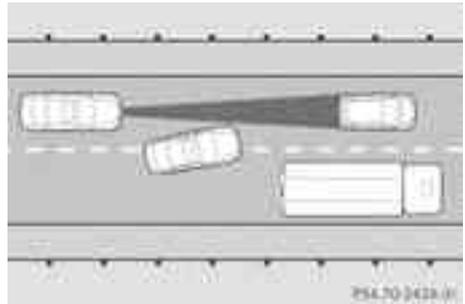

DISTRONIC PLUS has not detected the vehicle cutting in yet. The distance to this vehicle will be too short.

#### Narrow vehicles

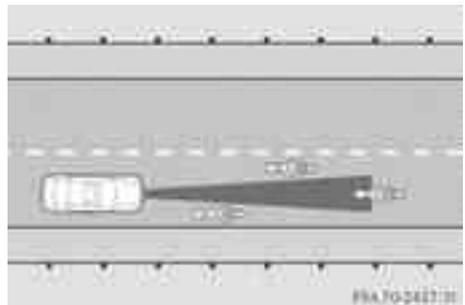

DISTRONIC PLUS has not yet detected the vehicle in front on the edge of the carriageway, because of its narrow width. The distance to the vehicle in front will be too short.

### Obstructions and stationary vehicles

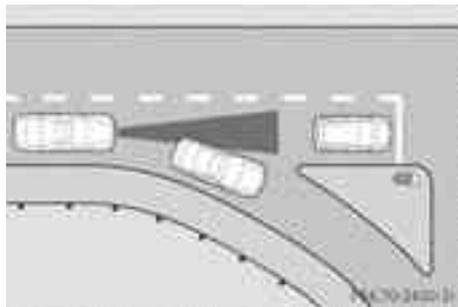

DISTRONIC PLUS does not brake for obstacles or stationary vehicles. If, for example, the detected vehicle turns a corner and reveals an obstacle or stationary vehicle, DISTRONIC PLUS will not brake for these.

### Crossing vehicles

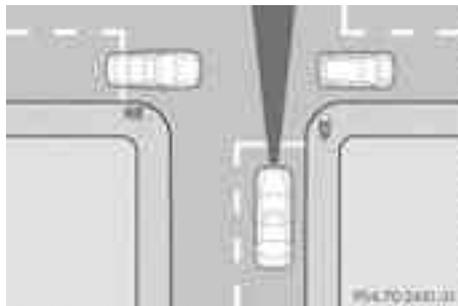

DISTRONIC PLUS may detect vehicles that are crossing your lane by mistake. Activating DISTRONIC PLUS at traffic lights with crossing traffic, for example, could cause your vehicle to pull away unintentionally.

## Blind Spot Assist

### Important safety notes

#### WARNING

Blind Spot Assist does not react to:

- vehicles overtaken too closely on the side, placing them in the blind spot area
- vehicles approaching and driving by with a speed difference of more than approximately 11 km/h

As a result, Blind Spot Assist may not give warnings in such situations. There is a risk of an accident.

Always observe the traffic conditions carefully, and maintain a safe lateral distance.

Blind Spot Assist is only an aid. It may fail to detect some vehicles and is no substitute for attentive driving.

In particular, the detection of obstacles can be impaired if there is:

- dirt on the sensors or anything else covering the sensors
- visibility is poor, e.g. due to fog, heavy rain or snow
- there is a narrow vehicle travelling in front, e.g. a motorcycle or bicycle
- the road has very wide lanes
- the road has narrow lanes
- you are not driving in the middle of the lane
- there are barriers or other road boundaries

### General notes

Blind Spot Assist uses a radar sensor system to monitor both the left and right sides of your vehicle. It supports you from speeds of 30 km/h. A warning display in the exterior mirrors draws your attention to vehicles detected in the monitored area. If you then switch on the corresponding turn signal to change lane, you will also receive an optical and audible collision warning. For this purpose, Blind Spot Assist uses sensors in the rear bumper.

## Monitoring range of the sensors

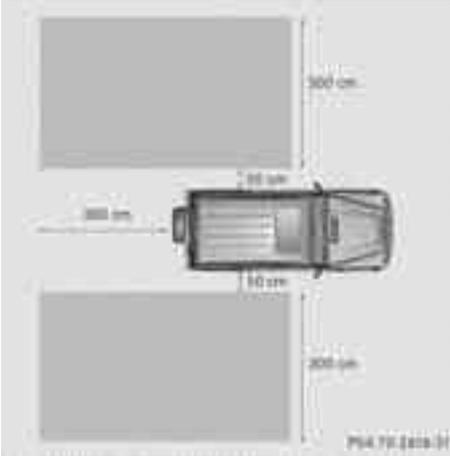

Blind Spot Assist monitors the area up to three metres behind your vehicle and directly next to your vehicle as shown in the diagram. If the lanes are narrow, vehicles driving in the lane beyond the lane next to your vehicle may be indicated, especially if the vehicles are not driving in the middle of their lane. This may be the case if the vehicles are driving on the inner side of their lane.

Due to the nature of the system:

- warnings may be issued in error when driving close to crash barriers or similar solid lane borders.
- warnings may be interrupted when driving alongside long vehicles, for example lorries, for a prolonged time.

The two sensors for Blind Spot Assist are integrated into the sides of the rear bumper. Make sure that the bumper is free of dirt, ice or slush in the vicinity of the sensors. The radar sensors must not be covered, for example by cycle racks or overhanging loads. Following a severe impact or in the event of damage to the bumpers, have the function of the radar sensors checked at a qualified specialist workshop. Blind Spot Assist may otherwise not work properly.

## Indicator and warning display

### WARNING

Blind Spot Assist does not react to:

- vehicles overtaken too closely on the side, placing them in the blind spot area
- vehicles approaching and driving by with a speed difference of more than approximately 11 km/h

As a result, Blind Spot Assist may not give warnings in such situations. There is a risk of an accident.

Always observe the traffic conditions carefully, and maintain a safe lateral distance.



### Yellow indicator lamp/red warning lamp

If Blind Spot Assist is switched on, indicator lamp  in the exterior mirrors lights up yellow up to a speed of 30 km/h. At speeds above 30 km/h, the indicator lamp goes out and Blind Spot Assist is operational.

If a vehicle is detected within the monitoring range of Blind Spot Assist at speeds above 30 km/h, warning lamp  on the corresponding side lights up red. This warning always occurs when a vehicle enters the blind spot monitoring range from behind or from the side. When you overtake a vehicle, the warning only occurs if the difference in speed is less than 12 km/h.

The yellow indicator lamp goes out if reverse gear is engaged. Blind Spot Assist is then deactivated.

The brightness of the indicator/warning lamps is adjusted automatically according to the ambient light.

### Collision warning

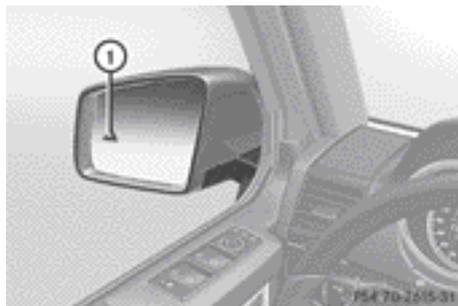

① Yellow indicator lamp/red warning lamp

If a vehicle is detected in the monitoring range of Blind Spot Assist and you switch on the corresponding turn signal, a double warning tone sounds. Red warning lamp ① flashes. If the turn signal remains on, detected vehicles are indicated by the flashing of red warning lamp ①. There are no further warning tones.

### Switching on Blind Spot Assist

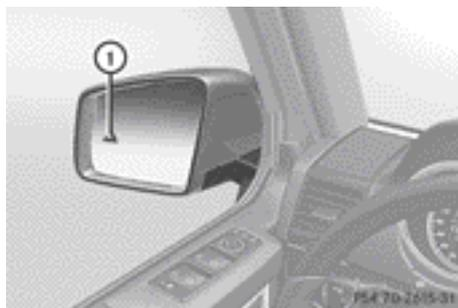

① Yellow indicator lamp/red warning lamp

► On vehicles without an integrated navigation system, make sure that the Becker®

MAP PILOT is connected; see the separate operating instructions for Audio 20.

- Make sure that Blind Spot Assist is activated in the on-board computer (▷ page 220).
- Turn the key to position **2** (▷ page 143) in the ignition lock. Warning lamps ① in the exterior mirrors light up red for approximately 1.5 seconds and then turn yellow.

### Towing a trailer

If you attach a trailer, make sure that you have correctly established the electrical connection. This can be accomplished by checking the trailer lighting. Blind Spot Assist is then deactivated. The indicator lamp lights up yellow in the exterior mirrors and the **Blind Spot Assist currently unavailable See Owner's Manual** message appears in the multifunction display.

❗ You can deactivate the indicator lamps in the exterior mirrors.

To do so, switch off Blind Spot Assist if:

- the key is in position **2** in the ignition lock.
- the engine is not running.
- the electrical connection to the trailer has been established.

### Active Blind Spot Assist

#### Important safety notes

#### ⚠ WARNING

Active Blind Spot Assist does not react to:

- vehicles overtaken too closely on the side, placing them in the blind spot area
- vehicles approaching and driving by with a speed difference of more than approximately 11 km/h

In such situations, Active Blind Spot Assist cannot warn you or intervene. There is a risk of an accident.

Always observe the traffic conditions carefully, and maintain a safe lateral distance.

Active Blind Spot Assist is only an aid. It may fail to detect some vehicles and is no substitute for attentive driving.

In particular, the detection of obstacles can be impaired if:

- there is dirt on the sensors or anything else covering the sensors.
- visibility is poor, e.g. due to fog, heavy rain or snow.
- there is a narrow vehicle travelling in front, e.g. a motorcycle or bicycle.
- the road has very wide lanes.
- the road has narrow lanes.
- you are not driving in the middle of the lane.
- there are barriers or other road boundaries.

### General notes

Active Blind Spot Assist uses a radar sensor system to monitor the side areas of your vehicle which are behind the driver. A warning display in the exterior mirrors draws your attention to vehicles detected in the monitored area. If you then switch on the corresponding turn signal to change lane, you will also receive an optical and audible collision warning. If a risk of lateral collision is detected, corrective braking may help you avoid a collision. To support the course-correcting brake application, Active Blind Spot Assist also uses the forward-facing radar sensor system.

Active Blind Spot Assist supports you from a speed of approximately 30 km/h.

### Monitoring range

#### WARNING

Active Blind Spot Assist monitors certain areas in the immediate vicinity of your vehicle.

Vehicles that approach and drive past at high speeds are not detected. No visual nor audible warnings are emitted and the system does not brake the vehicle to correct your course.

If the lanes are very wide, it may not be possible to monitor the complete width of the neighbouring lane. For this reason, vehicles in the next lane may not be detected, especially if they are driving in a staggered formation.

This may be the case if vehicles are driving at the edge of their lane that is furthest away from your vehicle.

Always pay attention to traffic conditions and your surroundings. Otherwise, you may fail to recognise dangers in time, cause an accident and injure yourself and others.

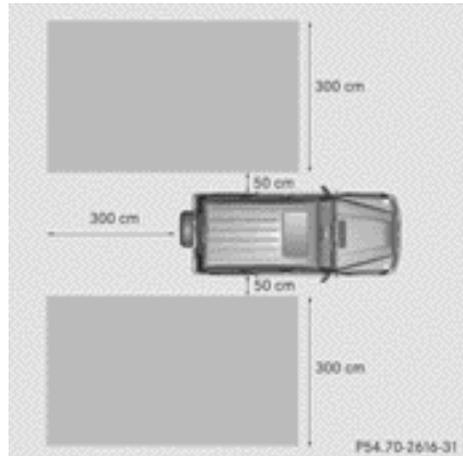

Active Blind Spot Assist monitors the area up to 3.0 m behind your vehicle and directly next to your vehicle, as shown in the diagram. For this purpose, Active Blind Spot Assist uses radar sensors in the rear bumper.

If the lanes are narrow, vehicles driving in the lane beyond the lane next to your vehicle may be indicated, especially if the vehicles are not driving in the middle of their lane. This may be the case if there are vehicles at the edge of their lane nearest your vehicle.

Due to the nature of the system:

- warnings may be issued in error when driving close to crash barriers or similar solid lane borders.
- warnings may be interrupted when driving alongside particularly long vehicles, for example lorries, for a prolonged time.

Two Active Blind Spot Assist radar sensors are integrated into the front and rear bumpers respectively. An additional radar sensor is located behind the cover in the radiator grille. Make sure that the bumpers and the cover in the radiator grille are free of dirt, ice or slush. The rear sensors must not be covered, e.g. by bicycle racks or overhanging loads. Following a severe impact or in the event of damage to the bumpers, have the function of the radar sensors checked at a qualified specialist workshop. Active Blind Spot Assist may otherwise no longer work properly.

### Indicator and warning display

#### WARNING

Active Blind Spot Assist is not active at speeds below 30 km/h. The indicator lamps in the exterior mirrors are yellow. Vehicles in the monitoring range are then not indicated.

Always pay attention to traffic conditions and your surroundings. Otherwise, you may fail to recognise dangers in time and cause an accident and injure yourself and others.

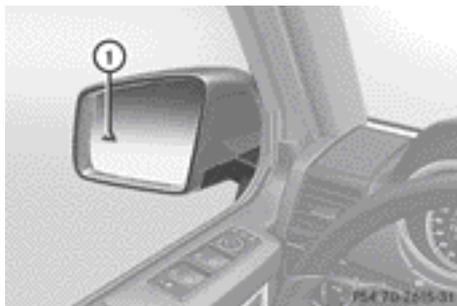

① Yellow indicator lamp/red warning lamp

When Active Blind Spot Assist is activated, indicator lamp ① in the exterior mirrors lights

up yellow at speeds of up to 30 km/h. At speeds above 30 km/h, the indicator lamp goes out and Active Blind Spot Assist is operational.

If a vehicle is detected within the monitoring range of Blind Spot Assist at speeds above 30 km/h, warning lamp ① on the corresponding side lights up red. This warning always occurs when a vehicle enters the blind spot monitoring range from behind or from the side. When you overtake a vehicle, the warning only occurs if the difference in speed is less than 12 km/h.

The yellow indicator lamp goes out if reverse gear is engaged. Active Blind Spot Assist is then no longer active.

The brightness of the indicator/warning lamps is adjusted automatically according to the ambient light.

### Visual and acoustic collision warning

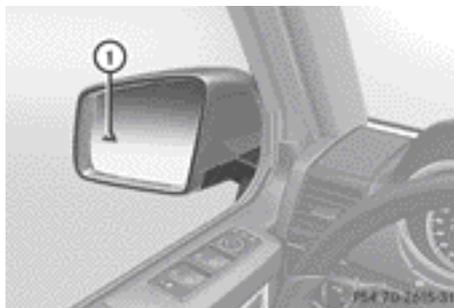

When you switch on the turn signals to change lanes and a vehicle is detected in the side monitoring range, you receive a visual and acoustic collision warning. You then hear a double warning tone and red warning lamp ① flashes. If the turn signal remains on, detected vehicles are indicated by the flashing of red warning lamp ①. There are no further warning tones.

## Course-correcting brake application

### WARNING

Active Blind Spot Assist is only an aid designed to assist driving. It is not a substitute for attentive driving. Automatic braking by the system may not always be sufficient to avoid a collision. In such cases, you need to steer, brake or accelerate yourself.

In very rare cases, the system may detect a risk of collision where there is none and brake in error near crash barriers or similar road boundaries. Active Blind Spot Assist cannot detect all traffic situations and road users. Ensure at all times that there is sufficient lateral distance between you and other road users or obstacles. You can, for example, countersteer gently or depress the accelerator pedal at any time to cancel inappropriate braking action.

You are responsible for the vehicle's speed, correct steering and for braking in good time. Always adapt your driving style to suit the prevailing road and weather conditions. Always pay attention to traffic conditions and your surroundings. Otherwise, you may fail to recognise dangers in time, cause an accident and injure yourself and others.

If a course-correcting brake application occurs, red warning lamp  flashes in the exterior mirror and a dual warning tone sounds. In addition, display  appears in the multifunction display.

If Active Blind Spot Assist detects a risk of a lateral collision in the monitoring range, a course-correcting brake application is carried out. This is designed to help you avoid a collision.

The course-correcting brake application is available in the range between 30 km/h and 200 km/h.

Either a very slight course-correcting brake application, or none at all, may occur if:

- there are vehicles or obstacles, e.g. crash barriers, on both sides of your vehicle.
- a vehicle approaches too closely on the side.
- you have adopted a sporty driving style with high cornering speeds.
- you brake or accelerate decisively.
- a driving safety system intervenes, e.g. ESP®.
- ESP® is deactivated.
- the LOW RANGE off-road gear is activated.
- a loss of tyre pressure has been detected.

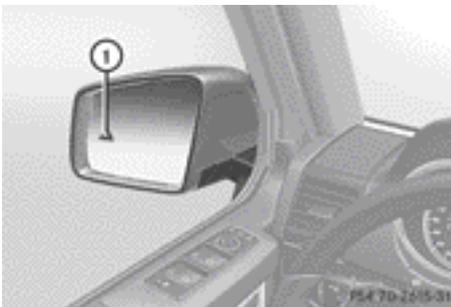

## Activating Active Blind Spot Assist

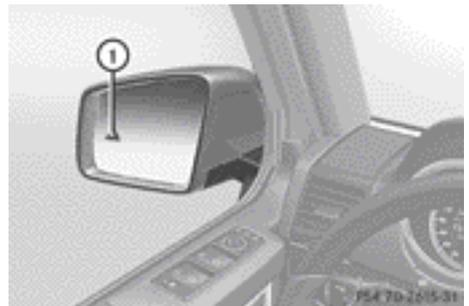

- ▶ Make sure that active Blind Spot Assist (▷ page 220) is activated in the on-board computer.
- ▶ Turn the key to position **2** in the ignition lock.  
Warning lamps ① in the exterior mirrors light up red for approximately 1.5 seconds and then turn yellow.

### Towing a trailer

If you attach a trailer, make sure that you have correctly established the electrical connection. This can be accomplished by checking the trailer lighting. Active Blind Spot Assist is then deactivated. The indicator lamp lights up yellow in the exterior mirrors and the **Active Blind Spot Assist currently unavailable See Owner's Manual** message appears in the multifunction display.

### HOLD function

#### General notes

The HOLD function can assist the driver in the following situations:

- when pulling away, especially on steep slopes
- when manoeuvring on steep slopes
- when waiting in traffic

The vehicle is kept stationary without the driver having to depress the brake pedal.

The braking effect is cancelled and the HOLD function is deactivated when you depress the accelerator pedal to pull away.

- ❗ Do not use the HOLD function when driving off-road, on steep uphill or downhill gradients or on slippery or loose surfaces. The HOLD function cannot hold the vehicle on such surfaces.

### Activation conditions

You can activate the HOLD function if:

- the vehicle is stationary.
- the engine is running or it has been switched off by the ECO start/stop function (AMG vehicles).
- the engine is running.
- the driver's door is closed or your seat belt is fastened.
- the transmission is in position **D**, **R** or **N**.
- DISTRONIC PLUS is deactivated.

### Activating the HOLD function

The vehicle's brakes are applied when the HOLD function is activated. For this reason, deactivate the HOLD function while in the car wash or while towing.

- ▶ Make sure that the activation conditions are met.
- ▶ Depress the brake pedal.
- ▶ Quickly depress the brake pedal further until **HOLD** appears in the multifunction display.  
The HOLD function is activated. You can release the brake pedal.

- ❗ If depressing the brake pedal the first time does not activate the HOLD function, wait briefly and then try again.

### Deactivating the HOLD function

#### WARNING

When leaving the vehicle, it can still roll away despite being braked by the HOLD function if:

- there is a malfunction in the system or in the voltage supply
- the HOLD function is deactivated by the accelerator pedal being depressed, e.g. by a vehicle occupant
- the electrical system in the engine compartment, the battery or the fuses are tampered with
- the battery is disconnected

There is a risk of an accident.

Before leaving the vehicle, always deactivate the HOLD function and secure the vehicle from rolling away.

The HOLD function is deactivated automatically if:

- you accelerate and the transmission is in position **D** or **R**.
- you shift the transmission to position **P**.
- you depress the brake pedal again with a certain amount of pressure until **HOLD** disappears from the multifunction display.
- you activate DISTRONIC PLUS.

On steep uphill or downhill gradients or if there is a malfunction, the transmission may also be automatically shifted into position **P**.

#### 4MATIC (permanent all-wheel drive)

**!** Never tow the vehicle with one axle raised. This may damage the transfer case. Damage of this sort is not covered by the Mercedes-Benz implied warranty. All wheels must remain either on the ground or be fully raised. Observe the instructions for towing the vehicle with all wheels in full contact with the ground.

**!** When testing the parking brake, operate the vehicle only briefly (for a maximum of ten seconds) on a brake test dynamometer. When doing this, turn the key to position **0** or **1** in the ignition. Failure to do this can cause damage to the drive train or the brake system.

**!** A function or performance test should only be carried out on a twin-axle dynamometer. Before you operate the vehicle on such a dynamometer, please consult a qualified workshop. You could otherwise damage the drive train or the brake system.

4MATIC ensures that all four wheels are permanently driven. Together with ESP® and 4ETS, it improves the traction of your vehicle

whenever a drive wheel spins due to insufficient grip.

If a drive wheel spins due to insufficient grip:

- when pulling away, only depress the accelerator pedal as far as is necessary.
- accelerate less when driving.

If you fail to adapt your driving style, 4MATIC can neither reduce the risk of accident nor override the laws of physics. 4MATIC cannot take account of road, weather and traffic conditions. 4MATIC is only an aid. You are responsible for the distance to the vehicle in front, for vehicle speed, for braking in good time and for staying in lane. Only engage 4MATIC when the current road, weather and traffic conditions permit it to be done safely, and adapt your driving style accordingly. Drive carefully and maintain a suitable distance to the vehicle in front.

**i** In wintry driving conditions, the maximum effect of 4MATIC can only be achieved if you use winter tyres (M+S tyres), with snow chains if necessary.

For information about driving off-road, see (▷ page 169).

#### PARKTRONIC

##### Important safety notes

**!** When parking, pay particular attention to objects above or below the sensors, such as flower pots or trailer drawbars. PARKTRONIC does not detect such objects when they are in the immediate vicinity of the vehicle. You could damage the vehicle or the objects.

The sensors may not detect snow and objects which absorb ultrasonic sources. Ultrasonic sources, such as an automatic car wash, a lorry's compressed-air brakes or a pneumatic drill, could cause PARKTRONIC to malfunction.

PARKTRONIC may not function correctly on uneven terrain.

PARKTRONIC is an electronic parking aid with ultrasonic sensors. It indicates visually and audibly the distance between your vehicle and an object.

PARKTRONIC is only an aid. It is not a replacement for your attention to your immediate surroundings. You are always responsible for safe manoeuvring, parking and exiting a parking space. Check in front, behind and to the sides of the vehicle before manoeuvring, parking or exiting a parking space. There must not be any persons, animals or objects in the area in which you are manoeuvring.

PARKTRONIC cannot identify any persons or objects outside of the detection range. As a result, PARKTRONIC cannot warn you about objects in this area.

PARKTRONIC is activated automatically if you:

- switch on the ignition
- shift the transmission to position **D**, **R** or **N**
- release the parking brake

PARKTRONIC is deactivated at speeds above 18 km/h. It is reactivated at lower speeds.

PARKTRONIC monitors the area around your vehicle using six sensors in the front bumper and four sensors in the rear bumper.

## Range of the sensors

### General notes



- ① Example: sensors in the front bumper, left-hand side



Side view

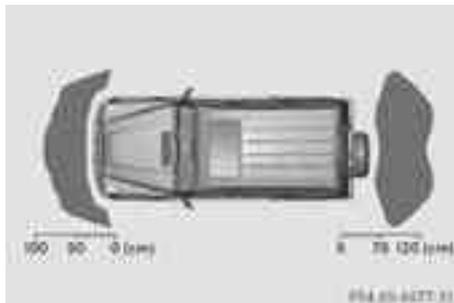

Top view

The sensors must be free of dirt, ice and slush. Otherwise, they may not function correctly. Clean the sensors regularly, taking care not to scratch or damage them (▷ page 294).

### Front sensors

Centre	Approximately 100 cm
Corners	Approximately 60 cm

### Rear sensors

Centre	Approximately 90 cm (from spare wheel)
Corners	Approximately 80 cm

### Minimum distance

Centre	Approximately 20 cm
Corners	Approximately 20 cm

If there is an obstacle within this range, the relevant warning displays light up and a warning tone sounds. If the distance falls below the minimum, the distance may no longer be shown.

## Warning displays

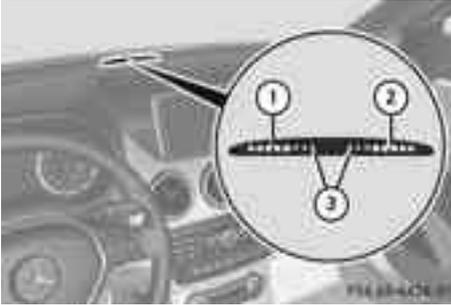

Warning display for the front area

- ① Segments on the left-hand side of the vehicle
- ② Segments on the right-hand side of the vehicle
- ③ Segments showing operational readiness

The warning displays show the distance between the sensors and the obstacle. The warning display for the front area is located on the dashboard above the centre air vents. The warning display for the rear area is located on the roof lining in the rear compartment.

The warning display for each side of the vehicle is divided into five yellow and two red segments. PARKTRONIC is operational if yellow segments showing operational readiness ③ light up.

The selected transmission position and the direction in which the vehicle is rolling determine which warning display is active when the engine is running.

Transmission position	Warning display
D	Front area activated
R, N or the vehicle is rolling backwards	Rear and front areas activated
P	No areas activated

One or more segments light up as the vehicle approaches an obstacle, depending on the vehicle's distance from the obstacle.

From the:

- sixth segment onwards, you will hear an intermittent warning tone for approximately two seconds.
- seventh segment onwards, you will hear a warning tone for approximately two seconds. This indicates that you have now reached the minimum distance.

## Deactivating/activating PARKTRONIC



- ① Indicator lamp
- ② To deactivate/activate PARKTRONIC

If indicator lamp ① lights up, PARKTRONIC is deactivated.

- ❗ PARKTRONIC is automatically activated when you turn the key to position 2 in the ignition lock.

## Towing a trailer

PARKTRONIC is deactivated for the rear area when you establish an electrical connection between your vehicle and a trailer.

## Problems with PARKTRONIC

Problem	Possible causes/consequences and ► Solutions
<p>Only the red segments in the PARKTRONIC warning displays are lit. You also hear a warning tone for approximately two seconds.</p> <p>PARKTRONIC is deactivated after a few seconds, and the indicator lamp in the PARKTRONIC button lights up.</p>	<p>PARKTRONIC has malfunctioned and has switched off.</p> <p>► If problems persist, have PARKTRONIC checked at a qualified specialist workshop.</p>
<p>Only the red segments in the PARKTRONIC warning displays are lit. PARKTRONIC is deactivated after a few seconds.</p>	<p>The PARKTRONIC sensors are dirty or there is interference.</p> <p>► Clean the PARKTRONIC sensors (► page 294).</p> <p>► Switch the ignition back on.</p>
	<p>The problem may be caused by an external source of radio or ultrasound waves.</p> <p>► See if PARKTRONIC functions in a different location.</p>

## Reversing camera

### Important safety notes

The reversing camera is only an aid. It is not a replacement for your attention to your immediate surroundings. You are always responsible for safe manoeuvring and parking. When manoeuvring or parking, make sure that there are no persons, animals or objects in the area in which you are manoeuvring.

Under the following circumstances, the reversing camera will not function, or will function in a limited manner:

- the rear door is open
- in heavy rain, snow or fog
- at night or in very dark places
- if the camera is exposed to very bright light
- if the area is lit by fluorescent light or LED lighting (the display may flicker)

- if there is a sudden change in temperature, e.g. when driving into a heated garage in winter
- if the camera lens is dirty or obstructed
- if the rear of your vehicle is damaged. In this event, have the camera position and setting checked at a qualified specialist workshop. Mercedes-Benz recommends that you use a Mercedes-Benz Service Centre for this purpose.

## Activating/deactivating the reversing camera



① Reversing camera



- ▶ **To activate:** make sure that the key is in position **2** in the ignition lock.
- ▶ Make sure that the "Reversing camera" function is selected in COMAND Online; see the separate operating instructions for COMAND Online.
- ▶ Engage reverse gear.  
The area behind the vehicle is shown with guide lines in the COMAND display.
- ▶ **To change the function mode:** using the COMAND controller, select symbol **①** for the "Reverse parking" function or symbol **②** for "Coupling up a trailer" (see the separate COMAND Online operating instructions).  
The symbol of the selected function is highlighted.

**To deactivate:** the reversing camera is deactivated if you:

- shift the transmission to position **P**
- drive forward ten metres
- shift the transmission from **R** to another position (after 15 seconds)
- drive forwards at a speed of over 10 km/h

## Off-road driving systems

### Transfer case

#### General notes

The vehicle has permanent all-wheel drive. The front and rear axles are constantly driven. For further information on driving off-road, see (▷ page 169).

#### Shift ranges

#### **WARNING**

If you do not wait for the transfer case gear change process to complete, the transfer case could remain in the neutral position. The power transmission to the driven wheels is then interrupted. There is a danger of the vehicle rolling away unintentionally. There is a risk of an accident.

Wait until the transfer case shift process is completed.

Do not turn off the engine while changing gear and do not shift the automatic transmission to another gear.

<b>HIGH RANGE</b>	Position for all normal on-road driving conditions
<b>LOW RANGE</b>	Low-range position for driving off-road Also for use on steep uphill or downhill gradients, especially when towing a trailer The vehicle travels around half the speed of on-road driving range <b>HIGH RANGE</b> . The tractive power is correspondingly higher.

### Shifting the transfer case

#### Important safety notes

##### **WARNING**

When the transfer case is in the neutral position, power transmission to the driven wheels is interrupted. As a result, the vehicle could roll away. There is a risk of an accident.

Secure the vehicle with the parking brake, and on uphill or downhill gradients, also secure it with a device such as a wheel chock.

##### **WARNING**

When the transfer case is in the neutral position, power transmission to the driven wheels is interrupted. As a result, the vehicle could roll away. There is a risk of an accident.

Secure the vehicle with the parking brake, and on uphill or downhill gradients, also secure it with a device such as a wheel chock.

Always wait for the gear change process from **HIGH RANGE** to **LOW RANGE** and from **LOW RANGE** to **HIGH RANGE** to complete. Do not turn off the engine while changing gear and do not shift the automatic transmission to another gear.

#### General notes



① Current shift range



① Indicator lamp

② LOW RANGE button

#### Switching on the off-road gear ratio

**!** Only carry out the gear selection if:

- the engine is running.
- the vehicle is rolling.
- the automatic transmission is in selector lever position **N**.
- you are driving at less than 40 km/h.

You could otherwise damage the transfer case.



**i** **AMG vehicles:** to shift the transfer case to **LOW RANGE**, deactivate the ECO start/stop function (▷ page 146).

- ▶ Press LOW RANGE button ②.  
When the shift procedure is complete, the **LOW RANGE** transfer case position appears in the multifunction display.  
Indicator lamp ① lights up.
- ▶ Shift the transmission to position **D**.

### Switching off the off-road gear ratio

#### **WARNING**

When the transfer case is in the neutral position, power transmission to the driven wheels is interrupted. As a result, the vehicle could roll away. There is a risk of an accident.

Secure the vehicle with the parking brake, and on uphill or downhill gradients, also secure it with a device such as a wheel chock.

- ❗ Only carry out the gear selection if:
  - the engine is running.
  - the vehicle is rolling.
  - the automatic transmission is in selector lever position **N**.
  - you are driving at less than 70 km/h.
 You could otherwise damage the transfer case.

- ▶ Press button ②.  
When the shift procedure is complete, the **HIGH RANGE** transfer case position appears in the multifunction display.  
Indicator lamp ① goes out.

If the gear change is not completed, the following messages could appear in the display:

- **TC shift conditions not fulfilled**  
You have not met one or more shift conditions.
- **TC NEUTRAL on**  
The transfer case has cancelled the gear change process and is in **N**. The **N** transfer case position appears in the multifunction display.
- **TC shift cancelled**  
The transfer case has not performed the gear change process.

- ▶ Repeat the gear change process.  
Make sure to meet all conditions for changing gears.
  - **TC Malfunction Visit workshop**  
There is a malfunction in the transfer case.
- ▶ Do not shift the transfer case.
- ▶ Have the vehicle checked as soon as possible at a qualified specialist workshop.

### Shifting to neutral

#### **WARNING**

When the transfer case is in the neutral position, power transmission to the driven wheels is interrupted. As a result, the vehicle could roll away. There is a risk of an accident.

Secure the vehicle with the parking brake, and on uphill or downhill gradients, also secure it with a device such as a wheel chock.

- ▶ Turn the key to position **2** (▷ page 143) in the ignition lock.
- ▶ Apply the parking brake.
- ▶ Depress the brake pedal.
- ▶ Move the selector lever to position **N** (▷ page 149).
- ▶ Press and hold LOW RANGE button ② for approximately 10 seconds.  
Once the gear change procedure is complete, **TC in neutral** message appears in the multifunction display for approximately 5 seconds.

If the gear change is not completed, the following messages could appear in the display (▷ page 241).

- ❗ If the transfer case is in **Neutral**, the key is in the ignition lock and you open the driver's door, the **TC in neutral** message appears in the multifunction display. If you then release the parking brake, a warning tone will sound.

## Differential lock

### General notes

#### WARNING

When differential locks are engaged on a firm, high-grip surface, the vehicle's steerability is greatly impaired. In particular, engaging the differential locks when cornering could lead to you losing control of the vehicle. There is a risk of an accident.

Disengage the differential locks immediately on firm, high-grip surfaces.

**!** To prevent damage in the transfer case, you may only operate the vehicle on a roller dynamometer (single-axle roller dynamometer) if:

- the axle that is not being driven is raised.  
or
- the corresponding propeller shaft is disconnected and the transfer case differential lock is activated.

Otherwise, the transfer case can be damaged.

Differential locks improve the traction of the vehicle.

Your vehicle is equipped with a differential lock for:

- the transfer case: this controls the balance between the front and rear axles.
- the rear axle: this controls the balance between the wheels on the rear axle.
- the front axle: this controls the balance between the wheels on the front axle.

### Activating the differential lock

#### Important safety notes

#### WARNING

When differential locks are engaged on a firm, high-grip surface, the vehicle's steerability is greatly impaired. In particular, engaging the differential locks when cornering could lead

to you losing control of the vehicle. There is a risk of an accident.

Disengage the differential locks immediately on firm, high-grip surfaces.

#### WARNING

ABS, 4ETS, ESP® and BAS are deactivated while the differential locks are engaged. As a result, the wheels could lock when braking and the braking distance is increased. There is a risk of an accident.

Disengage the differential locks immediately on firm, high-grip surfaces.

**!** Only activate the differential locks when:

- you are driving at walking pace.
- the driven wheels are not spinning.
- you are not driving on a firm road surface.

### General notes

The switches are located on the centre console.

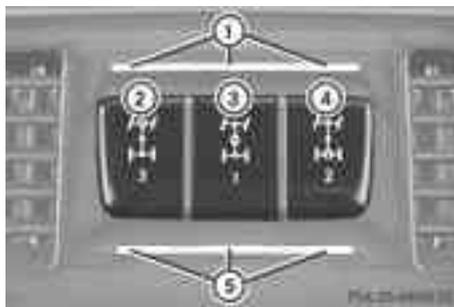

- ① Function indicator lamps (red)
- ② Differential lock for the front axle
- ③ Differential lock for the transfer case
- ④ Differential lock for the rear axle
- ⑤ Activation indicator lamps (yellow)

Activate the differential locks:

- off-road
- to deactivate ABS, 4ETS, ESP® and BAS when off-road
- when fording

For further information on driving off-road, see (▷ page 169).

- i** You can only engage the differential locks if the transfer case is in the **LOW RANGE** off-road driving position (▷ page 201).
- i** You can activate the differential locks in the following order (3), (4), (2).

### Differential lock for the transfer case

- ▶ **To engage:** switch the transfer case to the **LOW RANGE** off-road driving position (▷ page 202).
- ▶ Press switch (3).

When the transfer case is in the **LOW RANGE** off-road driving position, the yellow activation indicator lamp below switch (3) lights up.

The  warning lamp in the instrument panel lights up.

When the differential is locked, the red function indicator lamp above switch (3) lights up.

The following message appears in the multifunction display:

**ABS not available differential locked**

The , ,  warning lamps in the instrument cluster light up.

The differential lock for the transfer case is engaged.

4ETS, ESP®, BAS and ABS are deactivated.

The vehicle's ability to steer is severely restricted. Drive carefully and accelerate gently for optimum traction.

- i** You can now engage the differential lock for rear axle (4) and the differential lock for front axle (2) as required.

### Differential lock for the rear axle

- ▶ **To engage:** press switch (4).
- Yellow activation indicator lamp (5) lights up first, followed by red function indicator lamp (1) of switch (4).
- The differential lock for the rear axle is engaged.

### Differential lock for the front axle

- ▶ **To engage:** press switch (2).
- The yellow activation indicator lamp lights up first, followed by the red function indicator lamp.
- The differential lock for the front axle is engaged.

### Deactivating the differential lock

You can deactivate the differential locks in this order: (2), (4), (3).

- ▶ **To simultaneously deactivate all differential locks:** press switch (3).

Yellow activation indicator lamps (5) and red function indicator lamps (1) go out.

After approximately three seconds of normal driving, ABS, 4ETS, ESP® and BAS are activated.

The **ABS not available differential locked** message disappears from the multifunction display and the ,  and  warning lamps in the instrument cluster go out.

- ▶ Shift the transfer case to the **HIGH RANGE** on-road position (▷ page 202).

If red function indicator lamps (1) do not go out when deactivating the differential locks:

- ▶ Observe the traffic situation.
  - ▶ While driving, make some gentle steering movements.
- Red function indicator lamps (1) go out as soon as the differential locks have been disengaged.

## Towing a trailer

### Notes on towing a trailer

#### Important safety notes

##### WARNING

The braking system can overheat if you leave your foot on the brake pedal while driving. This increases the braking distance and could even cause the braking system to fail. There is a risk of an accident.

Never use the brake pedal as a footrest. Do not simultaneously depress both the brake pedal and the accelerator pedal while driving.

##### WARNING

You could lose control of the vehicle/trailer combination if it begins to swerve. The vehicle/trailer combination could even overturn. There is a risk of an accident.

On no account should you attempt to straighten out the vehicle/trailer combination by increasing speed. Decrease your speed and do not countersteer. Brake if necessary.

##### WARNING

If the ball coupling has not been correctly fitted and has not been secured with the bolt supplied and the corresponding spring cotter, the trailer can detach. There is a risk of an accident.

Always fit and secure the ball coupling as described. Before beginning each journey, make sure that the fitted ball coupling is secured with the bolt supplied and the corresponding spring cotter.

You will find the applicable permissible values, which must not be exceeded, in the vehicle documents. You will find the values approved by the manufacturer on the vehicle identification plates and those for the towing vehicle in the "Technical data" section (▷ page 336).

Couple and uncouple the trailer carefully. If you do not couple the trailer to the towing vehicle correctly, the trailer could become detached.

Make sure that the following values are not exceeded:

- the permissible trailer drawbar noseweight
- the permissible trailer load
- the permissible rear axle load of the towing vehicle
- the maximum permissible gross vehicle weight of both the towing vehicle and the trailer

When towing a trailer, your vehicle's handling characteristics will be different in comparison to when driving without a trailer.

The vehicle/trailer combination:

- is heavier
- is restricted in its acceleration and gradient-climbing capability
- has an increased braking distance
- is affected more by strong crosswinds
- demands more sensitive steering
- has a larger turning circle

This can impair the vehicle's handling characteristics.

When towing a trailer, always adjust your speed to the current road and weather conditions. Do not exceed the maximum permissible speed for your vehicle/trailer combination.

#### General notes

 Use a drawbar noseweight as close to the maximum permissible noseweight as possible. Do not use a noseweight of less than 80 kg; otherwise, the trailer may come loose.

Note that the payload and the rear axle load are reduced by the actual payload.

 When towing a trailer, set the tyre pressure on the rear axle of the towing vehicle

for a maximum load; see the tyre pressure table in the fuel filler flap (▷ page 321).

You will find installation dimensions and loads in the technical data (▷ page 346).

The maximum permissible trailer drawbar noseweight on the ball coupling is:

- 140 kg (G-Class long-wheelbase version)
- 115 kg (G-Class Cabriolet)

However, the actual noseweight must not exceed the value given on the trailer tow hitch or trailer identification plates. The lowest weight applies.

- i** When towing a trailer, set the tyre pressure on the rear axle of the towing vehicle for a maximum load; see the tyre pressure table in the fuel filler flap (▷ page 321).

Please note that when towing a trailer, PARKTRONIC (▷ page 197) and Blind Spot Assist (▷ page 190) are only available with limitations, or not at all.

- i** On vehicles without level control, the height of the ball coupling will alter according to the load placed on the vehicle. If necessary, use a trailer with a height-adjustable drawbar.

### Driving tips

- ▶ On long and steep downhill gradients, select shift range **1**, **2** or **3** (▷ page 153) in good time.

- i** This also applies if you have activated cruise control or SPEEDTRONIC.

- ▶ If necessary, shift the transfer case to **LOW RANGE** (▷ page 202).

This will use the braking effect of the engine, so less braking will be required to prevent the vehicle from gaining speed. This relieves the load on the brake system and prevents the brakes from overheating and wearing too quickly. If you need additional braking, depress the brake pedal repeatedly rather than continuously.

The maximum permissible speed for vehicle/trailer combinations depends on the type of trailer. Before beginning the journey, check the trailer's documents to see what the maximum permitted speed is. Observe the legally prescribed maximum speed in the relevant country.

For certain Mercedes-Benz vehicles, the maximum permissible rear axle load is increased when towing a trailer. Refer to the "Technical data" section to find out whether this applies to your vehicle. If you utilise any of the added maximum rear axle load when towing a trailer, the vehicle/trailer combination may not exceed a maximum speed of 100 km/h for reasons concerning the operating permit. This also applies in countries in which the permissible maximum speed for vehicle/trailer combinations is above 100 km/h.

When towing a trailer, your vehicle's handling characteristics will be different in comparison to when driving without a trailer, and it will consume more fuel.

### Driving tips

If the trailer swings from side to side:

- ▶ Do not accelerate.
- ▶ Do not countersteer.
- ▶ Brake if necessary.
- Maintain a greater distance from the vehicle in front than when driving without a trailer.
- Avoid braking abruptly. If possible, brake gently at first to allow the trailer to run on. Then, increase the braking force rapidly.
- The values given for gradient-climbing capabilities from a standstill refer to sea level. When driving in mountainous areas, note that the power output of the engine, and consequently the vehicle's gradient-climbing capability, decrease with increasing altitude.

### Trailer power supply

**!** You can connect accessories with a maximum power consumption of 180 W to the permanent power supply.

You must not charge a trailer battery using the power supply.

The trailer socket of your vehicle is equipped at the factory with a permanent power supply.

The permanent power supply is supplied via trailer socket pin 9.

You can find more information about fitting the trailer electrics at a qualified specialist workshop.

- ▶ Let the cover engage.
- ▶ If you are using an adapter cable, secure the cable to the trailer with cable ties.

**i** When the socket is connected, the ultrasonic reversing aid is deactivated.

### Trailer with 7-pin connector

#### General notes

You can make a connection to the 13-pin socket on the ball coupling using an adapter or, if necessary, an adapter cable. Both can be obtained at a qualified specialist workshop.

#### Fitting the adapter

**!** Make sure that there is sufficient cable play so that the cable cannot become detached when cornering.



- ▶ Open the socket cover.
- ▶ Insert the connector with lug ① into groove ② on the socket and turn the connector clockwise to the stop.

Useful information .....	210
Important safety notes .....	210
Displays and operation .....	211
Menus and submenus .....	214
Display messages .....	228
Warning and indicator lamps in the instrument cluster .....	251

## Useful information

- i** This Owner's Manual describes all models, series and optional equipment for your vehicle that were available at the time of going to press. Country-specific differences are possible. Note that your vehicle may not be fitted with all features described. This is also the case for systems and functions relevant to safety.
- i** Read the information on qualified specialist workshops: (▷ page 22).

## Important safety notes

 **WARNING**

Only use the on-board computer when road and traffic conditions permit. You would otherwise be distracted and unable to concentrate properly on driving, and could cause an accident.

 **WARNING**

No messages will be displayed if either the instrument cluster or the multifunction display is inoperative.

As a result, you will not be able to see information about your driving conditions, such as speed, outside temperature, warning and indicator lamps, display messages or system failures. Driving characteristics may be impaired. Adjust your driving style and vehicle speed accordingly.

Contact a qualified specialist workshop immediately.

 **WARNING**

The on-board computer only records and displays malfunctions and warnings from certain systems. For this reason, you should always make sure that your vehicle is safe to use. You could otherwise cause an accident by driving an unsafe vehicle.

 **WARNING**

The operating safety of your vehicle could be impaired if maintenance work is carried out incorrectly. This could cause you to lose control of your vehicle and cause an accident. Moreover, the safety systems may no longer be able to protect you or others as they are designed to do.

Always have service work carried out at a qualified specialist workshop.

For an illustration of the instrument cluster, see (▷ page 211).

## Displays and operation

## Instrument cluster

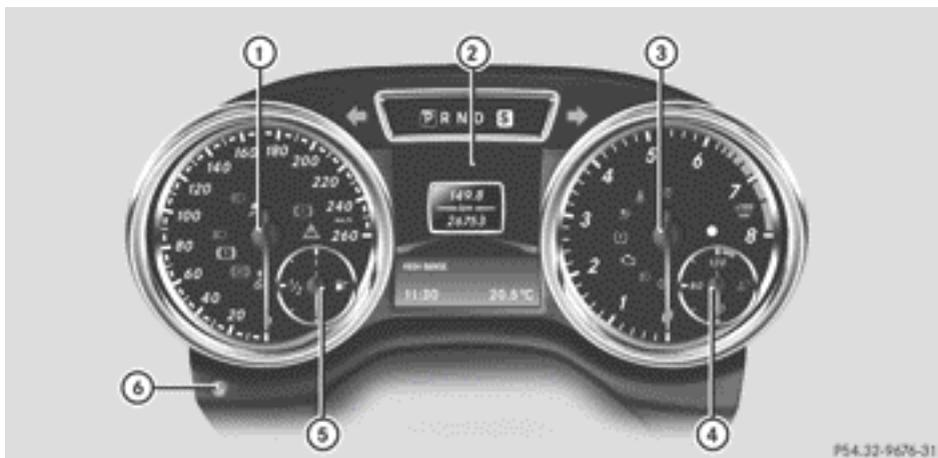

Instrument cluster: kilometres

- ① Speedometer with segments (▷ page 212)
- ② Multifunction display (▷ page 214)
- ③ Rev counter (▷ page 212)
- ④ Coolant temperature (▷ page 212)
- ⑤ Fuel gauge
- ⑥ Instrument cluster lighting (▷ page 212)

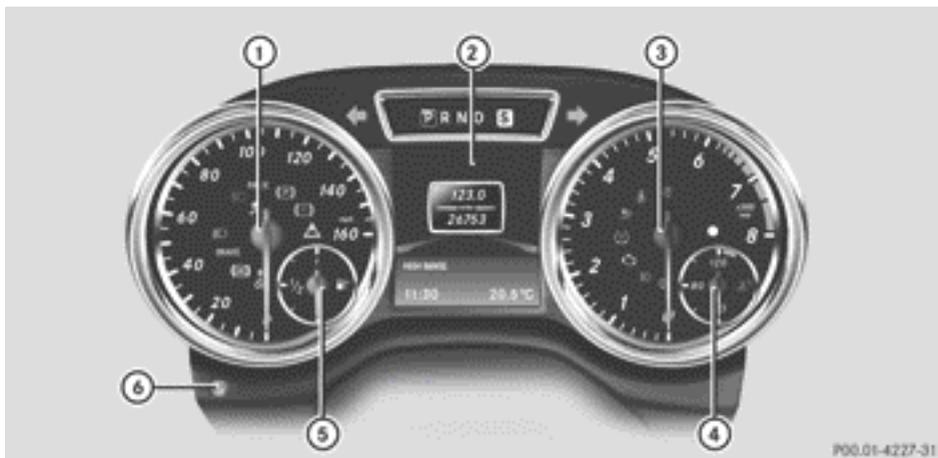

Instrument cluster: miles

- ① Speedometer with segments (▷ page 212)
- ② Multifunction display (▷ page 214)

- ③ Rev counter (▷ page 212)
- ④ Coolant temperature (▷ page 212)
- ⑤ Fuel gauge
- ⑥ Instrument cluster lighting (▷ page 212)

### Instrument cluster lighting

The lighting in the instrument cluster, in the displays and the controls in the vehicle interior can be adjusted using the brightness control knob.

The brightness control knob is located on the bottom left of the instrument cluster (▷ page 211).

- ▶ Turn the brightness control knob clockwise or anti-clockwise.

If the light switch is set to **AUTO**, **200%** or , the brightness is dependent upon the brightness of the ambient light.

- i** The light sensor in the instrument cluster automatically controls the brightness of the multifunction display.

In daylight, the displays in the instrument cluster are not illuminated.

### Displaying the coolant temperature

The coolant temperature gauge is in the instrument cluster on the right-hand side (▷ page 211).

The reading may rise up to 120 °C under normal driving conditions if the coolant has been filled correctly.

At high outside temperatures and when driving uphill, the coolant temperature may rise to the end of the scale.

### Rev counter

- !** Do not drive in the overrevving range. Doing so will damage the engine.

The red band in the rev counter indicates the engine's overrevving range.

The fuel supply is interrupted to protect the engine when the red band is reached.

### Outside temperature display

#### WARNING

At temperatures just above freezing point, the street may be icy, especially in wooded areas or on bridges. If you do not adapt your driving style to the conditions, the vehicle could skid. For this reason, adapt your driving style and speed to the weather conditions.

The outside temperature display is in the multifunction display (▷ page 214).

Changes in the outside temperature are displayed after a short delay.

### Speedometer with segments

The segments in the speedometer indicate which speed range is available.

- Cruise control activated (▷ page 173):  
The segments light up from the stored speed to the maximum speed.
- Variable SPEEDTRONIC activated (▷ page 178):  
The segments light up from the start of the scale to the selected limit speed.
- DISTRONIC PLUS activated (▷ page 184):  
One or two segments in the set speed range light up.
- DISTRONIC PLUS detects a vehicle in front:  
The segments between the speed of the vehicle in front and the stored speed light up.

## Operating the on-board computer

### Overview



- ① Multifunction display
- ② To switch on LINGUATRONIC, see the separate operating instructions
- ③ Right control panel
- ④ Left control panel
- ⑤ Back button

► **To activate the on-board computer:** turn the key to position **1** (► page 143) in the ignition lock.

You can control the multifunction display and the settings in the on-board computer using the buttons on the multifunction steering wheel.

### Left control panel

	• Calls up the menu and menu bar
	
	<b>Press briefly:</b>
	<ul style="list-style-type: none"> <li>• Scrolls through lists</li> <li>• Selects a submenu or function</li> <li>• In the <b>Audio</b> menu: selects a stored station, an audio track or a video scene</li> <li>• In the <b>Te1</b> (telephone) menu: switches to the phone book and selects a name or telephone number</li> </ul>
	<b>Press and hold:</b>
	<ul style="list-style-type: none"> <li>• In the <b>Audio</b> menu: selects the previous/next station or selects an audio track or a video scene using rapid scrolling</li> <li>• In the <b>Te1</b> (Telephone) menu: starts rapid scrolling if the phone book is open</li> </ul>
	<ul style="list-style-type: none"> <li>• Confirms selection/display message</li> <li>• In the <b>Te1</b> (telephone) menu: switches to the telephone book and starts dialling the selected number</li> <li>• In the <b>Audio</b> menu: stops the station search function at the desired station</li> </ul>

### Right control panel

	<ul style="list-style-type: none"> <li>• Rejects or ends a call</li> <li>• Exits telephone book/redial memory</li> </ul>
	<ul style="list-style-type: none"> <li>• Makes or accepts a call</li> <li>• Switches to the redial memory</li> </ul>



- Adjusts the volume



- Mute

### Back button



#### Press briefly:

- Back
- Switches off LINGUATRONIC, see the separate operating instructions
- Hides display messages/calls up the last **Trip** menu function used
- Exits the telephone book/redial memory



#### Press and hold:

- Calls up the standard display in the **Trip** menu

### Multifunction display



- ① Transmission position (▷ page 151)
- ② Drive program (▷ page 152)
- ③ Description field
- ④ Menu bar

- ⑤ Outside temperature or speed (▷ page 221)
- ⑥ Time
- ⑦ Transfer case position (▷ page 201)

► **To show menu bar** ④: press the ◀ or ▶ button on the steering wheel.

Menu bar ④ disappears after a few seconds.

Text field ③ shows the selected menu or submenu as well as display messages.

For further information on displaying the transmission position, see (▷ page 150).

**i** You can set the time using the audio system or COMAND APS, see the separate operating instructions.

The following messages can appear in the multifunction display:

↑ Upshift indicator (▷ page 154)



Cruise control (▷ page 173)

**LIM**

SPEEDTRONIC (▷ page 178)

**ECO**

ECO start/stop function (AMG vehicles) (▷ page 145)

**LOW**

**RANGE**

LOW RANGE off-road gear (▷ page 202)

**HOLD**

HOLD function (▷ page 196)

## Menus and submenus

### Menu overview

Press the ◀ or ▶ button on the steering wheel to call up the menu bar and select a menu.

Operating the on-board computer (▷ page 213).

Depending on the equipment fitted in the vehicle, you can call up the following menus:

- **Trip** menu (▷ page 215)
- **Navi** menu (navigation details) (▷ page 216)
- **Audio** menu (▷ page 217)
- **Te1** menu (telephone) (▷ page 218)
- **Assist.** menu (assistance) (▷ page 220)

- **Service** menu (▷ page 220)
- **Settings** menu (▷ page 221)
- **AMG** menu in AMG vehicles (▷ page 225)

The **Audio**, **Navi** and **TeI** menus differ slightly in vehicles with an audio system and in vehicles with COMAND Online. The examples given in this Owner's Manual apply to vehicles equipped with COMAND Online.

## Trip menu

### Standard display



- ▶ Press and hold the  button on the steering wheel until the **Trip** menu with trip meter ① and total distance recorder ② is shown.

### Trip computer "From start" or "From reset"



Example: "From start" trip computer

- ① Distance
  - ② Time
  - ③ Average speed
  - ④ Average fuel consumption
- ▶ Press the  or  button on the steering wheel to select the **Trip** menu.
  - ▶ Press  or  to select **From start** or **From reset**.

The values in the **From start** submenu are calculated from the start of a journey whilst the values in the **From reset** submenu are calculated from the last time the submenu was reset (▷ page 216).

The **From start** trip computer is automatically reset when:

- the ignition has been switched off for more than four hours.
- 999 hours have been exceeded.
- 9,999 kilometres have been exceeded.

The **From reset** trip computer is automatically reset if the value exceeds 9,999 hours or 99,999 kilometres.

### Displaying the range and current fuel consumption



- ① Approximate range
- ② Current fuel consumption (not for AMG vehicles)

- ▶ Press the  or  button on the steering wheel to select the **Trip** menu.
- ▶ Press the  or  button to select the current fuel consumption (not for AMG vehicles) and the approximate range.

The approximate range which can be covered depends on the fuel level and your current driving style. If there is only a small amount of fuel left in the fuel tank, the display shows a vehicle being refuelled  instead of range.

## Digital speedometer



### ① Digital speedometer

- ▶ Press the  or  button on the steering wheel to select the **Trip** menu.
- ▶ Press the  or  button to select the digital speedometer.

## Resetting values



Example: resetting the trip computer "From start"

- ▶ Press the  or  button on the steering wheel to select the **Trip** menu.
- ▶ Press the  or  button to select the function that you wish to reset.
- ▶ Press the  button.
- ▶ Press the  button to select **Yes** and press the  button to confirm.

You can reset the values of the following functions:

- Trip meter
- trip computer "From start"
- trip computer "From reset"

## Navigation menu

### Displaying navigation instructions

In the **Navi** menu, the multifunction display shows navigation instructions.

For further information, see the separate operating instructions.

- ▶ Switch on the audio system with Becker® MAP PILOT or COMAND Online, see the separate operating instructions.
- ▶ Press the  or  button on the steering wheel to select the **Navi** menu.

## Route guidance not active

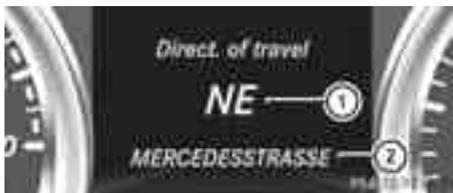

- ① Direction of travel
- ② Current street

## Activated route guidance

### No change of direction announced



- ① Distance to the destination
- ② Distance to the next change of direction
- ③ Current street
- ④ Symbol "follow the road's course"

### Change of direction announced without a lane recommendation

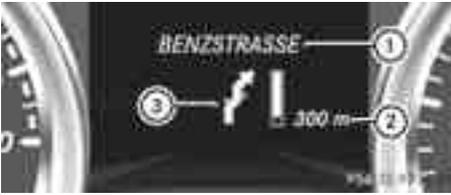

- ① Road to which the change of direction leads
- ② Distance to change of direction and visual distance display
- ③ Change-of-direction icon

When a change of direction has been announced, you will see visual distance display ② next to the symbol for change of direction ③. This shortens from the bottom to the top of the display as you approach the point of the announced change of direction.

### Change of direction announced with a lane recommendation



- ① Road to which the change of direction leads
- ② Distance to change of direction and visual distance display
- ③ Lane recommendation
- ④ New lane during a change of direction
- ⑤ Lane continues through change of direction
- ⑥ Change-of-direction icon

On multilane roads, the system can display lane recommendation ③ for the next change of direction. During the change of direction, additional lanes may be displayed.

Lane recommendations are only displayed if the relevant data is available on the digital map.

### Other status indicators of the navigation system

- : you have reached the destination or an intermediate destination.
- **New route...** or **Calculating route:** calculating a new route
- **Off map** or **Off road:** the vehicle position is outside the area of the digital map (off-map position).
- **No route:** no route could be calculated to the selected destination.

### Audio menu

#### Selecting a radio station



- ① Waveband
  - ② Channel frequency with memory position
- **i** Station ② is displayed with the station frequency or station name. The memory position is only displayed along with station ② if this has been stored.
  - ▶ Switch on the audio system or COMAND Online and select Radio, see the separate operating instructions.
  - ▶ Press the  or  button on the steering wheel to select the **Audio** menu.
  - ▶ **To select a stored channel:** briefly press the  or  button.

► **To select a station from the station list:**

press and briefly hold the  or  button.

If no station list is received:

► **To select a station using the station search:**

press and briefly hold the  or  button.

**i** For information on switching wavebands and storing stations, see the separate operating instructions.

**i** DAB radio mode (**D**igital **A**udio **B**roadcasting), see the separate operating instructions.

### Operating audio devices or media



Example: display CD/DVD changer

- ① Current CD in the CD/DVD changer
- ② Current track

Audio data from various audio devices or media can be played, depending on the equipment fitted in the vehicle.

- Switch on the audio system or COMAND Online and select the audio player or medium, see the separate operating instructions.
- Press the  or  button on the steering wheel to select the **Audio** menu.
- **To select the next/previous track:** briefly press the  or  button.
- **To select a track from the track list (rapid scrolling):** press and hold the  or  button until desired track ② has been reached.

If you press and hold  or , the rapid scrolling speed is increased. Not all

audio devices or media support this function.

If track information is stored on the audio device or medium, the multifunction display will show the number and title of the track. The current track does not appear in audio AUX mode (**A**uxiliary audio mode: external audio source connected).

### Video DVD operation



Example: display CD/DVD changer

- ① Current DVD in the CD/DVD changer
- ② Current scene

- Switch on the audio system or COMAND Online and select video DVD, see the separate operating instructions.
- Press the  or  button on the steering wheel to select the **Audio** menu.
- **To select the next or previous scene:** briefly press the  or  button.
- **To select a scene from the scene list (rapid scrolling):** press and hold the  or  button until desired scene ② has been reached.

### Telephone menu

#### Introduction

#### **WARNING**

Observe the legal requirements of the country in which you are currently driving regarding the use of mobile phones in the vehicle.

If it is permitted to use mobile phones while the vehicle is in motion, you should only use them when the road and traffic conditions allow. Otherwise, you may be distracted from

the traffic conditions, cause an accident and injure yourself and others.

- ▶ Switch on the mobile phone (see the separate operating instructions).
- ▶ Switch on the audio system or COMAND Online, see the separate operating instructions.
- ▶ Insert the mobile phone into the bracket (▷ page 279).

or

- ▶ Establish a Bluetooth® connection to the audio system or COMAND Online, see the separate operating instructions.
- ▶ Press the ◀ or ▶ button on the steering wheel to select the **TeI** menu.

You will see one of the following display messages in the multifunction display:

- **Please enter PIN:** the mobile phone has been placed in the mobile phone bracket and the PIN has not been entered.

When you enter your PIN via the mobile phone, LINGUATRONIC, the audio system or COMAND Online, the mobile phone searches for a network.

- **Telephone ready** or the name of the network provider: the mobile phone has found a network and is ready to receive.
- **Telephone No service:** there is no network available or the mobile phone is searching for a network.

**i** You can obtain further information about suitable mobile phones and connecting mobile phones via Bluetooth®:

- in any Mercedes-Benz Service Centre
- on the Internet at <http://www.mercedes-benz.com/connect>

## Accepting a call



Example: incoming call

If someone calls you when you are in the **TeI** menu, a display message appears in the multifunction display.

- ▶ Press the  button on the steering wheel to accept an incoming call.

You can accept a call even if you are not in the **TeI** menu.

## Rejecting or ending a call

- ▶ Press the  button on the steering wheel.

You can end or reject a call even if you are not in the **TeI** menu.

## Dialling a number from the phone book

- ▶ Press the ◀ or ▶ button on the steering wheel to select the **TeI** menu.
- ▶ Press the ▲, ▼ or **OK** button to switch to the phone book.
- ▶ Press the ▲ or ▼ button to select the desired name.

or

- ▶ **To begin rapid scrolling:** press and hold the ▲ or ▼ button for longer than one second. Rapid scrolling stops when you release the button or reach the end of the list.

- ▶ **If only one telephone number is stored for a name:** press the  or **OK** button to start dialling.

or

- ▶ **If there is more than one number for a particular name:** press the  or **OK** button to display the numbers.

- ▶ Press the  or  button to select the number you want to dial.
  - ▶ Press the  or  button to start dialing.
- or
- ▶ **To exit the telephone book:** press the  or  button.

### Redialling

The on-board computer saves the last names or numbers dialled in the redial memory.

- ▶ Press the  or  button on the steering wheel to select the **TeI** menu.
  - ▶ Press the  button to switch to the redial memory.
  - ▶ Press the  or  button to select the desired name or number.
  - ▶ Press the  or  button to start dialing.
- or
- ▶ **To exit the redial memory:** press the  or  button.

### Assistance menu

#### Introduction



In the **Assist.** menu, you have the following options:

- Show the distance display (▷ page 220).
- Activate/deactivate Blind Spot Assist or Active Blind Spot Assist (▷ page 220).

### Showing the distance display

- ▶ Press  or  on the steering wheel to select the **Assist.** menu.
- ▶ Press the  or  button to select **Distance display**.
- ▶ Press the  button.  
The DISTRONIC PLUS distance display appears in the multifunction display (▷ page 187).

### Activating/deactivating Blind Spot Assist

- ▶ Press  or  on the steering wheel to select the **Assist.** menu.
- ▶ Press the  or  button to select **Blind Spot Asst..**
- ▶ Press the  button.  
The current selection is displayed.
- ▶ **To activate/deactivate:** press the  button again.

For further information about Blind Spot Assist, see (▷ page 190).

For further information about Active Blind Spot Assist, see (▷ page 192).

### Service menu



Example: service menu

In the **Serv.** menu, you have the following options:

- call up display messages (▷ page 228)
- check the tyre pressure electronically (▷ page 324)
- call up when a service is due (▷ page 290)

## Settings menu

### Introduction



Example: settings menu

In the **Sett.** menu, you have the following options:

- change the instrument cluster settings (▷ page 221)
- change the light settings (▷ page 222)
- change the vehicle settings (▷ page 223)
- changing the auxiliary heating settings (▷ page 223)
- change the convenience settings (▷ page 224)
- restore the factory settings (▷ page 225)

### Instrument cluster

#### Selecting the unit of measurement for distance

The **Display unit Speed-/odometer** function allows you to choose whether certain displays appear in kilometres or miles in the multifunction display.

You can determine whether the multifunction display shows some messages in miles or kilometres.

- ▶ Press the or button on the steering wheel to select the **Settings** menu.
- ▶ Press the or button to select the **INST. CLUSTER** submenu.
- ▶ Press to confirm.

- ▶ Press the or button to select the **Display unit Speed-/odometer** function.

You will see the selected setting: **km** or **miles**.

- ▶ Press the button to save the setting.

The selected unit of measurement for distance applies to:

- **Vehicles with instrument cluster in kilometres:** digital speedometer in the **Trip** menu
- the total distance recorder and the trip meter
- the trip computer
- the current consumption and the range
- the navigation instructions in the **Navi** menu
- cruise control
- SPEEDTRONIC
- DISTRONIC PLUS
- ASSYST service interval display

#### Selecting the permanent display function

You can determine whether the multifunction display permanently shows your speed or the outside temperature.

- ▶ Press the or button on the steering wheel to select the **Settings** menu.
- ▶ Press the or button to select the **INST. CLUSTER** submenu.
- ▶ Press to confirm.
- ▶ Press the or button to select the **Permanent display:** function.  
You will see the selected setting: **outside temperature** or **Dig. speedom [mph]**.
- ▶ Press the button to save the setting.

Speed is displayed in mph.

Vehicles for the United Kingdom: this function is not available.

## Lights

### Setting the daytime driving lights

The **Day lights** function can only be switched on with the engine turned off.

- ▶ Press the  or  button on the steering wheel to select the **Settings** menu.
- ▶ Press the  or  button to select the **Light** submenu.
- ▶ Press  to confirm.
- ▶ Press  or  to select the **Daytime driving lights:** function.  
If the **Daytime driving lights** have been switched on, the cone of light and the  symbol in the multifunction display are shown in red.
- ▶ Press the  button to save the setting.

Further information on daytime driving lights (▷ page 105).

### Surround lighting and exterior lighting delayed switch-off

- ▶ Press the  or  button on the steering wheel to select the **Settings** menu.
- ▶ Press the  or  button to select the **Light** submenu.
- ▶ Press  to confirm.
- ▶ Press  or  to select the **Surround lighting** function.  
When the **Surround lighting** function is activated, the cone of light in the multifunction display is shown in red.
- ▶ Press the  button to save the setting.

Deactivating delayed switch-off of the exterior lighting temporarily:

- ▶ Before leaving the vehicle, turn the key to position **0** (▷ page 143) in the ignition lock.
- ▶ Turn the key to position **2** in the ignition lock (▷ page 143).  
The exterior lighting delayed switch-off is deactivated.

Delayed switch-off of the exterior lighting is reactivated the next time you start the engine.

If you have activated the **Surround lighting** function and the light switch is set to **Auto**, the following functions are activated when it is dark:

- **Surround lighting:** the exterior lighting remains lit for 40 seconds after unlocking with the key. If you start the engine, the surround lighting is switched off and automatic headlamp mode is activated (▷ page 105).
- **Exterior lighting delayed switch-off:** the exterior lighting remains lit for 60 seconds after the engine is switched off. If you close all the doors and the boot lid, the exterior lighting goes off after 15 seconds.

**i** Depending on your vehicle's equipment, when the surround lighting and delayed switch-off exterior lighting are on, the following light up:

- side lamps
- foglamps
- dipped-beam headlamps
- daytime driving lights
- surround lighting in the exterior mirrors

### Activating/deactivating the interior lighting delayed switch-off

If you activate the **Light. delay** function, the interior lighting remains on for 20 seconds after you remove the key from the ignition lock.

- ▶ Press the  or  button on the steering wheel to select the **Settings** menu.
- ▶ Press the  or  button to select the **Light** submenu.
- ▶ Press  to confirm.
- ▶ Press  or  to select the **Light. delay** function.  
When the **Light. delay** function is activated, the vehicle interior is displayed in red in the multifunction display.
- ▶ Press the  button to save the setting.

## Vehicle

### Setting permanent SPEEDTRONIC

- ▶ Press the  or  button on the steering wheel to select the **Settings** menu.
- ▶ Press the  or  button to select the **Vehicle** submenu.
- ▶ Press  to confirm.
- ▶ Press  or  to select the **Limit speed (winter tyres):** function. You will see the current setting.
- ▶ Press  to confirm.
- ▶ Press the  or  button to adjust permanent SPEEDTRONIC in increments of ten (230 km/h to 160 km/h). The **Off** setting switches permanent SPEEDTRONIC off.
- ▶ Press the  button to store the entry.

For further information on permanent SPEEDTRONIC (▷ page 182).

### Switching the automatic locking feature on/off

If you activate the **Auto. door locks** function, the vehicle is centrally locked above a speed of approximately 15 km/h.

- ▶ Press the  or  button on the steering wheel to select the **Settings** menu.
- ▶ Press the  or  button to select the **Vehicle** submenu.
- ▶ Press  to confirm.
- ▶ Press  or  to select the **Auto. door locks** function. When the **Auto. door locks** function is activated, the vehicle doors are displayed in red in the multifunction display.
- ▶ Press the  button to save the setting.

For further information on the automatic locking feature, see (▷ page 74).

### Activating/deactivating the acoustic locking confirmation

If you switch on the **Acoustic Lock** function, an acoustic signal sounds when you lock the vehicle.

- ▶ Press the  or  button on the steering wheel to select the **Settings** menu.
- ▶ Press the  or  button to select the **Vehicle** submenu.
- ▶ Press  to confirm.
- ▶ Press the  or  button to select the **Acoustic Lock** function. If the **Acoustic Lock** function is activated, the  symbol in the multifunction display lights up red.
- ▶ Press the  button to save the setting.

## Heating

### Auxiliary heating departure time

#### WARNING

Exhaust fumes are produced when the auxiliary heating is in operation. Inhaling these exhaust fumes can be poisonous. You should therefore switch off the auxiliary heating in confined spaces without an extraction system, e.g. a garage.

#### WARNING

When operating the auxiliary heating parts of the vehicle can get very hot. Make sure that the exhaust system does not under any circumstances come into contact with easily ignitable material such as dry grass or fuels. The material could otherwise ignite and set the vehicle alight. Choose your parking spot accordingly.

Operating the auxiliary heating is thus prohibited at filling stations or when your vehicle is being refuelled. You must therefore switch off the auxiliary heating at filling stations.

- ❗ Operating the auxiliary heating/ventilation draws on the vehicle battery. After you have heated or ventilated the vehicle a

maximum of two times, drive for a longer distance.

This function is only available on vehicles with auxiliary heating (▷ page 126).

In the **Heating** submenu, you can select a stored departure time or change a departure time.

The auxiliary heating timer function calculates the switch-on time according to the outside temperature so that the vehicle is pre-heated by the departure time. When the departure time is reached, the auxiliary heating continues to heat for a further five minutes and then switches off. The auxiliary heating adopts the THERMATIC temperature setting.

You can switch off the auxiliary heating by using the remote control or the  auxiliary heating button on the centre console.

### Selecting the departure time or deactivating a selected departure time

- ▶ Press the  or  button on the steering wheel to select the **Settings** menu.
- ▶ Press the  or  button to select the **Heating** submenu.
- ▶ Press  to confirm.  
You will see the selected setting.
- ▶ Press  to confirm.
- ▶ Press the  or  button to select one of the three departure times or **Timer off** (no timer active).
- ▶ Press  to confirm.  
If a departure time is selected, the yellow indicator lamp lights up on the  auxiliary heating button.

### Changing the departure time

- ▶ Press the  or  button on the steering wheel to select the **Settings** menu.
- ▶ Press the  or  button to select the **Heating** submenu.
- ▶ Press  to confirm.  
You will see the selected setting.

- ▶ Press  to confirm.
- ▶ Press the  or  button to select **Change A, B or C**.
- ▶ Press  to confirm.  
You can now change the departure time.
- ▶ Press the  or  button to select the display to be changed: hours, minutes.
- ▶ Press the  or  button to set the selected display.
- ▶ Press the  button to store the entry.  
The yellow indicator lamp on the  auxiliary heating button lights up.

## Convenience

### Activating/deactivating the EASY-ENTRY/EXIT feature

#### WARNING

The steering wheel moves when the EASY-ENTRY/EXIT feature is active. There is a risk of occupants becoming trapped. Before activating the EASY-ENTRY/EXIT feature, make sure that nobody can become trapped.

Do not leave children unsupervised in the vehicle, even if they are secured in a child restraint system. The children could open the driver's door and thereby unintentionally activate the EASY-ENTRY/EXIT feature and become trapped.

- ▶ Press the  or  button on the steering wheel to select the **Settings** menu.
  - ▶ Press the  or  button to select the **CONVENIENCE** submenu.
  - ▶ Press  to confirm.
  - ▶ Press  or  to select the **Easy Entry/Exit**: function.  
If the **Easy Entry/Exit** function is activated, the vehicle steering wheel is displayed in red in the multifunction display.
  - ▶ Press the  button to save the setting.
- Further information on the EASY-ENTRY/EXIT feature (▷ page 98).

### Switching the fold-in mirrors when locking function on/off

When you activate the **Auto. fold in mirrors** function, the exterior mirrors are folded in when the vehicle is locked. When you unlock the vehicle and then open a door, the exterior mirrors fold out again.

- ▶ Press the ◀ or ▶ button on the steering wheel to select the **Settings** menu.
  - ▶ Press the ▼ or ▲ button to select the **CONVENIENCE** submenu.
  - ▶ Press **OK** to confirm.
  - ▶ Press ▼ or ▲ to select the **Auto. fold in mirrors** function.
- If the **Auto. fold in mirrors** function is activated, the vehicle's exterior mirror is displayed in red in the multifunction display.
- ▶ Press the **OK** button to save the setting.

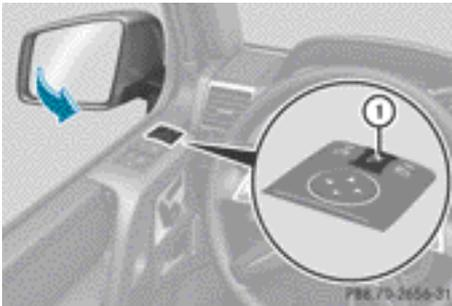

① To fold the exterior mirrors in or out

If you have switched the **Auto. fold-in function** on and you fold the exterior mirrors in using button ①, they will not fold out automatically (▷ page 99).

You can then only fold out the exterior mirrors using button ①.

### Resetting to factory settings

- ▶ Press the ◀ or ▶ button on the steering wheel to select the **Settings** menu.
- ▶ Press the ▼ or ▲ button to select the **Factory settings** submenu.

- ▶ Press **OK** to confirm.  
The **Reset all settings?** message appears.
- ▶ Press the ▼ or ▲ button to select **No** or **Yes**.
- ▶ Press the **OK** button to confirm the selection.  
If you have selected **Yes**, the multifunction display shows a confirmation message.

For safety reasons, not all functions are reset: the **Limit speed (winter tyres)** function in permanent SPEEDTRONIC can only be set in the **Vehicle** submenu. If you want to reset the **Daytime driving lights** in the **Light** submenu, you must turn the key to position 1 (▷ page 143) in the ignition lock.

### AMG menu in AMG vehicles

#### AMG displays



- ① Digital speedometer
- ② Gear indicator
- ③ Upshift indicator
- ④ Engine oil temperature
- ⑤ Coolant temperature
- ⑥ Status indicator for ECO start/stop function (▷ page 145)

- ▶ Press ◀ or ▶ on the steering wheel to select the **AMG** menu.

Upshift indicator **UP** ③ indicates that the engine has reached the overrevving range when in the manual gearshift program. Upshift indicator **UP** ③ fades out other messages until you have shifted up.

If the engine oil temperature is below 80 °C, the oil temperature is shown in blue. Avoid

using the full output of the engine during this time.

## SETUP



- ① Drive program (C/SS+/M)
- ② ESP® mode (ON/OFF)
- ③ Suspension tuning (SPORT/COMFORT)

SETUP shows the drive program, the ESP® (Electronic Stability Program) mode and the SPORT handling mode.

- ▶ Press or on the steering wheel to select the **AMG** menu.
- ▶ Press the button repeatedly until SETUP is displayed.

## RACETIMER

### Displaying and starting the RACETIMER

#### WARNING

The RACETIMER feature is only for use on roads and in conditions where high speed driving is permitted. Racing on public roads is prohibited under all circumstances. The driver is and must always remain responsible for following posted speed limits.



- ① Lap
- ② RACETIMER

You can start the RACETIMER when the engine is running or if the key is in position **2** (▶ page 143) in the ignition lock.

- ▶ Press or on the steering wheel to select the **AMG** menu.
- ▶ Press the button repeatedly until the RACETIMER is shown.
- ▶ **To start:** press the button to start the RACETIMER.

### Displaying the intermediate time

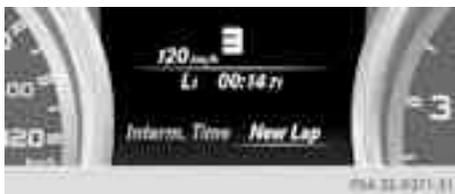

- ▶ Press the or button to select **Interm. Time**.
- ▶ Press to confirm.  
The intermediate time is displayed for five seconds.

### Starting a new lap



- ① RACETIMER
  - ② Fastest lap time (best lap)
  - ③ Lap
- ▶ Press to confirm **New Lap**.

**i** It is possible to store a maximum of sixteen laps. The 16th lap can only be completed with **Finish Lap**.

### Stopping the RACETIMER



- ▶ Press the  button on the steering wheel.
- ▶ Press  to confirm **Yes**.

The RACETIMER is interrupted if you stop the vehicle and turn the key to position 1 (▶ page 143) in the ignition lock. If you turn the key to position 2 or 3 (▶ page 143) and then press  to confirm **Start**, timing is continued.

### Resetting the current lap

- ▶ Stop the RACETIMER (▶ page 226).
- ▶ Press  or  to select **Reset Lap**.
- ▶ Press  to reset the lap time to "0".

### Deleting all laps



If you switch off the engine, the RACETIMER is reset to "0" after 30 seconds. All laps are deleted.

You cannot delete individual stored laps. If you have stopped 16 laps, the current lap does not have to be reset.

- ▶ Reset the current lap (▶ page 227).
- ▶ Press  to confirm **Reset**. **Reset Race Timer?** appears in the multi-function display.
- ▶ Press the  button to select **Yes** and press the  button to confirm. All laps are deleted.

### Overall evaluation



- ① RACETIMER overall evaluation
- ② Total time driven
- ③ Average speed
- ④ Distance covered
- ⑤ Maximum speed

This function is shown if you have stored at least one lap and stopped the RACETIMER.

- ▶ Press  or  on the steering wheel to select the **AMG** menu.
- ▶ Press the  button repeatedly until the overall evaluation is shown.

### Lap evaluation

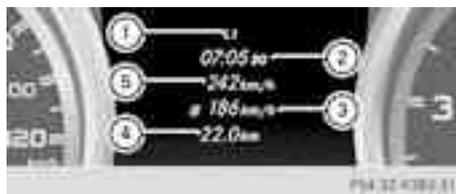

- ① Lap
- ② Lap time
- ③ Average lap speed
- ④ Lap length
- ⑤ Top speed during lap

This function is only available if you have stored at least two laps and have stopped the RACETIMER.

- ▶ Press  or  on the steering wheel to select the **AMG** menu.
- ▶ Press the  button repeatedly until the lap evaluation is shown. Each lap is shown in a separate submenu. The fastest lap is indicated by flashing symbol ①.
- ▶ Press the  or  button to select a different lap evaluation.

## Display messages

### Introduction

#### General notes

Display messages appear in the multifunction display.

Display messages with graphic symbols are simplified in the Owner's Manual and may differ from the symbols in the multifunction display.

Please respond in accordance with the display messages and follow the additional notes in this Owner's Manual.

Certain display messages are accompanied by an audible warning tone or a continuous tone.

When you stop and park the vehicle, please observe the notes on:

- HOLD function (▷ page 196)
- Parking (▷ page 163)

#### Hiding display messages

- ▶ Press the  or  button on the steering wheel to hide the display message. The display message is cleared.

High-priority display messages are red.

You cannot hide display messages of the highest priority. The multifunction display shows these messages continuously until the

causes for the messages have been remedied.

#### Message memory menu

The on-board computer saves certain display messages. You can call up the display messages in the **message memory**.

- ▶ Press the  or  button on the steering wheel to select the **Serv.** menu. If there are display messages, the multi-function display shows **2 messages**, for example.
- ▶ Press the  or  button to select the entry, e.g. **2 messages**.
- ▶ Press  to confirm.
- ▶ Press the  or  button to scroll through the display messages.

When the ignition is switched off, all display messages are deleted apart from some high-priority display messages. Once the causes of the high-priority display messages have been rectified, the corresponding display messages are also deleted.

## Safety systems

## Display messages



currently unavailable See Owner's Manual

## Possible causes/consequences and ► Solutions

ABS (Anti-lock Braking System), ESP® (Electronic Stability Program), BAS (Brake Assist), the HOLD function, hill start assist and ESP® trailer stabilisation are temporarily unavailable.

BAS and the adaptive brake lights may also have failed.

In addition, the ,  and  warning lamps light up in the instrument cluster.

Possible causes:

- Self-diagnosis is not yet complete.
- The on-board voltage may be insufficient.

 **WARNING**

The brake system continues to function normally, but without the functions listed above. The wheels could therefore lock if you brake hard, for example.

The steerability and braking characteristics may be severely affected. The braking distance in an emergency braking situation can increase.

If ESP® is not operational, ESP® is unable to stabilise the vehicle. The danger of skidding and having an accident increases.

► Carefully drive on a suitable stretch of road making slight steering movements at a speed above 20 km/h.

If the display message disappears, the functions mentioned above are available again.

If the display message continues to be displayed:

- Drive on carefully.
- Visit a qualified specialist workshop.



inoperative See Owner's Manual

ABS, ESP®, BAS, the HOLD function, hill start assist and ESP® trailer stabilisation are unavailable due to a malfunction.

BAS and the adaptive brake lights may also have failed.

In addition, the , ,  and  warning lamps light up in the instrument cluster.

 **WARNING**

The brake system continues to function normally, but without the functions listed above. The wheels could therefore lock if you brake hard, for example.

The steerability and braking characteristics may be severely affected. The braking distance in an emergency braking situation can increase.

Display messages	Possible causes/consequences and ► Solutions
	<p>If ESP® is not operational, ESP® is unable to stabilise the vehicle. The danger of skidding and having an accident increases.</p> <ul style="list-style-type: none"> <li>► Drive on carefully.</li> <li>► Visit a qualified specialist workshop immediately.</li> </ul>
<div style="display: flex; align-items: center;">  <div style="margin-left: 10px;"> <p>currently unavailable See Owner's Manual</p> </div> </div>	<p>ESP®, BAS, the HOLD function, hill start assist and ESP® trailer stabilisation are unavailable due to a malfunction. BAS and the adaptive brake lights may also have failed. In addition, the  and  warning lamps light up in the instrument cluster. The self-diagnosis function may not be complete, for example.</p> <p><b>⚠ WARNING</b></p> <p>The brake system continues to function normally, but without the functions listed above. The braking distance in an emergency braking situation can thus increase.</p> <p>If ESP® is not operational, ESP® is unable to stabilise the vehicle. The danger of skidding and having an accident increases.</p> <ul style="list-style-type: none"> <li>► Carefully drive on a suitable stretch of road making slight steering movements at a speed above 20 km/h. If the display message disappears, the functions mentioned above are available again.</li> </ul> <p>If the display message continues to be displayed:</p> <ul style="list-style-type: none"> <li>► Drive on carefully.</li> <li>► Visit a qualified specialist workshop.</li> </ul>

Display messages	Possible causes/consequences and ► Solutions
 <p data-bbox="115 229 309 284">inoperative See Owner's Manual</p>	<p data-bbox="370 177 1020 236">ESP®, BAS, the HOLD function, hill start assist and ESP® trailer stabilisation are unavailable due to a malfunction.</p> <p data-bbox="370 244 938 269">BAS and the adaptive brake lights may also have failed.</p> <p data-bbox="370 277 992 336">In addition, the  and  warning lamps light up in the instrument cluster.</p> <p data-bbox="381 352 535 379"><b>▲ WARNING</b></p> <p data-bbox="370 395 1034 451">The brake system continues to function normally, but without the functions listed above.</p> <p data-bbox="370 459 1034 515">The braking distance in an emergency braking situation can thus increase.</p> <p data-bbox="370 523 1034 549">If ESP® is not operational, ESP® is unable to stabilise the vehicle.</p> <p data-bbox="370 557 958 582">The danger of skidding and having an accident increases.</p> <ul data-bbox="370 598 766 657" style="list-style-type: none"> <li>► Drive on carefully.</li> <li>► Visit a qualified specialist workshop.</li> </ul>
  <p data-bbox="115 788 309 842">inoperative See Owner's Manual</p>	<p data-bbox="370 687 1025 775">EBD (electronic brake force distribution), ABS, ESP®, BAS, the HOLD function, hill start assist and ESP® trailer stabilisation are unavailable due to a malfunction.</p> <p data-bbox="370 783 938 809">BAS and the adaptive brake lights may also have failed.</p> <p data-bbox="370 817 1020 876">In addition, the ,  and  warning lamps light up in the instrument cluster and a warning tone sounds.</p> <p data-bbox="381 892 535 919"><b>▲ WARNING</b></p> <p data-bbox="370 935 1034 1023">The brake system continues to function normally, but without the functions listed above. The front and rear wheels could therefore lock if you brake hard, for example.</p> <p data-bbox="370 1031 1034 1110">The steerability and braking characteristics may be severely affected. The braking distance in an emergency braking situation can increase.</p> <p data-bbox="370 1118 1034 1144">If ESP® is not operational, ESP® is unable to stabilise the vehicle.</p> <p data-bbox="370 1152 958 1177">The danger of skidding and having an accident increases.</p> <ul data-bbox="370 1193 897 1252" style="list-style-type: none"> <li>► Drive on carefully.</li> <li>► Visit a qualified specialist workshop immediately.</li> </ul>
 <p data-bbox="115 1342 309 1396">Release parking brake</p>	<p data-bbox="370 1289 1034 1345">You are driving with the parking brake applied. A warning tone also sounds.</p> <ul data-bbox="370 1361 669 1386" style="list-style-type: none"> <li>► Release the parking brake.</li> </ul>

Display messages	Possible causes/consequences and ► Solutions
 <p data-bbox="85 228 303 284">Check brake fluid level</p>	<p data-bbox="342 177 1005 260">There is insufficient brake fluid in the brake fluid reservoir. In addition, the  warning lamp in the instrument cluster lights up and a warning tone sounds.</p> <p data-bbox="353 284 505 308"> <b>WARNING</b></p> <p data-bbox="342 323 748 347">The braking efficiency may be impaired.</p> <p data-bbox="342 355 641 379">There is a risk of an accident.</p> <ul data-bbox="342 395 1005 587" style="list-style-type: none"> <li>► Pull over and stop the vehicle safely as soon as possible, paying attention to road and traffic conditions. Do not continue driving under any circumstances.</li> <li>► Secure the vehicle against rolling away (▷ page 163).</li> <li>► Consult a qualified specialist workshop.</li> <li>► Do not top up the brake fluid. This does not correct the error.</li> </ul>
 <p data-bbox="85 670 277 726">Check brake pad wear</p>	<p data-bbox="342 619 888 643">The brake pads/linings have reached their wear limit.</p> <ul data-bbox="342 659 736 683" style="list-style-type: none"> <li>► Visit a qualified specialist workshop.</li> </ul>
	<p data-bbox="342 746 966 802">If the symbol appears in the multifunction display, a seat belt tongue has been inserted into a rear seat belt buckle.</p> <p data-bbox="342 810 1005 866">Further information on the status indicator for the rear seat belts (▷ page 47).</p>
	<p data-bbox="342 890 966 946">If the symbol appears in the multifunction display, a seat belt tongue has not been inserted in a rear seat belt buckle.</p> <p data-bbox="353 970 505 994"> <b>WARNING</b></p> <p data-bbox="342 1010 972 1090">A seat belt which is not worn correctly, or which has not been engaged in the seat belt buckle correctly, cannot provide the intended level of protection.</p> <p data-bbox="342 1106 725 1129">This poses an increased risk of injury.</p> <ul data-bbox="342 1145 1005 1201" style="list-style-type: none"> <li>► If necessary, ask the occupants in the rear to fasten their seat belts (▷ page 44).</li> </ul> <p data-bbox="342 1217 1005 1265">Further information on the status indicator for the rear seat belts (▷ page 47).</p>

Display messages	Possible causes/consequences and ► Solutions
 <p>Restraint syst. malfunction Consult workshop</p>	<p>There is a malfunction in the SRS (Supplemental Restraint System). The  warning lamp also lights up in the instrument cluster.</p> <p> <b>WARNING</b></p> <p>The airbags or belt tensioners may either be triggered unintentionally or, in the event of an accident, may not be triggered. This poses an increased risk of injury.</p> <p>► Visit a qualified specialist workshop.</p> <p>For further information about the Supplemental Restraint System, see (► page 39).</p>
 <p>Front left malfunction Consult workshop or Front right malfunction Consult workshop</p>	<p>SRS has malfunctioned at the front on the left or right. The  warning lamp also lights up in the instrument cluster.</p> <p> <b>WARNING</b></p> <p>The airbags or belt tensioners may either be triggered unintentionally or, in the event of an accident, may not be triggered. This poses an increased risk of injury.</p> <p>► Visit a qualified specialist workshop.</p>
 <p>Rear left malfunction Consult workshop or Rear right malfunction Consult workshop</p>	<p>SRS has malfunctioned at the rear on the left or right. The  warning lamp also lights up in the instrument cluster.</p> <p> <b>WARNING</b></p> <p>The airbags or belt tensioners may either be triggered unintentionally or, in the event of an accident, may not be triggered. This poses an increased risk of injury.</p> <p>► Visit a qualified specialist workshop.</p>

Display messages	Possible causes/consequences and ► Solutions
 <p>Rear centre malfunction Consult workshop</p>	<p>SRS has malfunctioned at the rear centre. The  warning lamp also lights up in the instrument cluster.</p> <p> <b>WARNING</b></p> <p>The airbags or belt tensioners may either be triggered unintentionally or, in the event of an accident, may not be triggered. This poses an increased risk of injury.</p> <p>► Visit a qualified specialist workshop.</p>
 <p>Left windowbag malfunction Consult workshop or Right windowbag malfunction Consult workshop</p>	<p>There is a malfunction in the left-hand and/or right-hand windowbag. The  warning lamp also lights up in the instrument cluster.</p> <p> <b>WARNING</b></p> <p>The left or right windowbag may either be triggered unintentionally or, in the event of an accident, may not be triggered. This poses an increased risk of injury.</p> <p>► Visit a qualified specialist workshop.</p>

## Lights

### **i** Display messages about LEDs:

This display message will only appear if all LEDs have failed.

Display messages	Possible causes/consequences and ► Solutions
 <p>Left dipped beam or Right dipped beam</p>	<p>The left or right-hand dipped-beam headlamp is faulty.</p> <p>► Visit a qualified specialist workshop.</p>
 <p>Trailer left tail lamp or Trailer right tail lamp</p>	<p>The left or right-hand trailer tail lamp is faulty.</p> <p>► Check whether you are permitted to replace the bulb yourself. or</p> <p>► Visit a qualified specialist workshop.</p>
 <p>Trailer left indicator or Trailer right indicator</p>	<p>The left or right-hand trailer turn signal lamp is faulty.</p> <p>► Check whether you are permitted to replace the bulb yourself. or</p> <p>► Visit a qualified specialist workshop.</p>

Display messages	Possible causes/consequences and ► Solutions
 Trailer brake lamp	<p>The trailer brake lamp is faulty.</p> <ul style="list-style-type: none"> <li>► Check whether you are permitted to replace the bulb yourself.</li> </ul> <p>or</p> <ul style="list-style-type: none"> <li>► Visit a qualified specialist workshop.</li> </ul>
 Rear left indicator or Rear right indicator	<p>The rear left-hand or rear right-hand turn signal is faulty.</p> <ul style="list-style-type: none"> <li>► Check whether you are permitted to replace the bulb yourself (► page 115).</li> </ul> <p>or</p> <ul style="list-style-type: none"> <li>► Visit a qualified specialist workshop.</li> </ul>
 Front left indicator or Front right indicator	<p>The front left-hand or front right-hand turn signal is faulty.</p> <ul style="list-style-type: none"> <li>► Check whether you are permitted to replace the bulb yourself (► page 115).</li> </ul> <p>or</p> <ul style="list-style-type: none"> <li>► Visit a qualified specialist workshop.</li> </ul>
 Left mirror indicator or Right mirror indicator	<p>The turn signal in the left-hand or right-hand exterior mirror is faulty.</p> <ul style="list-style-type: none"> <li>► Visit a qualified specialist workshop.</li> </ul>
 Third brake lamp	<p>The third brake lamp is faulty.</p> <ul style="list-style-type: none"> <li>► Visit a qualified specialist workshop.</li> </ul>
 Left brake lamp or Right brake lamp	<p>The left or right-hand brake lamp is faulty.</p> <ul style="list-style-type: none"> <li>► Replace the bulb (► page 114).</li> </ul>
 Left main beam or Right main beam	<p>The left or right-hand high beam is faulty.</p> <ul style="list-style-type: none"> <li>► Visit a qualified specialist workshop.</li> </ul>
 Number plate lamp	<p>There is a short circuit in the LEDs. The LEDs have been switched off.</p> <ul style="list-style-type: none"> <li>► Visit a qualified specialist workshop.</li> </ul>

Display messages	Possible causes/consequences and ► Solutions
 <p>Front fog lamp, left or Front fog- lamp, right</p>	<p>The left-hand or right-hand front foglamp is faulty.</p> <p>► Replace the bulb (▷ page 114).</p>
 <p>Rear fog lamp</p>	<p>The rear foglamp is faulty.</p> <p>► Check whether you are permitted to replace the bulb yourself (▷ page 115).</p> <p>or</p> <p>► Visit a qualified specialist workshop.</p>
 <p>Front left parking lamp or Front right parking lamp</p>	<p>The front left or front right parking lamp is faulty.</p> <p>► Check whether you are permitted to replace the bulb yourself (▷ page 115).</p> <p>or</p> <p>► Visit a qualified specialist workshop.</p>
 <p>Reversing light</p>	<p>The reversing lamp is faulty.</p> <p>► Replace the bulb (▷ page 114).</p>
 <p>Left tail lamp or Right tail lamp</p>	<p>The left or right-hand tail lamp is faulty.</p> <p>► Check whether you are permitted to replace the bulb yourself (▷ page 115).</p> <p>or</p> <p>► Visit a qualified specialist workshop.</p>
 <p>Left daytime driv- ing lamp or Right daytime driving lamp</p>	<p>The left or right-hand daytime driving lamp is defective.</p> <p>► Visit a qualified specialist workshop.</p>
 <p>Malfunction See Owner's Manual</p>	<p>The exterior lighting is faulty.</p> <p>► Visit a qualified specialist workshop.</p>
 <p>AUTO lights inoper- ative</p>	<p>The light sensor is faulty.</p> <p>► Visit a qualified specialist workshop.</p>

Display messages	Possible causes/consequences and ► Solutions
 Remove key	You have left the key in the ignition lock. ► Remove the key from the ignition lock.
 Switch off lights	The lights are still switched on when you leave the vehicle. A warning tone also sounds. ► Turn the light switch to <b>AUTO</b> .

Engine	
Display messages	Possible causes/consequences and ► Solutions
 Top up coolant See Owner's Manual	The coolant level is too low. ► Top up the coolant, observing the warning notes before doing so (► page 289). ► Have the coolant system checked at a qualified specialist workshop if the coolant needs topping up more often than usual.
	The fan motor is faulty. ► If the coolant temperature is below 120 °C, you can continue driving to the nearest qualified specialist workshop. ► Avoid heavy loads on the engine as you do so, e.g. driving in mountainous terrain and stop-start traffic.

## Display messages



Coolant Stop vehicle Switch engine off

## Possible causes/consequences and ► Solutions

The coolant is too hot.  
A warning tone also sounds.

 **WARNING**

Never drive with an overheated engine. Driving when your engine is overheated can cause some fluids which may have leaked into the engine compartment to catch fire.

Steam from an overheated engine can cause serious burns which can occur just by opening the bonnet.

There is a risk of injury.

- Stop the vehicle immediately, paying attention to road and traffic conditions, and switch off the engine.
- Secure the vehicle against rolling away (▷ page 163).
- Leave the vehicle and keep a safe distance from the vehicle until the engine has cooled down.
- Make sure that the air supply to the engine radiator is not blocked, e.g. by frozen slush.
- Do not start the engine again until the display message goes out and the coolant temperature is below 120 °C. The engine may otherwise be damaged.
- Pay attention to the coolant temperature display.
- If the temperature increases again, visit a qualified specialist workshop immediately.

Under normal operating conditions and with the specified coolant level, the coolant temperature may rise to 120 °C.

The poly-V-belt may have torn.

- Stop the vehicle immediately, paying attention to road and traffic conditions, and switch off the engine.
- Check the poly-V-belt.

**If the poly-V-belt is torn:**

-  Do not continue driving. The engine could otherwise overheat.
- Consult a qualified specialist workshop.

**If the poly-V-belt is OK:**

- Wait until the display message disappears before restarting the engine. The engine may otherwise be damaged.
- Pay attention to the coolant temperature display.
- Visit a qualified specialist workshop.

Display messages	Possible causes/consequences and ► Solutions
	<p>The battery is not being charged. A warning tone also sounds.</p> <p>Possible causes:</p> <ul style="list-style-type: none"> <li>• faulty alternator</li> <li>• torn poly-V-belt</li> <li>• a malfunction in the electronics</li> </ul> <p>► Stop the vehicle immediately, paying attention to road and traffic conditions, and switch off the engine.</p> <p>► Open the bonnet.</p> <p>► Check whether the poly-V-belt is torn.</p> <p><b>If the poly-V-belt is torn:</b></p> <p><b>!</b> Do not continue driving. The engine could otherwise overheat.</p> <p>► Consult a qualified specialist workshop.</p> <p><b>If the poly-V-belt is OK:</b></p> <p>► Visit a qualified specialist workshop.</p>
 <p>Check eng. oil lev. when next refuelling</p>	<p>The engine oil level has dropped to the minimum level. A warning tone also sounds.</p> <p>► Check the oil level when next refuelling, at the latest (&gt; page 287).</p> <p>► If necessary, top up the engine oil (&gt; page 289).</p> <p>► Have the engine checked at a qualified specialist workshop if the engine oil needs topping up more often than usual.</p>
 <p>Engine oil level Stop vehicle Turn engine off</p>	<p>The engine oil level is too low. There is a risk of engine damage.</p> <p>► Stop the vehicle immediately, paying attention to road and traffic conditions, and switch off the engine.</p> <p>► Top up the engine oil (&gt; page 289) and check the oil level (&gt; page 287).</p>
 <p>Add 1 litre engine oil when next refuelling</p>	<p>AMG vehicles: the engine oil level is too low.</p> <p>► Check the oil level when next refuelling, at the latest (&gt; page 287).</p> <p>► If necessary, top up the engine oil (&gt; page 289).</p> <p>► Have the engine checked at a qualified specialist workshop if the engine oil needs topping up more often than usual.</p>
 <p>Cannot measure engine oil level</p>	<p>The measuring system is malfunctioning.</p> <p>► Visit a qualified specialist workshop.</p>

Display messages	Possible causes/consequences and ► Solutions
 Reserve fuel level	<p>The fuel level has dropped into the reserve range.            Operation of the auxiliary heating is deactivated when the fuel level drops into the reserve range.</p> <p>► Refuel at the nearest filling station.</p>
 Reserve fuel level	<p>There is only a very small amount of fuel in the fuel tank.            The auxiliary heating cannot be operated.</p> <p>► Refuel at the nearest filling station without fail.</p>
 Replace air cleaner	<p><b>Vehicles with a diesel engine:</b> the engine air filter is dirty and must be replaced.</p> <p>► Visit a qualified specialist workshop.</p>
 Clean the fuel filter	<p><b>Vehicles with a diesel engine:</b> there is water in the fuel filter.            The water must be drained off.</p> <p>► Visit a qualified specialist workshop.</p>
 Refill AdBlue See Owner's Manual	<p>The AdBlue<sup>®</sup> level has fallen below the reserve range. A warning tone also sounds.</p> <p>► Have AdBlue<sup>®</sup> refilled as soon as possible at a qualified specialist workshop.</p> <p>or</p> <p>► Refill AdBlue<sup>®</sup> yourself as soon as possible (▷ page 160).</p>
 Refill AdBlue No start in .. km	<p>The AdBlue<sup>®</sup> level is only sufficient for the indicated distance. A warning tone also sounds.</p> <p>► Have AdBlue<sup>®</sup> refilled as soon as possible at a qualified specialist workshop.</p> <p>or</p> <p>► Refill AdBlue<sup>®</sup> yourself immediately (▷ page 160).</p>
 Refill AdBlue Eng. start not possible	<p>The AdBlue<sup>®</sup> tank is empty. A warning tone also sounds. You can no longer start the engine.</p> <p>► Consult a qualified specialist workshop immediately.</p> <p>or</p> <p>► Refill AdBlue<sup>®</sup> yourself immediately (▷ page 160).</p>
 Check AdBlue See Owner's Manual	<p>The AdBlue<sup>®</sup> system is malfunctioning. A warning tone also sounds.</p> <p>► Visit a qualified specialist workshop.</p>

Display messages	Possible causes/consequences and ► Solutions
 <p>Eng. start not possible in ... km</p>	<p>The AdBlue® system is malfunctioning. A warning tone also sounds.</p> <ul style="list-style-type: none"> <li>► Visit a qualified specialist workshop immediately.</li> </ul>
 <p>Engine start not possible</p>	<p>The AdBlue® system is malfunctioning. A warning tone also sounds. You can no longer start the engine.</p> <ul style="list-style-type: none"> <li>► Consult a qualified specialist workshop immediately.</li> </ul>

Driving systems	
Display messages	Possible causes/consequences and ► Solutions
<p>TC shift conditions not fulfilled Apply the brake/ parking brake</p>	<p>The parking brake has not been applied and the brake pedal has not been depressed. The transfer case has cancelled the gear change process and is in <b>Neutral</b>. There is no connection between the engine and the drive wheels.</p> <ul style="list-style-type: none"> <li>► Pull over and stop the vehicle safely as soon as possible, paying attention to road and traffic conditions.</li> <li>► Depress the brake pedal and apply the parking brake.</li> <li>► Shift the automatic transmission to neutral position <b>N</b>.</li> <li>► Make sure all conditions for changing gears are met (&gt; page 202).</li> <li>► Repeat the gearshift process.</li> </ul>
<p>TC malfunction Visit workshop To park, apply the parking brake</p>	<p>There is a malfunction in the transfer case.</p> <ul style="list-style-type: none"> <li>► Do not shift the transfer case.</li> <li>► When parking, secure the vehicle against rolling away (&gt; page 163).</li> <li>► Have the vehicle checked at a qualified specialist workshop.</li> </ul>
<p>TC shift procedure cancelled Reactivate</p>	<p>The transfer case has not performed the gear change process.</p> <ul style="list-style-type: none"> <li>► Repeat the gearshift process.</li> <li>► Make sure all conditions for changing gears are met (&gt; page 202).</li> </ul>
<p>TC shift condition not fulfilled Drive at max. 40 km/h</p>	<p>You have exceeded the maximum speed for the gearshift process.</p> <ul style="list-style-type: none"> <li>► Drive more slowly.</li> <li>► Repeat the gearshift process.</li> </ul>

Display messages	Possible causes/consequences and ► Solutions
TC shift condition not fulfilled Engage NEUTRAL gear	You have not met one or more shift conditions. ► Shift the automatic transmission to neutral position <b>N</b> . ► Repeat the gearshift process.
TC shift condition not fulfilled Drive at max. 70 km/h	You have exceeded the maximum speed for the gearshift process. ► Drive more slowly. ► Repeat the gearshift process.
LOW RANGE On	The transfer case is in the <b>LOW RANGE</b> off-road position.
HIGH RANGE On	The transfer case is in the <b>HIGH RANGE</b> on-road position.
Differential locks available only in LOW RANGE	The LOW RANGE button has been pressed. The transfer case is in the <b>LOW RANGE</b> off-road driving position and a differential lock is engaged. ► Disengage the differential locks (▷ page 204). ► Repeat the gearshift process.
TC-NEUTRAL On	The transfer case is in the <b>Neutral</b> neutral position. A warning tone will also sound when the driver's door is opened and the brake pedal is not depressed. ► Close the driver's door. ► Secure the vehicle against rolling away (▷ page 163). ► Shift the transfer case according to driving conditions (▷ page 201).
Preselected differential lock ESP not available	A differential lock has been engaged. The differential gear has not yet locked the respective differential. The activation indicator lamp (yellow) (▷ page 204) of the switch lights up. ESP is unavailable. ABS is still available.
Differential locks active ABS and ESP unavailable	A differential lock was engaged and the differential gear has locked the respective differential. The activation indicator lamp (yellow) and function indicator lamp (red) (▷ page 204) on the switch light up. ABS and ESP are unavailable.

Display messages	Possible causes/consequences and ► Solutions
<p>Blind Spot Assist currently unavailable See Owner's Manual or Active Blind Spot Assist currently unavailable See Owner's Manual</p>	<p>Blind Spot Assist or Active Blind Spot Assist is temporarily inoperative. Possible causes:</p> <ul style="list-style-type: none"> <li>• you have established the electrical connection between the trailer and your vehicle.</li> <li>• the sensors are dirty.</li> <li>• the function is impaired due to heavy rain or snow.</li> <li>• the radar sensor system is outside the operating temperature range.</li> <li>• the radar sensor system is temporarily inoperative, e.g. due to electromagnetic radiation emitted by nearby TV or radio stations or other sources of electromagnetic radiation.</li> </ul> <p>The yellow  indicator lamps also light up in the exterior mirrors.</p> <p>► When towing a trailer, confirm the display message with .</p> <p>If you are driving without a trailer and the display message does not disappear:</p> <ul style="list-style-type: none"> <li>► Pull over and stop the vehicle safely as soon as possible, paying attention to road and traffic conditions.</li> <li>► Engage the parking brake.</li> <li>► Clean the sensors (▷ page 294).</li> <li>► Restart the engine.</li> </ul> <p>If the system detects that the sensors are fully operational, the display message disappears.</p> <p>Blind Spot Assist or Active Blind Spot Assist is operational again.</p>
<p>Blind Spot Assist inoperative or Active Blind Spot Assist inoperative</p>	<p>Blind Spot Assist or Active Blind Spot Assist is faulty.</p> <p>The yellow  indicator lamps also light up in the exterior mirrors.</p> <p>► Visit a qualified specialist workshop.</p>
<p>DISTRONIC PLUS Off</p>	<p>DISTRONIC PLUS has been deactivated (▷ page 182).</p> <p>If it was deactivated automatically, a warning tone also sounds.</p>
<p>DISTRONIC PLUS available again</p>	<p>DISTRONIC PLUS is operational again after having been temporarily unavailable. You can now reactivate DISTRONIC PLUS (▷ page 182).</p>

Display messages	Possible causes/consequences and ► Solutions
DISTRONIC PLUS currently unavailable See Owner's Manual	<p>DISTRONIC is deactivated and temporarily inoperative. Possible causes:</p> <ul style="list-style-type: none"> <li>• the DISTRONIC PLUS cover in the radiator grille is dirty.</li> <li>• the function is impaired due to heavy rain or snow.</li> <li>• the sensors in the bumpers are dirty.</li> <li>• the radar sensor system is temporarily inoperative, e.g. due to electromagnetic radiation emitted by nearby TV or radio stations or other sources of electromagnetic radiation.</li> <li>• the system is outside the operating temperature range.</li> <li>• the transfer case is in the <b>LOW RANGE</b> transmission position.</li> <li>• the vehicle is on an uphill or downhill gradient of greater than 22%-25%.</li> <li>• the on-board voltage is too low.</li> </ul> <p>A warning tone also sounds.</p> <p>If the display message does not disappear:</p> <ul style="list-style-type: none"> <li>► Pull over and stop the vehicle safely as soon as possible, paying attention to road and traffic conditions.</li> <li>► Engage the parking brake.</li> <li>► Clean the DISTRONIC PLUS cover in the radiator trim and the bumper (▷ page 294).</li> <li>► Restart the engine.</li> </ul> <p>If the system detects that the sensors are fully operational, the display message disappears.</p> <p>DISTRONIC is operational again.</p>
DISTRONIC PLUS inoperative	<p>DISTRONIC PLUS is faulty.</p> <p>BAS might also have failed.</p> <p>A warning tone also sounds.</p> <ul style="list-style-type: none"> <li>► Visit a qualified specialist workshop.</li> </ul>
DISTRONIC PLUS suspended	<p>You have depressed the accelerator pedal. DISTRONIC PLUS is no longer controlling the speed of the vehicle.</p> <ul style="list-style-type: none"> <li>► Remove your foot from the accelerator pedal.</li> </ul>
DISTRONIC PLUS --- km/h	<p>An activation condition for DISTRONIC PLUS is not fulfilled.</p> <ul style="list-style-type: none"> <li>► Check the activation conditions for DISTRONIC PLUS (▷ page 182).</li> </ul>
DISTRONIC PLUS and SPEEDTRONIC inoperative	<p>DISTRONIC PLUS and SPEEDTRONIC are faulty. A warning tone also sounds.</p> <ul style="list-style-type: none"> <li>► Visit a qualified specialist workshop.</li> </ul>

Display messages	Possible causes/consequences and ► Solutions
Cr. control and SPEEDTRONIC inoperative	SPEEDTRONIC and cruise control are malfunctioning. ► Visit a qualified specialist workshop.
Limit --- km/h	While depressing the accelerator pedal beyond the pressure point (kickdown), SPEEDTRONIC cannot be activated.
Cruise control --- km/h	A condition for activating cruise control has not been met. You have tried to store a speed below 30 km/h, for example. ► If conditions permit, drive faster than 30 km/h and store the speed. ► Check the activation conditions for cruise control (> page 173).
120 km/h Maximum speed exceeded	Only for certain countries: the maximum speed has been exceeded. In addition, the multifunction display shows 120 km/h. ► Drive more slowly.

## Tyres

Display messages	Possible causes/consequences and ► Solutions
Tyre pressure displayed only after driving for a few minutes	The tyre pressure monitor is measuring the tyre pressure. ► Drive on. The tyre pressures appear in the multifunction display after you have been driving for a few minutes.
Tyre pressure monitor inoperative	The tyre pressure monitor is faulty. ► Visit a qualified specialist workshop.
Tyre press. monitor inoperative No wheel sensors	The wheels fitted do not have a suitable tyre pressure sensor. The tyre pressure monitor is deactivated. ► Fit wheels with suitable tyre pressure sensors. The tyre pressure monitor is activated automatically after driving for a few minutes.

Display messages	Possible causes/consequences and ► Solutions
<p>Check tyres</p>	<p>The tyre pressure in one or more tyres has dropped significantly. The wheel position is displayed in the multifunction display. A warning tone also sounds.</p> <p> <b>WARNING</b></p> <p>With tyre pressures which are too low, there is a risk of the following hazards:</p> <ul style="list-style-type: none"> <li>• the tyres may burst, especially as the load and vehicle speed increase.</li> <li>• the tyres may wear excessively and/or unevenly, which may greatly impair tyre traction.</li> <li>• the driving characteristics, as well as steering and braking, may be greatly impaired.</li> </ul> <p>There is a risk of an accident.</p> <ul style="list-style-type: none"> <li>► Stop the vehicle without making any sudden steering or braking manoeuvres. Pay attention to the traffic conditions as you do so.</li> <li>► Secure the vehicle against rolling away (▷ page 163).</li> <li>► If there is a flat tyre, inspect the tyres (▷ page 305).</li> <li>► Check the tyre pressure (▷ page 323).</li> <li>► If necessary, correct the tyre pressure.</li> </ul>
<p>Caution, tyre defect</p>	<p>The tyre pressure in one or more tyres has dropped suddenly. The wheel position is displayed in the multifunction display.</p> <p> <b>WARNING</b></p> <p>If you drive with a flat tyre, there is a risk of the following hazards:</p> <ul style="list-style-type: none"> <li>• A flat tyre affects the ability to steer or brake the vehicle.</li> <li>• You could lose control of the vehicle.</li> <li>• Continued driving with a flat tyre will cause excessive heat build-up and possibly a fire.</li> </ul> <p>There is a risk of an accident.</p> <ul style="list-style-type: none"> <li>► Stop the vehicle without making any sudden steering or braking manoeuvres. Pay attention to the traffic conditions as you do so.</li> <li>► Secure the vehicle against rolling away (▷ page 163).</li> <li>► If there is a flat tyre, inspect the tyres (▷ page 305).</li> </ul>

Display messages	Possible causes/consequences and ► Solutions
Please correct tyre pressure	<p>The tyre pressure is too low in at least one of the tyres, or the tyre pressure difference between the wheels is too great.</p> <ul style="list-style-type: none"> <li>► Check the tyre pressures at the next opportunity (▷ page 323).</li> <li>► If necessary, correct the tyre pressure.</li> <li>► Restart the tyre pressure monitor (▷ page 324).</li> </ul>
Wheel sensor(s) missing	<p>There is no signal from the tyre pressure sensor of one or several wheels. The pressure of the affected tyre is not displayed in the multifunction display.</p> <ul style="list-style-type: none"> <li>► Have the faulty tyre pressure sensor replaced at a qualified specialist workshop.</li> </ul>
Tyre pressure monitor not currently available	<p>Due to a source of radio interference, no signals can be received from the wheel sensors. The tyre pressure monitor is temporarily malfunctioning.</p> <ul style="list-style-type: none"> <li>► Drive on. The tyre pressure monitor restarts automatically as soon as the cause has been rectified.</li> </ul>
 <p>Tyre pressure Caution Tyre malfunction</p>	<p>The tyre pressure in one or more tyres has dropped suddenly. A warning tone also sounds.</p> <p><b>⚠ WARNING</b></p> <p>If you drive with a flat tyre, there is a risk of the following hazards:</p> <ul style="list-style-type: none"> <li>• A flat tyre affects the ability to steer or brake the vehicle.</li> <li>• You could lose control of the vehicle.</li> <li>• Continued driving with a flat tyre will cause excessive heat build-up and possibly a fire. There is a risk of an accident.</li> </ul> <ul style="list-style-type: none"> <li>► Stop the vehicle without making any sudden steering or braking manoeuvres. Pay attention to the traffic conditions as you do so.</li> <li>► Secure the vehicle against rolling away (▷ page 163).</li> <li>► If there is a flat tyre, inspect the tyres (▷ page 305).</li> </ul>

Display messages	Possible causes/consequences and ► Solutions
 Tyre pressure Check tyre(s)	<p>The tyre pressure in one or more tyres has dropped significantly.</p> <p> <b>WARNING</b></p> <p>With tyre pressures which are too low, there is a risk of the following hazards:</p> <ul style="list-style-type: none"> <li>• the tyres may burst, especially as the load and vehicle speed increase.</li> <li>• the tyres may wear excessively and/or unevenly, which may greatly impair tyre traction.</li> <li>• the driving characteristics, as well as steering and braking, may be greatly impaired.</li> </ul> <p>There is a risk of an accident.</p> <ul style="list-style-type: none"> <li>► Stop the vehicle without making any sudden steering or braking manoeuvres. Pay attention to the traffic conditions as you do so.</li> <li>► Secure the vehicle against rolling away (▷ page 163).</li> <li>► If there is a flat tyre, inspect the tyres (▷ page 305).</li> <li>► Check the tyre pressure (▷ page 323).</li> <li>► If necessary, correct the tyre pressure.</li> </ul>
 Tyre pressure Please correct	<p>The tyre pressure is too low in at least one of the tyres, or the tyre pressure difference between the wheels is too great.</p> <ul style="list-style-type: none"> <li>► Check the tyre pressures at the next opportunity (▷ page 323).</li> <li>► If necessary, correct the tyre pressure.</li> </ul>

## Vehicle

Display messages	Possible causes/consequences and ► Solutions
To start the engine, shift to either P or N	<p>You have attempted to start the engine with the transmission in position <b>R</b> or <b>D</b>.</p> <ul style="list-style-type: none"> <li>► Shift the transmission to position <b>P</b> or <b>N</b>.</li> </ul>
Auxiliary battery malfunction	<p>The auxiliary battery for the automatic transmission is no longer being charged.</p> <ul style="list-style-type: none"> <li>► Visit a qualified specialist workshop at the next opportunity.</li> <li>► Until then, set the automatic transmission to position <b>P</b> before you switch off the engine.</li> <li>► Before leaving the vehicle, apply the parking brake.</li> </ul>

Display messages	Possible causes/consequences and ► Solutions
	<p><b>G-Class long-wheelbase version:</b> the tailgate is open.  <b>G-Class Cabriolet:</b> the tailgate is open.</p> <p><b>⚠ WARNING</b></p> <p>When the engine is running, exhaust gases can enter the vehicle interior if the tailgate (G-Class long-wheelbase version and G-Class Cabriolet) is open.</p> <p>There is a risk of poisoning.</p> <p>► Close the tailgate (G-Class long-wheelbase version or G-Class Cabriolet).</p>
	<p>The bonnet is open.  A warning tone also sounds.</p> <p><b>⚠ WARNING</b></p> <p>The open bonnet may then block your view when the vehicle is in motion.</p> <p>There is a risk of an accident.</p> <p>► Pull over and stop the vehicle safely as soon as possible, paying attention to road and traffic conditions.</p> <p>► Secure the vehicle against rolling away (► page 163).</p> <p>► Close the bonnet.</p>
	<p>At least one door is open.  A warning tone also sounds.</p> <p>► Close all doors.</p>
 <p>Rear left seat backrest not locked or Front right seat backrest not locked</p>	<p><b>⚠ WARNING</b></p> <p>The driver's or front-passenger seat backrest is not engaged.</p> <p>► Push the backrest back until it engages.</p>

Display messages	Possible causes/consequences and ► Solutions
 <p>Power steering malfunction See Owner's Manual</p>	<p>The power steering assistance is faulty. A warning tone also sounds.</p> <p> <b>WARNING</b></p> <p>You will need to use more force to steer. There is a risk of an accident.</p> <ul style="list-style-type: none"> <li>► Check whether you are able to apply the extra force required.</li> <li>► <b>If you are able to steer safely:</b> carefully drive on to a qualified specialist workshop.</li> <li>► <b>If you are unable to steer safely:</b> do not drive on. Contact the nearest qualified specialist workshop.</li> </ul>
 <p>inoperative Battery low</p>	<p>You have attempted to switch on the auxiliary heating or to activate a departure time using the on-board computer after operating the auxiliary heating twice.</p> <ul style="list-style-type: none"> <li>► Let the engine run for 10 seconds. The auxiliary heating is operational again.</li> </ul> <p>The on-board voltage is too low. The auxiliary heating has switched itself off or cannot be switched on (► page 126).</p> <ul style="list-style-type: none"> <li>► Drive for a longer distance. The battery is being charged. The auxiliary heating is operational again as soon as the on-board electrical system voltage is sufficient.</li> </ul>
 <p>inoperative Refuel</p>	<p>there is too little fuel in the fuel tank. The auxiliary heating cannot be switched on (► page 126).</p> <ul style="list-style-type: none"> <li>► Refuel at the nearest filling station.</li> </ul>
 <p>inoperative See Owner's Manual</p>	<p>The auxiliary heating has a temporary malfunction or is faulty.</p> <ul style="list-style-type: none"> <li>► When the vehicle is on a level surface and the engine has cooled down, make up to four attempts to switch on the auxiliary heating, waiting several minutes between each attempt (► page 126).</li> <li>► If the auxiliary heating does not switch on, consult a qualified specialist workshop.</li> </ul>

Display messages	Possible causes/consequences and ► Solutions
Telephone No service	Your vehicle is outside the network provider's transmitter/receiver range. ► Wait until the mobile phone operational readiness symbol appears in the multifunction display.
 Top up washer fluid	The washer fluid level in the washer fluid reservoir has dropped below the minimum. ► Top up the washer fluid (▷ page 290).

## Key

Display messages	Possible causes/consequences and ► Solutions
 Key does not belong to vehicle	You have put the wrong key in the ignition lock. ► Use the correct key.
 Replace key	The key needs to be replaced. ► Visit a qualified specialist workshop.

## Warning and indicator lamps in the instrument cluster

## Warning and indicator lamps overview

	Dipped-beam headlamps (▷ page 105)		SRS (▷ page 259)
	Side lamps (▷ page 105)		Engine diagnostics (▷ page 259)
	Turn signals (▷ page 108)		Reserve fuel (▷ page 260)
	Main-beam headlamps (▷ page 109)		Coolant (▷ page 260)
	Foglamps (▷ page 106)		Distance warning signal (▷ page 262)
	Rear fog lamp (▷ page 107)		Diesel engine: preglow (▷ page 144)
	Seat belts (▷ page 252)		Tyre pressure monitor (▷ page 263)
	Brakes (yellow) (▷ page 253)		
	Brakes (red) (▷ page 253)		
	ABS (▷ page 254)		
	ESP® (▷ page 256)		
	ESP® OFF (▷ page 256)		

## Safety

## Seat belts

Problem	Possible causes/consequences and ► Solutions
 <p><b>Only for certain countries:</b> the red seat belt warning lamp lights up for six seconds after the engine starts.</p>	<p>The seat belt warning lamp reminds the driver and front passenger to fasten their seat belts.</p> <p>► Fasten your seat belt (▷ page 44).</p>
 <p><b>Only for certain countries:</b> the red seat belt warning lamp lights up after the engine starts. In addition, a warning tone sounds for up to six seconds.</p>	<p>The driver's seat belt is not fastened.</p> <p>► Fasten your seat belt (▷ page 44). The warning tone ceases.</p>
 <p>The red seat belt warning lamp lights up after the engine starts, as soon as the driver's or the front-passenger door is closed.</p>	<p>The driver or front passenger has not fastened their seat belt.</p> <p>► Fasten your seat belt (▷ page 44). The warning lamp goes out.</p> <p>There are objects on the front-passenger seat.</p> <p>► Remove the objects from the front-passenger seat and stow them in a secure place. The warning lamp goes out.</p>
 <p>The red seat belt warning lamp flashes and an intermittent audible warning sounds.</p>	<p>The driver or front passenger has not fastened their seat belt. At the same time, you are driving faster than 25 km/h or have briefly driven faster than 25 km/h.</p> <p>► Fasten your seat belt (▷ page 44). The warning lamp goes out and the intermittent warning tone ceases.</p> <p>There are objects on the front-passenger seat. At the same time, you are driving faster than 25 km/h or have briefly driven faster than 25 km/h.</p> <p>► Remove the objects from the front-passenger seat and stow them in a secure place. The warning lamp goes out and the intermittent warning tone ceases.</p>

## Safety systems

Problem	Possible causes/consequences and ► Solutions
 <p>The red brake system warning lamp comes on while the engine is running.</p>	<p> <b>WARNING</b></p> <p>The brake system is malfunctioning and the braking characteristics may be affected.</p> <p>There is a risk of an accident.</p> <ul style="list-style-type: none"> <li>► If the multifunction display shows a display message, please observe this.</li> <li>► Drive on carefully.</li> <li>► Visit a qualified specialist workshop.</li> </ul>
 <p>The yellow brake system warning lamp lights up while the engine is running. A warning tone also sounds.</p>	<p> <b>WARNING</b></p> <p>The brake boosting effect is malfunctioning and the braking characteristics may be affected.</p> <p>There is a risk of an accident.</p> <ul style="list-style-type: none"> <li>► Pull over and stop the vehicle safely as soon as possible, paying attention to road and traffic conditions. Do not continue driving under any circumstances.</li> <li>► Secure the vehicle against rolling away (► page 163).</li> <li>► Consult a qualified specialist workshop.</li> <li>► Observe the additional display messages in the multifunction display.</li> </ul>
 <p>The yellow brake system warning lamp lights up while the engine is running. A warning tone also sounds.</p>	<p>There is insufficient brake fluid in the fluid reservoir.</p> <p> <b>WARNING</b></p> <p>The braking efficiency may be impaired.</p> <p>There is a risk of an accident.</p> <ul style="list-style-type: none"> <li>► Pull over and stop the vehicle safely as soon as possible, paying attention to road and traffic conditions. Do not continue driving under any circumstances.</li> <li>► Secure the vehicle against rolling away (► page 163).</li> <li>► Do not top up the brake fluid. Topping up will not rectify the fault.</li> <li>► Consult a qualified specialist workshop.</li> <li>► Observe the additional display messages in the multifunction display.</li> </ul>

Problem	Possible causes/consequences and ► Solutions
 <p>The red ABS warning lamp is lit while the engine is running.</p>	<p>ABS (Anti-lock Brake System) has been deactivated due to a fault. BAS (Brake Assist), ESP® (Electronic Stability Program), the HOLD function, hill start assist, the adaptive brake lights and ESP® trailer stabilisation, for example, are therefore also deactivated.</p> <p> <b>WARNING</b></p> <p>The brake system continues to function normally, but without the functions listed above. The wheels could therefore lock if you brake hard, for example.</p> <p>The steerability and braking characteristics may be severely affected. The braking distance in an emergency braking situation can increase.</p> <p>If ESP® is not operational, ESP® is unable to stabilise the vehicle. The danger of skidding and having an accident increases.</p> <ul style="list-style-type: none"> <li>► Observe the additional display messages in the multifunction display.</li> <li>► Drive on carefully.</li> <li>► Visit a qualified specialist workshop.</li> </ul> <p>If the ABS control unit is faulty, there is also a possibility that other systems, such as the navigation system or the automatic transmission, will not be available.</p>

Problem	Possible causes/consequences and ► Solutions
 <p>The red ABS warning lamp is lit while the engine is running.</p>	<p>ABS is temporarily unavailable. BAS, ESP®, EBD (electronic brake force distribution), the HOLD function, hill start assist, ESP® trailer stabilisation and the adaptive brake lights, for example, are therefore also deactivated.</p> <p>Possible causes:</p> <ul style="list-style-type: none"> <li>• Self-diagnosis is not yet complete.</li> <li>• The on-board voltage may be insufficient.</li> </ul> <p> <b>WARNING</b></p> <p>The brake system continues to function normally, but without the functions listed above. The front and rear wheels could therefore lock if you brake hard, for example.</p> <p>The steerability and braking characteristics may be severely affected. The braking distance in an emergency braking situation can increase.</p> <p>If ESP® is not operational, ESP® is unable to stabilise the vehicle. There is a risk of an accident.</p> <ul style="list-style-type: none"> <li>► Carefully drive on a suitable stretch of road making slight steering movements at a speed above 20 km/h. The functions mentioned above are available again when the warning lamp goes out.</li> </ul> <p>If the warning lamp is still on:</p> <ul style="list-style-type: none"> <li>► Observe the additional display messages in the multifunction display.</li> <li>► Drive on carefully.</li> <li>► Visit a qualified specialist workshop.</li> </ul>

Problem	Possible causes/consequences and ► Solutions
 <p>The red ABS warning lamp is lit while the engine is running. A warning tone also sounds.</p>	<p>EBD is faulty. Therefore, ABS, BAS, ESP<sup>®</sup>, the HOLD function, hill start assist, the adaptive brake lights and ESP<sup>®</sup> trailer stabilisation are also not available, for example.</p> <p> <b>WARNING</b></p> <p>The brake system continues to function normally, but without the functions listed above. The front and rear wheels could therefore lock if you brake hard, for example.</p> <p>The steerability and braking characteristics may be severely affected. The braking distance in an emergency braking situation can increase.</p> <p>If ESP<sup>®</sup> is not operational, ESP<sup>®</sup> is unable to stabilise the vehicle. The danger of skidding and having an accident increases.</p> <ul style="list-style-type: none"> <li>► Observe the additional display messages in the multifunction display.</li> <li>► Drive on carefully.</li> <li>► Visit a qualified specialist workshop.</li> </ul>
 <p>The red ABS warning lamp is lit while the engine is running.</p>	<p>You have engaged the differential locks. ABS is deactivated.</p> <ul style="list-style-type: none"> <li>► Disengage the differential locks. Subsequently ABS is reactivated.</li> </ul>
   <p>The yellow brake warning lamp, the yellow ESP<sup>®</sup> and ESP<sup>®</sup> OFF warning lamps and the yellow ABS warning lamp are lit while the engine is running.</p>	<p>ABS and ESP<sup>®</sup> are malfunctioning. Therefore, BAS, EBD, the HOLD function, hill start assist, the adaptive brake lights and ESP<sup>®</sup> trailer stabilisation, for example, are also not available.</p> <p> <b>WARNING</b></p> <p>The brake system continues to function normally, but without the functions listed above. The front and rear wheels could therefore lock if you brake hard, for example.</p> <p>The steerability and braking characteristics may be severely affected. The braking distance in an emergency braking situation can increase.</p> <p>If ESP<sup>®</sup> is not operational, ESP<sup>®</sup> is unable to stabilise the vehicle. The danger of skidding and having an accident increases.</p> <ul style="list-style-type: none"> <li>► Observe the additional display messages in the multifunction display.</li> <li>► Drive on carefully.</li> <li>► Visit a qualified specialist workshop.</li> </ul>

Problem	Possible causes/consequences and ► Solutions
 <p>The yellow ESP<sup>®</sup> warning lamp flashes while the vehicle is in motion.</p>	<p>ESP<sup>®</sup> or traction control has intervened because there is a risk of skidding or at least one wheel has started to spin. Cruise control or DISTRONIC PLUS is deactivated.</p> <ul style="list-style-type: none"> <li>► Only depress the accelerator pedal as far as necessary when pulling away.</li> <li>► Accelerate more gently while the vehicle is in motion.</li> <li>► Adapt your driving style to suit the road and weather conditions.</li> <li>► Do not deactivate ESP<sup>®</sup>.</li> </ul> <p>Exceptions: (► page 62)</p>
 <p>The yellow ESP<sup>®</sup> OFF warning lamp is lit while the engine is running.</p>	<p>ESP<sup>®</sup> is deactivated.</p> <p> <b>WARNING</b></p> <p>If ESP<sup>®</sup> is switched off, ESP<sup>®</sup> is unable to stabilise the vehicle. The danger of skidding and having an accident increases.</p> <ul style="list-style-type: none"> <li>► Reactivate ESP<sup>®</sup>.</li> </ul> <p>Exceptions: (► page 62)</p> <ul style="list-style-type: none"> <li>► Adapt your driving style to suit the road and weather conditions.</li> </ul> <p>If ESP<sup>®</sup> cannot be activated:</p> <ul style="list-style-type: none"> <li>► Have ESP<sup>®</sup> checked at a qualified specialist workshop.</li> </ul>
 <p>The yellow ESP<sup>®</sup> and ESP<sup>®</sup> OFF warning lamps are lit while the engine is running.</p>	<p>ESP<sup>®</sup>, BAS, the HOLD function, hill start assist, the adaptive brake lights and ESP<sup>®</sup> trailer stabilisation are not available due to a malfunction.</p> <p> <b>WARNING</b></p> <p>The brake system continues to function normally, but without the functions listed above. The braking distance in an emergency braking situation can thus increase.</p> <p>If ESP<sup>®</sup> is not operational, ESP<sup>®</sup> is unable to stabilise the vehicle. The danger of skidding and having an accident increases.</p> <ul style="list-style-type: none"> <li>► Observe the additional display messages in the multifunction display.</li> <li>► Drive on carefully.</li> <li>► Visit a qualified specialist workshop.</li> </ul>

Problem	Possible causes/consequences and ► Solutions
 <p>The yellow ESP<sup>®</sup> and ESP<sup>®</sup> OFF warning lamps are lit while the engine is running.</p>	<p>ESP<sup>®</sup>, BAS, the HOLD function, hill start assist and ESP<sup>®</sup> trailer stabilisation are temporarily unavailable.            BAS and the adaptive brake lights may also have failed.            Self-diagnosis is not yet complete.</p> <p> <b>WARNING</b></p> <p>The brake system continues to function normally, but without the functions listed above.            The braking distance in an emergency braking situation can thus increase.            If ESP<sup>®</sup> is not operational, ESP<sup>®</sup> is unable to stabilise the vehicle.            The danger of skidding and having an accident increases.</p> <p>► Carefully drive on a suitable stretch of road making slight steering movements at a speed above 20 km/h.            The functions mentioned above are available again when the warning lamp goes out.</p> <p>If the warning lamp is still on:</p> <ul style="list-style-type: none"> <li>► Observe the additional display messages in the multifunction display.</li> <li>► Drive on carefully.</li> <li>► Visit a qualified specialist workshop.</li> </ul>
 <p>The yellow ESP<sup>®</sup> OFF warning lamp is lit while the engine is running.</p>	<p>You have engaged the differential locks. ABS, ESP<sup>®</sup>, 4ETS and BAS have been deactivated.</p> <ul style="list-style-type: none"> <li>► Disengage the differential locks.            ESP<sup>®</sup>, 4ETS and BAS are subsequently reactivated.</li> <li>► Observe the additional display messages in the multifunction display.</li> </ul>

Problem	Possible causes/consequences and ► Solutions
 <p>The yellow parking brake warning lamp comes on while the vehicle is moving. A warning tone also sounds.</p>	<p>You are driving with the parking brake applied.</p> <ul style="list-style-type: none"> <li>► Release the parking brake. The warning lamp goes out and the warning tone ceases.</li> </ul>
 <p>The red SRS warning lamp is lit while the engine is running.</p>	<p>There is a malfunction in the SRS (Supplemental Restraint System).</p> <p> <b>WARNING</b></p> <p>The airbags or belt tensioners may either be triggered unintentionally or, in the event of an accident, may not be triggered. This poses an increased risk of injury.</p> <ul style="list-style-type: none"> <li>► Drive on carefully.</li> <li>► Have SRS checked at a qualified specialist workshop immediately.</li> </ul> <p>For further information about the Supplemental Restraint System, see (► page 39).</p>

## Engine

Problem	Possible causes/consequences and ► Solutions
 <p>The yellow engine diagnostics warning lamp lights up while the engine is running.</p>	<p>There may be a fault, for example:</p> <ul style="list-style-type: none"> <li>• in the engine management</li> <li>• in the fuel injection system</li> <li>• in the exhaust system</li> <li>• in the ignition system (for vehicles with petrol engines)</li> <li>• in the fuel system</li> </ul> <p>The emission limit values may be exceeded and the engine may be running in emergency mode.</p> <ul style="list-style-type: none"> <li>► Have the vehicle checked as soon as possible at a qualified specialist workshop.</li> </ul>
 <p>The yellow engine diagnostics warning lamp lights up while the engine is running.</p>	<p>Vehicles with a diesel engine: the fuel tank has been run dry (► page 159).</p> <ul style="list-style-type: none"> <li>► Start the engine three to four times after refuelling. If the yellow engine diagnostics warning lamp goes out, emergency running mode is cancelled. The vehicle need not be checked.</li> </ul>

Problem	Possible causes/consequences and ► Solutions
 <p>The yellow reserve fuel warning lamp lights up while the engine is running.</p>	<p>The fuel level has dropped into the reserve range.            Operation of the auxiliary heating is deactivated when the fuel level drops into the reserve range.</p> <ul style="list-style-type: none"> <li>► Refuel at the nearest filling station.</li> </ul>
 <p>On diesel engine vehicles, the preglow indicator lamp does not light up when the key is in position  <b>2</b>(▷ page 143).</p>	<p>The preglow system is malfunctioning.</p> <ul style="list-style-type: none"> <li>► Visit a qualified specialist workshop immediately.</li> </ul>
 <p>The red coolant warning lamp lights up while the engine is running and the coolant temperature gauge is at the start of the scale.</p>	<p>The temperature sensor for the coolant temperature gauge is faulty.            The coolant temperature is no longer being monitored. There is a risk of engine damage if the coolant temperature is too high.</p> <ul style="list-style-type: none"> <li>► Stop the vehicle immediately, paying attention to road and traffic conditions, and switch off the engine. Do not continue driving under any circumstances.</li> <li>► Engage the parking brake.</li> <li>► Consult a qualified specialist workshop.</li> </ul>

Problem	Possible causes/consequences and ► Solutions
 <p>The red coolant warning lamp comes on while the engine is running.</p>	<p>The coolant level is too low.</p> <p>If the coolant level is correct, the airflow to the engine radiator may be blocked or the electric engine radiator fan may be malfunctioning.</p> <p>The coolant is too hot and the engine is no longer being cooled sufficiently.</p> <ul style="list-style-type: none"> <li>► Observe the additional display messages in the multifunction display.</li> <li>► Stop the vehicle immediately, paying attention to road and traffic conditions, and switch off the engine.</li> <li>► Engage the parking brake.</li> <li>► Leave the vehicle and keep a safe distance from the vehicle until the engine has cooled down.</li> <li>► Check the coolant level and top up the coolant, observing the warning notes (► page 289).</li> <li>► If you have to top up the coolant frequently, have the engine cooling system checked.</li> <li>► Make sure that the air supply to the engine radiator is not blocked, e.g. by frozen slush.</li> <li>► Do not start the engine again until the coolant temperature is below 120 °C. The engine may otherwise be damaged.</li> <li>► Drive to the nearest qualified specialist workshop.</li> <li>► Avoid subjecting the engine to heavy loads, e.g. driving in mountainous terrain, and stop-start driving.</li> </ul>
 <p>The red coolant warning lamp comes on while the engine is running. A warning tone also sounds.</p>	<p>The coolant temperature has exceeded 120 °C. The airflow to the engine radiator may be blocked or the coolant level may be too low.</p> <p> <b>WARNING</b></p> <p>The engine is not being cooled sufficiently and may be damaged. Never drive with an overheated engine. Driving when your engine is overheated can cause some fluids which may have leaked into the engine compartment to catch fire.</p> <p>Steam from an overheated engine can cause serious burns which can occur just by opening the bonnet.</p> <p>There is a risk of injury.</p> <ul style="list-style-type: none"> <li>► Observe the additional display messages in the multifunction display.</li> <li>► Stop the vehicle immediately, paying attention to road and traffic conditions, and switch off the engine.</li> <li>► Secure the vehicle against rolling away (► page 163).</li> </ul>

Problem	Possible causes/consequences and ► Solutions
	<ul style="list-style-type: none"> <li>► Leave the vehicle and keep a safe distance from the vehicle until the engine has cooled down.</li> <li>► Check the coolant level and top up the coolant, observing the warning notes (▷ page 289).</li> <li>► If you have to top up the coolant frequently, have the engine cooling system checked.</li> <li>► Make sure that the air supply to the engine radiator is not blocked, e.g. by frozen slush.</li> <li>► If the coolant temperature is below 120 °C, you can continue driving to the nearest qualified specialist workshop.</li> <li>► Avoid subjecting the engine to heavy loads, e.g. driving in mountainous terrain and stop-start driving.</li> </ul>

### Driving systems

Problem	Possible causes/consequences and ► Solutions
 <p>The red distance warning lamp lights up while the vehicle is in motion.</p>	<p>The distance to the vehicle in front is too small for the speed selected.</p> <ul style="list-style-type: none"> <li>► Increase the distance.</li> </ul>
 <p>The red distance warning lamp lights up while the vehicle is in motion. A warning tone also sounds.</p>	<p>You are approaching a vehicle or a stationary obstacle in your line of travel at too high a speed.</p> <ul style="list-style-type: none"> <li>► Be prepared to brake immediately.</li> <li>► Pay careful attention to the traffic situation. You may have to brake or take evasive action.</li> </ul> <p>Further information on DISTRONIC PLUS (▷ page 182).</p>

Tyres	
Problem	Possible causes/consequences and ► Solutions
 <p>The yellow tyre pressure monitor warning lamp is on.</p>	<p>The tyre pressure monitor has detected a loss of pressure in at least one of the tyres.</p> <p> <b>WARNING</b></p> <p>With tyre pressures which are too low, there is a risk of the following hazards:</p> <ul style="list-style-type: none"> <li>• the tyres may burst, especially as the load and vehicle speed increase.</li> <li>• the tyres may wear excessively and/or unevenly, which may greatly impair tyre traction.</li> <li>• the driving characteristics, as well as steering and braking, may be greatly impaired.</li> </ul> <p>There is a risk of an accident.</p> <ul style="list-style-type: none"> <li>► Stop the vehicle without making any sudden steering or braking manoeuvres. Pay attention to the traffic conditions as you do so.</li> <li>► Secure the vehicle against rolling away (▷ page 163).</li> <li>► Observe the additional display messages in the multifunction display.</li> <li>► If there is a flat tyre, inspect the tyres (▷ page 305).</li> <li>► Check the tyre pressure (▷ page 323).</li> <li>► If necessary, correct the tyre pressure.</li> </ul>



Useful information .....	266
Loading guidelines .....	266
Stowage areas .....	267
Features .....	275

## Useful information

- i** This Owner's Manual describes all models, series and optional equipment for your vehicle that were available at the time of going to press. Country-specific differences are possible. Note that your vehicle may not be fitted with all features described. This is also the case for systems and functions relevant to safety.
- i** Read the information on qualified specialist workshops: (▷ page 22).

## Loading guidelines

**⚠ WARNING**

Secure and position the load as described in the loading guidelines.

Otherwise, vehicle occupants could be injured by the load being thrown around in the event of sharp braking, a sudden change in direction or an accident. This also applies to seats which have been removed.

You will find further information in the "Securing a load" section.

Even if you follow all the loading guidelines, the load will increase the risk of injury in the event of an accident.

**⚠ WARNING**

Keep the boot lid/tailgate closed when the engine is running. Otherwise, you could be poisoned by exhaust fumes entering the vehicle.



The handling characteristics of a laden vehicle are dependent on the distribution of the load within the vehicle. You should therefore load your vehicle as shown in the illustrations. Observe the following notes when transporting a load:

- when transporting a load, never exceed the maximum permissible gross vehicle weight or the permissible axle loads for the vehicle (including occupants).
- position heavy loads as far forwards as possible and as low down in the load compartment as possible.
- the load must not protrude above the upper edge of the seat backrests.
- always place the load against the front or rear seat backrests.
- always place the load behind unoccupied seats if possible.
- if possible, always transport the load in the load compartment with the seat backrests folded up and engaged.

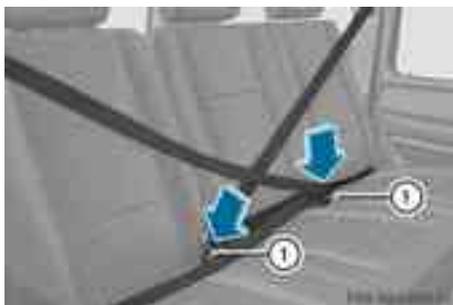

If the rear bench seat is not occupied:

- ▶ insert the belt tongue on the outer seat belts into the buckle of opposite seat belt ①.
- ▶ secure the load with sufficiently strong and wear-resistant lashing material.
- ▶ pad sharp edges for protection.

**i** Lashing material that has been checked in accordance with applicable standards is available at any qualified specialist workshop.

## Stowage areas

### Stowage compartments

#### Important safety notes

##### WARNING

The stowage compartments must be closed when items are stored in them. Luggage nets are not designed to secure heavy items of luggage.

You or other vehicle occupants could be injured by objects being thrown around if you:

- brake sharply
- change direction suddenly
- are involved in an accident

Sharp-edged and fragile objects must not be placed in the luggage net.

Do not place hard objects in the map pockets. Objects must not protrude from the map pockets.

## Front stowage compartments

### Glove compartment



▶ **To open:** pull handle ① and open glove compartment flap ②.

▶ **To close:** fold glove compartment flap ② upwards until it engages.

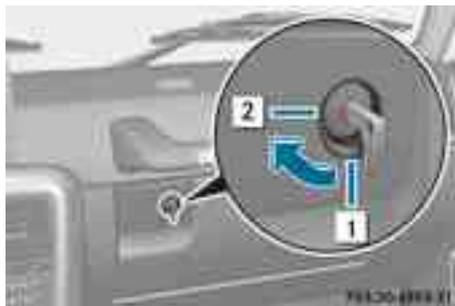

① Glove compartment unlocked

② Glove compartment locked

▶ **To lock:** (▷ page 70) insert the emergency key element into the lock and turn it 90° clockwise to position ②.

▶ **To unlock:** (▷ page 70) insert the emergency key element into the lock and turn it 90° anti-clockwise to position ①.

**i** The glove compartment can only be locked and unlocked using the emergency key element.

**i** The glove compartment is illuminated when open, provided that the key is in position ① or ② in the ignition lock.

### Stowage compartment/telephone compartment under the armrest/in the centre console



- ① Small stowage compartment
- ② Release button for the armrest

Stowage compartment/telephone compartment under the armrest

- ▶ **To open:** press button ②.
- ▶ Fold up armrest.
- ❗ In the stowage compartment, there is a stowage tray and a mobile phone bracket.
- ▶ **To close:** fold the armrest down. The armrest engages audibly.

### Rear stowage compartments

#### Map pockets



- ① Map pockets

### Stowage nets

#### ⚠ WARNING

Only place lightweight items in the stowage net. Do not use it to transport heavy, bulky, sharp-edged or fragile objects. In the event of an accident, the stowage net will not secure the transported goods sufficiently.

The stowage net is in the front-passenger footwell.

### Enlarging the luggage compartment

#### Important safety notes

#### ⚠ WARNING

Do not carry heavy or hard objects inside the vehicle or in the luggage compartment unless they are secured.

Otherwise, you and other vehicle occupants could be injured by objects being thrown around the vehicle in the event of sharp braking, a sudden change in direction or an accident.

When using the luggage compartment enlargement, you should always clip in the safety net, if at hand.

#### ⚠ WARNING

Keep the boot lid/tailgate closed when the engine is running. Otherwise, you could be poisoned by exhaust fumes entering the vehicle.

- ❗ Make sure that you remove any containers from the rear-compartment cup holders before folding forward the backrests and seat cushions of the rear bench seat.

**G-Class Cabriolet:** the rear bench seat is split symmetrically.

**G-Class long-wheelbase version:** the rear bench seat is split asymmetrically.

The left-hand and right-hand rear seats can be folded down to increase the load compartment capacity. The following changes are possible:

- fold the seat backrests forward
- fold the rear bench seat down fully.

### Folding the seat backrest forwards



To fold forward the seat backrests, proceed as follows:

- ▶ open the rear doors.  
This allows you better access to release lever ①.
- ▶ Remove the centre head restraint (▷ page 93).
- ▶ Pull catch ① in the direction of the arrow.  
The corresponding rear seat backrest is not engaged.
- ▶ Fold the backrest forwards.  
The rear seat backrest engages audibly.



② Backrest folded forward

### Folding back the seat backrest

**!** Make sure that the seat belt does not become trapped when folding the rear seat backrest back. Otherwise, it could be damaged.

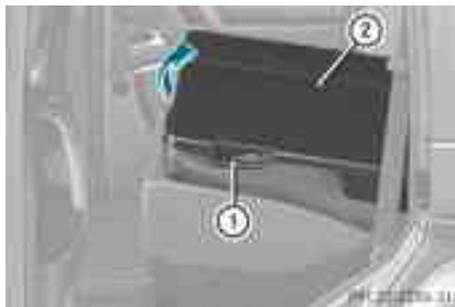

- ▶ Pull release lever ①.  
The corresponding seat backrest is released.
- ▶ Fold backrest ② backwards in the direction of the arrow.  
The seat catch engages audibly.
- ▶ Fit the head restraint (▷ page 93).

### Rear bench seat

#### Seat backrest release lever

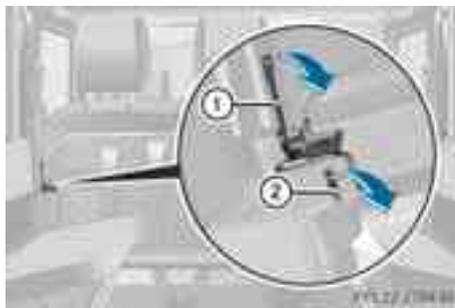

Seat backrest release lever

- ① Long lever
- ② Short lever

**i** G-Class long-wheelbase version: open the rear doors. This allows you better access to the release lever.

- ▶ Remove the head restraints (▷ page 93).
- ▶ Pull short lever ② in the direction of the arrow and hold it.
- ▶ Pull long lever ① in the direction of the arrow and fold the seat backrest forwards.

### Folding the rear bench seat forwards

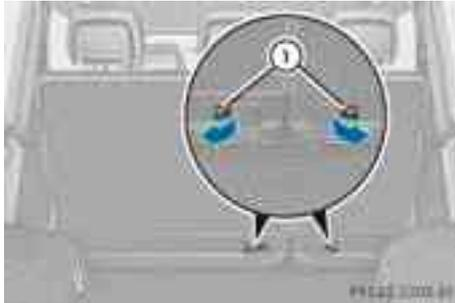

- ▶ Fold rear seat backrest (▷ page 269) forwards.
- ▶ Pull catch ① in the direction of the arrow. The corresponding rear bench seat is released.
- ▶ Fold rear bench seat ② forwards.



② Rear bench seat folded forward

### Folding the rear bench seat into an upright position

#### WARNING

Make sure that the rear bench seat and seat backrests are correctly engaged in position.

If the seat backrests or rear bench seat are not fully engaged and the following occurs:

- sharp braking
- a sudden change of direction
- an accident

the seat backrests or rear bench seat may fold forwards and instead of being restrained by the seats as intended you could be injured by them. Occupants could then also be injured in the event of an accident, e.g. by objects being thrown forwards from the luggage compartment.

- ▶ Fold the rear bench seat back. The seat catch engages audibly.
- ▶ Fold the backrest backwards (▷ page 269).
- ▶ Fit the head restraints (▷ page 93).

### Securing a load

#### Important safety notes

#### WARNING

Distribute the load on the lashing eyelets evenly.

Otherwise, vehicle occupants could be injured by objects being thrown around if you:

- brake sharply
- change direction suddenly
- are involved in an accident

Please observe the loading guidelines.

Observe the following notes on securing loads:

- secure the load using the lashing eyelets.
- do not use elastic straps or nets to secure a load, as these are only intended as an anti-slip protection for light loads.
- if you are using tensioning straps, only use tensioning straps with a minimum permissible tensile strength of  $F_{zul} = 600 \text{ daN}$  and a percentage elongation of approximately 7%.

- do not route lashing materials across sharp edges or corners.
- Pad sharp edges for protection.
- only use lashing material that has been checked in accordance with applicable standards, e.g. lashing nets or lashing straps.
- fill the spaces between the load and the load compartment walls and the wheel mountings in a form-locking way. Only use dimensionally stable transportation aids for this, such as chocks, wooden fixings or padding.

### Lashing eyelets in the load compartment



**G-Class long-wheelbase version:** there are four lashing eyelets ① mounted at the sides in the load compartment.



G-Class Cabriolet with the rear bench seat folded forwards

### Luggage compartment cover

#### Important safety notes

##### **WARNING**

The luggage compartment cover is not a restraint system. Secure the load under the luggage compartment cover by suitable means. Make sure that the luggage compartment cover is engaged securely. If luggage is not sufficiently secured, it can be thrown over the backrest into the passenger compartment, for instance during heavy braking, sudden changes of direction or in the event of an accident. You could cause an accident or cause injury to yourself and others.

- ❗ When loading the vehicle, make sure that you do not stack the load in the luggage compartment higher than the lower edge of the side windows. Do not place heavy objects on top of the luggage compartment cover.

The luggage compartment cover is located behind the rear bench seat backrest.

### Opening and closing the luggage compartment cover



**i** Luggage compartment cover ① consists of two roller blinds. You can cover the entire luggage compartment even if the rear seat backrest is folded down.

- ▶ **To open:** pull luggage compartment cover ① back and clip it into the retainers on the left and right of the rear door.
- ▶ **To close:** unclip luggage compartment cover ① and guide it forwards until it is completely rolled up.

### Fitting/removing the luggage compartment cover



- ▶ **To remove:** make sure that luggage compartment cover ② is rolled up.
- ▶ Slide catches ① on the left-hand and right-hand sides of luggage compartment cover ② towards the centre of the vehicle.
- ▶ Swing luggage compartment cover ② up and out.

- ▶ **To fit:** slide catches ① towards the centre of the vehicle.
- ▶ Insert luggage compartment cover ② into the recesses in the side trim.
- ▶ Push down the right-hand and left-hand sides of luggage compartment cover ② until it engages.
- ▶ Slide catches ① in the direction of the side trim.

### Safety net

#### Important safety notes

##### WARNING

You must make sure that the safety net is correctly secured at the top and bottom. Do not use a damaged safety net. The safety net cannot restrain heavy loads. For this reason, you should always secure the load.

Otherwise, objects that have not been secured sufficiently might be thrown around if you brake suddenly, change direction suddenly or are involved in an accident, and could cause you an injury.

#### Safety net without luggage compartment enlargement

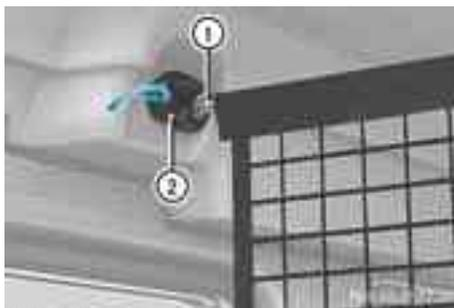

- ▶ Open the rear door.  
This allows you to hook in the safety net more easily.
- ▶ Fold the rear bench seat forward, without folding the seat backrest forward beforehand (▷ page 270).
- ▶ Hook safety net ① into retainers ② on both sides.



- ▶ Tensioning buckles ③ of tensioning straps ④ must point in the direction of travel.
- ▶ Tensioning straps ④ can be set to the length for lashing eyelets ⑥ using tensioning buckles ③.



- ▶ Engage hooks ⑤ in lashing eyelets ⑥.
- ▶ Pull the loose ends of tensioning straps ④ to tension safety net.

- ▶ Fold the rear bench seat forward into an upright position (▷ page 270).  
The safety net is tensioned by the rear bench seat.
- ▶ After driving a short distance, check the tension of the safety net and retighten it if necessary.



Fitted safety net

### Safety net with luggage compartment enlargement

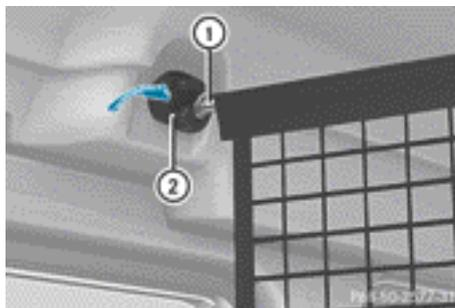

- ▶ Fold rear bench seat forwards (▷ page 270).
- ▶ Hook safety net ① into retainers ② on both sides.

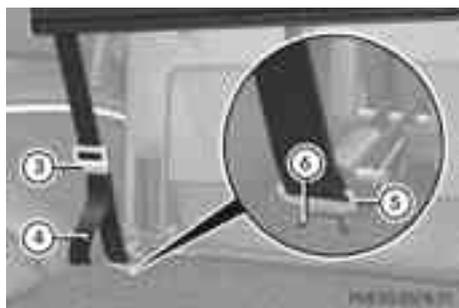

- ③ Tensioning buckle
- ④ Tensioning strap
- ⑤ Hook
- ⑥ Lashing eyelet

- ▶ Tensioning straps ④ can be set to the length for lashing eyelets ⑥ using tensioning buckles ③.
- Tensioning buckles ③ of tensioning straps ④ must point in the direction of the luggage compartment.
- ▶ Engage hooks ⑤ in lashing eyelets ⑥.
- ▶ Pull the loose ends of tensioning straps ④ tight, until tension safety net is adequately tensioned.
- ▶ After driving a short distance, check the tension of the safety net and retighten it if necessary.



Fitted safety net

## Releasing the safety net

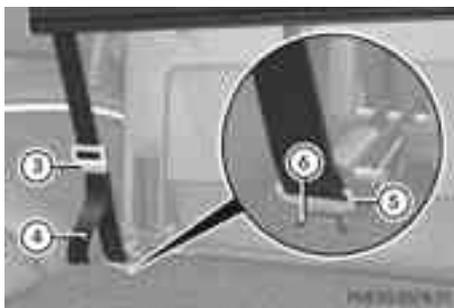

- ③ Tensioning buckle
- ④ Tensioning strap
- ⑤ Hook
- ⑥ Lashing eyelet

- ▶ Lift tensioning buckles ③ into the horizontal position.
- Tensioning straps ④ slacken off.
- ▶ Unclip hook ⑤ from lashing eyelets ⑥.

## Detaching the safety net

- ▶ Detach safety net ① from holder ②.

## Storing the safety net

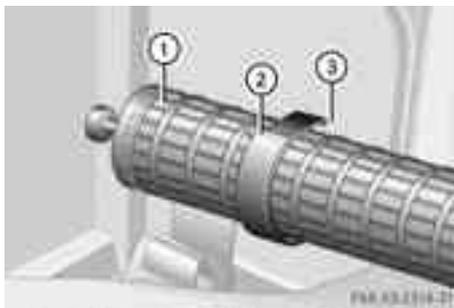

- ▶ Roll up safety net ① and secure it using Velcro strips ②.
- ▶ Place safety net ① behind the rear bench seat in holder ③.

## Roof carrier

### WARNING

An incorrectly secured roof carrier, ski rack or load could become detached from the vehicle. These objects may then be thrown around and can injure you or others or cause an accident. Follow the roof carrier/ski rack manufacturer's installation instructions and special instructions for use.

The roof load raises the vehicle's centre of gravity, thereby affecting vehicle handling. Always observe the maximum roof load (see the "Technical data" section). Always adapt your driving style to the prevailing road, traffic and weather conditions and drive with particular care if the roof is laden.

- !** Mercedes-Benz recommends that you only use roof carriers that have been tested and approved for Mercedes-Benz vehicles. This helps to prevent damage to the vehicle.

Position the load on the roof carrier in such a way that the vehicle will not sustain damage even when it is in motion.

Make sure that the sliding sunroof can be fully raised, depending on the vehicle's equipment.

- ▶ Follow the manufacturer's installation instructions when fitting the roof carrier.

## Features

### Cup holders

#### Important safety notes

### WARNING

If you are transporting objects in the stowage compartments, the stowage compartments must remain closed while the vehicle is in motion. Otherwise, vehicle occupants could be injured by objects being thrown around if you:

- brake sharply
- change direction suddenly
- are involved in an accident

Only use the cup holders for containers of a suitable size and which have lids. The drinks could otherwise spill.

Cup holders should not be used for hot drinks. You may otherwise scald yourself.

#### Cup holders in the glove compartment



- ▶ **To open:** fold down the glove compartment cover.

- i** Locking/unlocking the glove compartment (▶ page 267).

#### Cup holder on the centre console



- ▶ Fold cup holder ① all the way up.

#### Cup holders in the rear compartment

- !** Make sure that you remove any containers from the rear-compartment cup holders

before folding forward the backrests and seat cushions of the rear bench seat.



- ① Cup holders

### Sun visors

#### Sun visor overview

#### WARNING

Keep the vanity mirrors in the sun visors covered while driving. You could otherwise be dazzled, which may impair your view of traffic conditions and as a result could cause an accident.

#### Vanity mirror in the sun visor

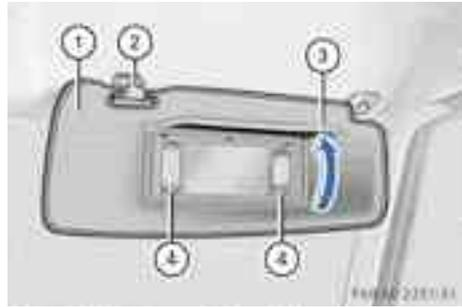

- ① Sun visor
- ② Bracket
- ③ Mirror cover
- ④ Mirror light

Mirror lights ④ will only function if sun visor ① is clipped into bracket ②.

- ▶ Fold down sun visor ①.
- ▶ Fold up mirror cover ③.
- Mirror lights ④ are switched on automatically.

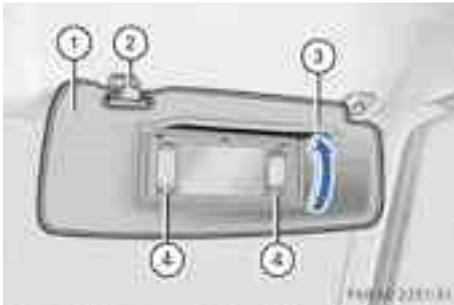

- ① Sun visor
- ② Bracket
- ③ Mirror cover
- ④ Mirror light

#### Glare from the side

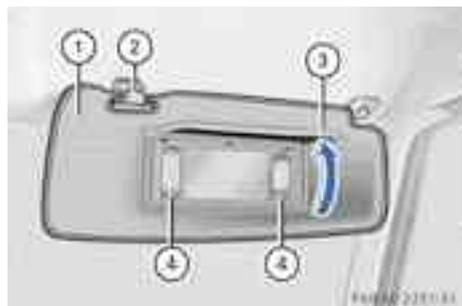

- ① Sun visor
- ② Bracket
- ③ Mirror cover
- ④ Mirror light

- ▶ Fold down sun visor ①.
- ▶ Pull sun visor ① from bracket ②.
- ▶ Swing sun visor ① to the side.

## Stowage compartment/ashtray

### Stowage compartment/ashtray in the centre console

#### WARNING

Make sure that the engine has been switched off and that the parking brake is applied so that the vehicle cannot pull away unintentionally.

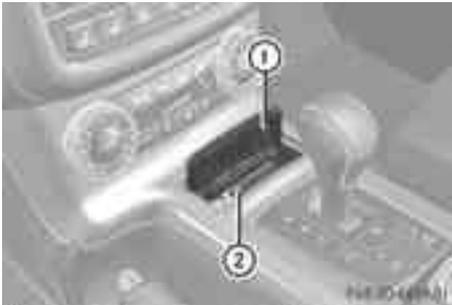

① Cover

② Insert

**i** On new vehicles, insert ② is stored in the glove compartment. Fit the insert before using the ashtray.

► **To open:** press cover ① and then release it.

The ashtray opens.

► **To remove the insert:** make sure that the engine is switched off and that the parking brake has been applied to secure the vehicle against rolling away.

► Move the selector lever to **N**.

► Press down cover ①.  
Insert ② is released.

► Pull insert ② upwards and remove it.

► **To fit the insert:** fit insert ② from above.

► Push insert ② down.  
Insert ② audibly engages.

► **To close:** close cover ① fully.

**i** The ashtray is lit up if the dipped-beam headlamps are on.

### Ashtray in the rear compartment (G-Class long-wheelbase version)



► **To open:** fold cover ② out in the direction of the arrow.

► **To remove the insert:** press retaining lug ① and pull insert ③ upwards and out.

► **To fit the insert:** fit insert ③ from above.

► **To close:** close cover ② fully.

## Cigarette lighter

#### WARNING

Only hold the hot cigarette lighter by its knob. Otherwise, you might burn yourself.

Make sure that children travelling in the vehicle are not able to injure themselves on the hot cigarette lighter or cause a fire with it.



► Press in cigarette lighter ①.

Cigarette lighter ① will pop out automatically when the heating element is red-hot.

- i** You can use the cigarette lighter socket for accessories up to 180 W (> page 278).

### 12 V sockets

#### General notes

- !** If you are simultaneously using all three sockets in the vehicle, make sure that you do not exceed the maximum current draw of 45 A. Otherwise, you will overload the fuses.

The sockets can be used for accessories with a maximum current draw of 180 W (15 A), e.g. lamps or chargers for mobile phones.

If you use the sockets for long periods when the engine is switched off, the battery may discharge.

- Turn the key to position **2** in the ignition lock.

#### Socket in the front-passenger footwell



- Fold out the flap on the socket.
- i** The cigarette lighter socket can be also used (> page 277). It can also be used if the key has been removed from the ignition lock.

#### Socket in the rear compartment



The socket is located on the centre console in the rear compartment.

- Fold out the flap on the socket.

#### Load compartment power socket (G-Class long-wheelbase version)



The socket is located in the luggage compartment on the left-hand-side when viewed in the direction of travel, next to the rear door.

- Fold out the flap on the socket.

### Mobile phone

#### Important safety notes

##### **⚠ WARNING**

Observe the legal requirements of the country in which you are currently driving regarding operating mobile communications equipment in a vehicle.

If it is permitted by law to operate communications equipment while the vehicle is in

motion, you must only do so if the traffic situation permits. Otherwise, you could be distracted from the traffic conditions, cause an accident and injure yourself and others.

Two-way radios and fax equipment used without low-reflection exterior aerials can interfere with the vehicle's electronics and thereby jeopardise the operating safety of the vehicle and your safety. Therefore, you must only use this equipment if it is correctly connected to a separate reflection-free exterior aerial.

### WARNING

Excessive levels of electromagnetic radiation may cause damage to your health and the health of others. Using an exterior aerial takes into account current scientific discussions relating to the possible health risk posed by electromagnetic fields.

Mercedes-Benz recommends the use of an approved exterior aerial. This ensures:

- optimal mobile phone reception quality in the vehicle
- mutual influences between the vehicle electronics and mobile phones are minimised

An exterior aerial has the following advantages:

- it conducts the electromagnetic fields generated by a wireless device to the exterior.
- the field strength in the vehicle interior is lower than in a vehicle that does not have an exterior aerial.

**i** There are various mobile phone brackets that may be fitted in your vehicle; in some cases, these are country-specific. You can obtain these mobile phone brackets from a qualified specialist workshop.

The functions and services available when you use the phone depend on your mobile phone model and service provider.

## Mobile telephone bracket in the stowage space



You can fold the pre-installed bracket up to improve access to the stowage space beneath it.

- ▶ **To fold the bracket up:** press button ①.
- ▶ **To fold the bracket down:** press the bracket down and until it audibly engages.

**i** Depending on the vehicle's equipment, a USB connection, an AUX-IN connection or a Media Interface are fitted in the stowage compartment. A Media Interface is a universal interface for portable audio equipment, e.g. for an iPod® or USB device (see the separate Audio or COMAND APS operating instructions).

## Using a mobile phone

If the mobile phone is inserted in the mobile phone bracket, you can only speak to the person you are calling using the hands-free system.

- ▶ Open the telephone compartment (▷ page 268).
- ▶ Place the mobile phone bracket into the pre-installed bracket; see the separate mobile phone bracket installation instructions.
- ▶ Insert the mobile phone into the mobile phone bracket; see the separate mobile phone bracket installation instructions.

## Operating the mobile phone

You can operate the telephone using the  and  buttons on the multifunction steering wheel. You can operate other mobile phone functions via the on-board computer (> page 218).

When you remove the key from the ignition lock, the mobile phone remains switched on for approximately ten minutes (run-on time). If you make a call during this time, the mobile phone will be switched off approximately ten minutes after you have ended the call.

## Garage door opener

### Important safety notes

You can use the HomeLink® garage door opener integrated into the rear-view mirror to operate up to three different gate/garage door opener systems.

**i** The garage door opener is only available for certain countries. Observe the legal requirements for each individual country.

The HomeLink® garage door opener is compatible with most European garage and gate opener drives. More information on HomeLink® and/or compatible products is available from:

- any Mercedes-Benz Service Centre
- the HomeLink® hotline  
(0) 08000 466 354 65 (free of charge) or  
+49 (0) 6838 907 277 (charges apply)
- on the Internet at:  
<http://www.homelink.com>

## Programming the remote control

### Programming

#### WARNING

Only press the button on the integrated garage door opener if there are no persons or objects present within the sweep of the

garage door. Persons could otherwise be injured as the door moves.

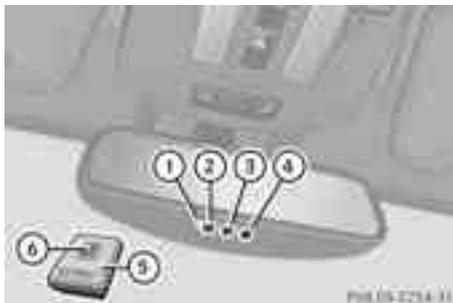

Remote control in the rear-view mirror

- ① Indicator lamp
- ②③④ Transmitter buttons
- ⑤ Garage door remote control
- ⑥ Transmitter button on the garage door remote control

Garage door remote control ⑤ is not part of the garage door opener.

**i** To achieve the best result, insert new batteries in garage door remote control ⑤ of your garage door drive before programming.

- ▶ Delete the memory of the integrated remote control (> page 283) before programming it for the first time.
- ▶ Turn the key to position **2** (> page 143) in the ignition lock.
- ▶ Press and hold transmitter button ②, ③ or ④.

After a short time, indicator lamp ① will start flashing. It flashes about once per second.

**i** Indicator lamp ① flashes immediately the first time that the transmitter button is programmed. If this transmitter button has already been programmed, indicator lamp ① will only start flashing at a rate of once a second after 20 seconds have elapsed.

- ▶ Keep the transmitter button depressed.

- ▶ Point transmitter button ⑥ of garage door remote control ⑤ towards the transmitter buttons on the rear-view mirror at a distance of 5 to 30 cm.

**i** The distance between garage door remote control ⑤ and the integrated garage door opener depends on the system of the garage door drive. Several attempts may be required. You should test every position for at least 20 seconds before trying another position.

- ▶ Keep transmitter button ⑥ on garage door remote control ⑤ pressed until indicator lamp ① starts to flash rapidly. The programming has been successful if indicator lamp ① flashes rapidly.
- ▶ Release transmitter buttons ②, ③ or ④ on the integrated remote control and transmitter button ⑥ on the garage door remote control.

If indicator lamp ① goes out after approximately 20 seconds and has not flashed rapidly:

- ▶ Release transmitter buttons ②, ③ or ④ on the integrated remote control and transmitter button ⑥ on the garage door remote control.
- ▶ Repeat the procedure for the other transmitter buttons. When doing so, vary the distance between the garage door's remote control and the transmitter buttons in the rear-view mirror.

**i** If the garage door system works with a rolling code, you must synchronise the remote control integrated into the rear-view mirror with the garage door system receiver after programming.

You will find further information in the garage door system's operating instructions, e.g. the sections on "Synchronising the transmitter" or "Registering a new transmitter". You can also call the hotline mentioned above.

## Synchronising the rolling code

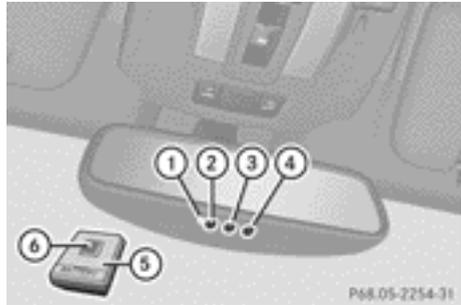

Remote control in the rear-view mirror

- ① Indicator lamp
- ②③④ Transmitter buttons
- ⑤ Garage door remote control
- ⑥ Transmitter button on the garage door remote control

Your vehicle must be within range of the garage door or exterior gate drive. Make sure that neither your vehicle nor any persons/objects are present within the sweep of the door or gate.

Observe the safety notes when performing the rolling code synchronisation (▷ page 280).

- ▶ Turn the key to position 2 (▷ page 143) in the ignition lock.
- ▶ Press the programming button of the door or gate drive (see the door or gate drive operating instructions, e.g. under "Programming of additional remote controls").
- i** Usually, you now have 30 seconds to initiate the next step.
- ▶ Press previously programmed button ②, ③ or ④ of the integrated garage door opener until the door closes. The rolling code synchronisation is then complete.

## Problems when programming

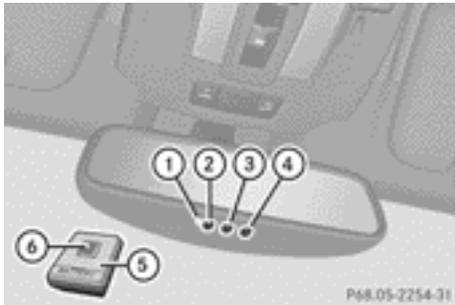

Remote control in the rear-view mirror

- ① Indicator lamp
- ②③④ Transmitter buttons
- ⑤ Garage door remote control
- ⑥ Transmitter button on the garage door remote control

If you have problems when programming the integrated remote control, please note the following:

- check the transmitter frequency of garage door remote control ⑤ (which can usually be found on the back of the remote control).

The integrated remote control is compatible with devices that have units which operate in the frequency range of 280 to 390 MHz.

- Replace the batteries in garage door remote control ⑤. This increases the probability of garage door remote control ⑤ sending a strong and more precise signal to the integrated remote control on the rear-view mirror.
- when programming, hold garage door remote control ⑤ at varying distances and angles from the transmitter button which you are programming. Try various angles at a distance between 5 and 30 cm or at the same angle but at varying distances.
- if there is another garage door remote control for the same device, perform the programming steps again using that garage door opener. Before performing these

steps, make sure that new batteries have been fitted in the garage door remote control.

- Align the aerial cable of the garage door opener unit. This can improve signal reception/transmission.

## Opening or closing the garage door

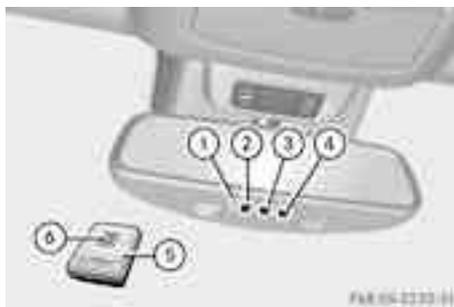

- ① Indicator lamp
- ②③④ Transmitter buttons
- ⑤ Garage door remote control
- ⑥ Transmitter button on the garage door remote control

Once programmed, the integrated remote control will assume the function of the garage door system remote's control. Please also read the operating instructions for the garage door system.

- ▶ Turn the key to position **2** (▷ page 143) in the ignition lock.
- ▶ Press transmitter button ②, ③ or ④ on the integrated remote control in the rear-view mirror that is programmed to operate the garage door.

Garage door system with fixed code: indicator lamp ① lights up continuously.

Garage door system with rolling code: indicator lamp ① flashes briefly and then lights up for approximately two seconds. This is repeated for up to 20 seconds.

- ❗ The transmitter will transmit a signal for as long as the transmitter button is pressed. The transmission will be halted after a maximum of 20 seconds and indi-

cator lamp ① will flash. Press the transmitter button again if necessary.

### Clearing the remote control memory

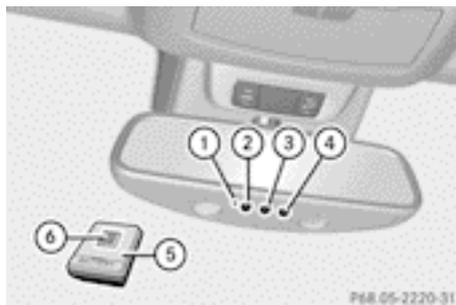

- ① Indicator lamp
- ②③④ Transmitter buttons
- ⑤ Garage door remote control
- ⑥ Transmitter button on the garage door remote control

- ▶ Turn the key to position 2 (▷ page 143) in the ignition lock.
- ▶ Press and hold transmitter buttons ② and ④ for approximately 20 seconds until indicator lamp ① flashes rapidly. The memory is cleared.

**i** Make sure that you clear the remote control memory before selling the vehicle.

### Frequencies for the garage door opener

#### Floor mat on the driver's side

#### **⚠ WARNING**

Make sure that there is sufficient clearance around the pedals when floor mats are used, and that the floor mats are properly secured.

The floor mats must be correctly secured at all times using the securing knob and retainers.

Before you drive off, check the floor mats and secure them if necessary. A floor mat which is not properly secured can slip and thereby interfere with the movement of the pedals.

Do not place floor mats on top of one another.

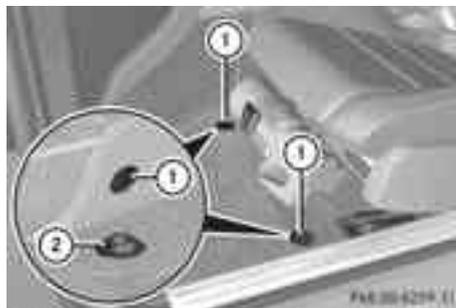

- ▶ Slide the seat backwards.
- ▶ **To fit:** lay the floor mat in the footwell.
- ▶ Press studs ① onto retainers ②.
- ▶ **To remove:** pull the floor mat out of retainers ②.
- ▶ Remove the floor mats.



Useful information .....	286
Engine compartment .....	286
Service .....	290
Care .....	291

## Useful information

- i** This Owner's Manual describes all models, series and optional equipment for your vehicle that were available at the time of going to press. Country-specific differences are possible. Note that your vehicle may not be fitted with all features described. This is also the case for systems and functions relevant to safety.
- i** Read the information on qualified specialist workshops: (▷ page 22).

## Engine compartment

### Bonnet

#### Important safety notes

#### WARNING

Do not pull the release lever while the vehicle is in motion. If you do so, the bonnet may open up and block your view.

#### WARNING

There is a risk of injury if the bonnet is open, even if the engine is not running.

Some engine components can become very hot.

To avoid the risk of burns, only touch those components described in the Owner's Manual and observe the relevant safety notes.

#### WARNING

The radiator fan between the radiator and the engine can start automatically, even if the key has been removed from the ignition lock. For this reason, you must not reach into the fan rotation area. You could otherwise be injured.

**Vehicles with a petrol engine:** The electronic ignition system uses high voltage. For this reason, you must never touch ignition system components (ignition coil, ignition cables, spark plug connectors or test socket) while:

- the engine is running
- the engine is being started
- the ignition is switched on and the engine is being cranked by hand

You could otherwise suffer an electric shock and be seriously or even fatally injured.

**Vehicles with a diesel engine:** The electronic injection control uses high voltage. For this reason, you must never touch injection system components while:

- the engine is running
- the engine is being started
- the ignition is switched on

You could otherwise suffer an electric shock and be seriously or even fatally injured.

#### WARNING

The windscreen wipers and wiper linkage could be set in motion.

When the bonnet is open, you or others could be injured by the wiper linkage.

Make sure that the windscreen wipers are switched off and that the key has been pulled out of the ignition lock before opening the bonnet.

- !** Make sure that the windscreen wipers are not folded away from the windscreen. Otherwise, you could damage the windscreen wipers or the bonnet.

## Opens the bonnet



The release lever on the bonnet is in the footwell on the left-hand side of the vehicle when viewed in the direction of travel.

- ▶ Make sure that the windscreen wipers are switched off.
- ▶ Pull release lever ① on the bonnet. The bonnet is released.



Vehicles with a petrol engine



Vehicles with a diesel engine

- ▶ Lift the bonnet slightly.
- ▶ **Petrol engine:** push the handle of bonnet catch ② in the direction of the arrow and lift the bonnet.
- ▶ **Diesel engine:** pull the handle of bonnet catch ② in the direction of the arrow and lift the bonnet.

## Closing the bonnet

### ⚠ WARNING

Make sure that nobody can become trapped as you close the bonnet.

- ▶ Lower the bonnet and let it fall from a height of approximately 20 cm.
- ▶ Check that the bonnet has engaged properly. If the bonnet can be raised slightly, it is not properly engaged. Open it again and close it with a little more force.

## Radiator

- ▶ **Vehicles with a diesel engine:** do not cover the radiator. Do not use thermal mats, insect protection covers or anything similar. Doing so can cause the Onboard Diagnostics System to display inaccurate values. Some of these values are legally required and must always be correct.

## Engine oil

### Notes on oil level

Depending on your driving style, the vehicle consumes up to 0.8 l of oil per 1,000 km. The oil consumption may be higher than this when the vehicle is new or if you frequently drive at high engine speeds.

## Checking the oil level using the oil dipstick

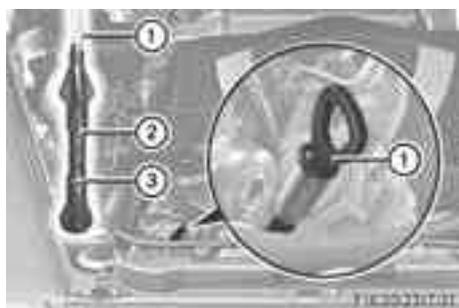

Example: oil dipstick

On the G 65 AMG, the oil level can be checked using the on-board computer only.

On all other models, the dipstick must be used to check the engine oil level.

When checking the oil level:

- park the vehicle on a level surface.
  - the engine should be switched off for approximately five minutes if the engine is at normal operating temperature.
  - the engine should be switched off for at least 30 minutes if the engine is not at operating temperature (i.e. if you only start the engine briefly).
- ▶ Pull oil dipstick ① out of the oil dipstick tube.
- ▶ Wipe off oil dipstick ①.
- ▶ Slowly slide oil dipstick ① into the guide tube to the stop, and take it out again. The oil level is correct if the level is between MIN mark ③ and MAX mark ②.
- ▶ Top up the oil if necessary.

## Checking the oil level using the on-board computer

**!** Do not add too much oil. Topping up with too much engine oil can result in damage to the engine or to the catalytic converter. Have excess engine oil siphoned off.

**G 65 AMG:** the oil level can be checked using the on-board computer only.

On all other models, the dipstick must be used to check the engine oil level.

When checking the oil level:

- park the vehicle on a level surface.
  - the engine should be switched off for approximately five minutes if the engine is at normal operating temperature.
- ▶ Make sure that the key is in position **2** in the ignition lock.
- ▶ Press the  or  button on the steering wheel to select the following message:

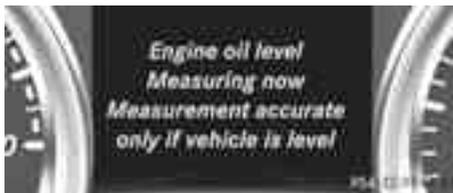

The measurement takes a few seconds. You will see one of the following messages in the multifunction display:

- Engine oil level OK
  - Add 1.0 l to reach maximum oil level
  - Add 1.5 litres to reach maximum oil level
  - Add 2.0 l to reach maximum oil level
- ▶ Top up the oil if necessary.

If the engine is at normal operating temperature and the **Engine oil Reduce oil level** message appears, the engine oil level is too high.

- ▶ Have excess oil siphoned off.

If the **Switch ignition on to check engine oil level** message appears:

- ▶ Turn the key to position **2** in the ignition lock (▷ page 143).

If the **Observe waiting time** message appears:

- ▶ **If the engine is at normal operating temperature:** repeat the measurement after about five minutes.
- ▶ **If the engine is not at normal operating temperature:** (e.g. if the engine was only started briefly) repeat the measurement after about 30 minutes.

If the **Engine oil level Not when engine on** message appears:

- ▶ Switch off the engine.
- ▶ **If the engine is at normal operating temperature:** wait about five minutes before carrying out the measurement.
- ▶ **If the engine is not at normal operating temperature:** e.g. if the engine was only started briefly, wait approximately 30 minutes before carrying out the measurement.

- ▶ **i** If you wish to cancel the measurement, press the  or  button on the multifunction steering wheel.

## Adding engine oil



### Environmental note

When topping up the oil, take care not to spill any. If oil enters the soil or waterways, it is harmful to the environment.

- ▶ **!** Do not add too much oil. If the oil level is above the "max" mark on the dipstick, too much oil has been added. This can lead to damage to the engine or the catalytic converter. Have excess oil siphoned off.



Engine oil cap (example: **G 65 AMG**)

- ▶ Turn cap  anti-clockwise and remove it.
- ▶ Top up with the amount of oil required.

Observe the specifications in the on-board computer when doing so or fill carefully to the maximum mark on the oil dipstick.

For further information on engine oil, see (▷ page 341).

- ▶ **i** The difference between the minimum mark and the maximum mark on the oil dipstick is approximately 2 litres.
- ▶ Replace cap  on the filler neck and tighten clockwise. Make sure that the cap locks securely into place.

## Other service products

### Checking the coolant level



### WARNING

The cooling system is pressurised. Therefore, only unscrew the cap once the engine has cooled down. The coolant temperature display must be less than 70 °C. Otherwise, you could be scalded if hot coolant escapes.

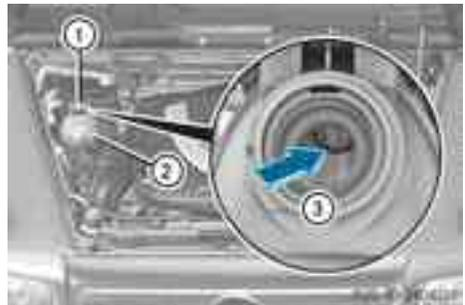

- ▶ Park the vehicle on a level surface. Only check the coolant level if the vehicle is on a level surface and the engine has cooled down.
- ▶ Turn the key to position **2** (▷ page 143) in the ignition lock.

- ▶ Check the coolant temperature display in the instrument cluster.  
The coolant temperature must be below 70 °C.
- ▶ Slowly turn cap ① half a turn anti-clockwise to allow excess pressure to escape.
- ▶ Turn cap ① further anti-clockwise and remove it.  
If the coolant is at the level of marker bar ③ in the filler neck when cold, there is enough coolant in coolant expansion tank ②.
- ▶ If the coolant level is approximately 1.5 cm above marker bar ③ in the filler neck when warm, there is enough coolant in coolant expansion tank ②.
- ▶ If necessary, top up with coolant that has been tested and approved by Mercedes-Benz.
- ▶ Replace cap ① and turn it clockwise as far as it will go.

For further information on coolant, see (▷ page 343).

### Topping up the windscreen washer system/headlamp cleaning system

#### WARNING

Windscreen washer fluid is highly flammable. Fire, naked flames and smoking are prohibited when handling washer fluid concentrate.

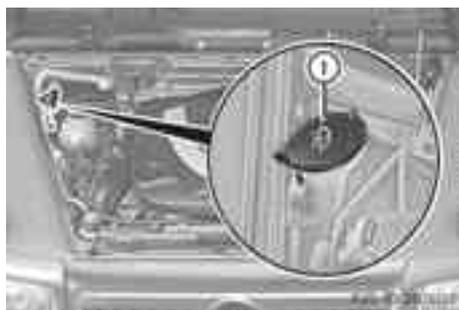

Example: washer fluid reservoir

- ▶ **To open:** pull cap ① upwards by the tab.
- ▶ Top up with the premixed washer fluid.
- ▶ **To close:** press cap ① onto the filler neck until it engages.

The washer fluid reservoir is used for both the windscreen washer system and the headlamp cleaning system.

Further information on windscreen washer fluid/antifreeze (▷ page 343).

## Service

### ASSYST service interval display

#### Service messages

Information on the type of service and service intervals (see separate Service Booklet).

You can obtain further information from a Mercedes-Benz Service Centre.

The ASSYST service interval display informs you of the next service due date.

If a service due date has been exceeded, you also hear a warning tone.

The multifunction display shows a service message for a few seconds, e.g.:

Service A in 99999 km

Service A due now

Service A 99999 km overdue

Maintaining the time-dependent service schedule:

- ▶ Note down the service due date displayed before disconnecting the battery.

Or:

- ▶ After reconnecting the battery, subtract the battery disconnection periods from the service date shown on the display.

The symbol and the letter indicate which type of service is due:

 Minor service **A**

 Major service **B**

The ASSYST service interval display does not take into account any periods of time during which the battery is disconnected.

### Hiding a service message

- ▶ To hide the service message, press the  back button on the multifunction steering wheel (▷ page 31)(▷ page 214).

### Displaying service messages

Use the buttons on the multifunction steering wheel.

- ▶ Switch the ignition on.
- ▶ Press  or  to select the **standard display** menu on the steering wheel (▷ page 215).
- ▶ Press  or  to select the ASSYST service interval display.  
The  or  service symbol and the service due date are displayed.

### Information about Service

Arduous operating conditions or increased loads on the vehicle will require some service work to be performed more often than for a vehicle in normal use. Such arduous conditions include regular city driving with frequent intermediate stops and use in mountainous terrain or on poor road surfaces.

For example, if the vehicle is used under arduous operating conditions, have air filters, engine oil and oil filters changed frequently and check the wheels often. Further information can be obtained at a qualified specialist workshop, e.g. a Mercedes-Benz Service Centre.

#### Fuel/water separator

##### Environmental note

Dispose of service products in an environmentally-responsible manner.

- ❗ If you continue driving without having the fuel/water separator serviced, this could cause damage to the engine. Any resulting damage is not covered by the warranty.

If the fuel/water separator needs servicing, the following message appears in the multifunction display:



You will also hear a brief warning tone.

- ▶ Visit a qualified specialist workshop as soon as possible.

### Care

#### General notes

Regular care of your vehicle is a condition for retaining the quality in the long term.

Use care products and cleaning agents recommended and approved by Mercedes-Benz.

- ❗ For cleaning your vehicle, do not use any of the following:

- dry, rough or hard cloths
- abrasive cleaning agents
- solvents
- cleaning agents containing solvents

Do not scrub.

Do not touch the surfaces or protective films with hard objects, e.g. a ring or ice scraper. You could otherwise scratch or damage the surfaces and protective film.

##### Environmental note

Dispose of empty packaging and cleaning cloths in an environmentally responsible manner.

- ❗ Do not park up the vehicle for an extended period straight after cleaning it, particularly

after having cleaned the wheels with wheel cleaner. Wheel cleaners could cause increased corrosion of the brake discs and brake pads/linings. For this reason, you should drive for a few minutes after cleaning. Braking heats the brake discs and the brake pads/linings, thus drying them. The vehicle can then be parked up.

## Care of the exterior

### Automatic car wash

#### WARNING

Braking efficiency is reduced after washing the vehicle. This could cause an accident. For this reason, following a car wash, drive with particular care until the brakes are dry.

**!** Preferably use car washes with adjustable high-pressure jets for pre-washing. This corresponds with the specifications for cabriolet programmes. In car washes that use high water pressures, there is a risk that a small amount of water may leak into the vehicle.

**!** **Cabriolet:** do not treat the vehicle with hot wax under any circumstances.

**!** Make sure that the automatic car wash is suitable for the size of the vehicle. Fold in the exterior mirrors before the vehicle is washed. The exterior mirrors could otherwise be damaged.

**!** Make sure that the automatic transmission is in position **N** when washing your vehicle in a tow-through car wash. The vehicle could be damaged if the transmission is in another position.

**!** Make sure that:

- the side windows and sliding sunroof are closed completely.
- the blower for the ventilation/heating is switched off (airflow control is turned to

position **0**/the **AUTO** and **A/C REST** buttons are switched off).

- the windscreen wiper switch is at position **0**.

The vehicle could otherwise be damaged.

You can wash the vehicle in an automatic car wash from the very start.

Wash off excess dirt before cleaning the vehicle in an automatic car wash.

After using an automatic car wash, wipe off wax from the windscreen and the wiper blades. This will prevent smears and reduce wiping noises caused by residue on the windscreen.

### High-pressure cleaning equipment

#### WARNING

Do not use high-pressure cleaners with circular-jet nozzles (dirt grinders) to clean your vehicle, in particular the tyres. You could otherwise damage the tyres and cause an accident.

**!** Always maintain a distance of at least 30 cm between the vehicle and the high-pressure cleaner nozzle. Information about the correct distance is available from the equipment manufacturer.

Move the high-pressure cleaner nozzle around when cleaning your vehicle.

Do not aim directly at any of the following:

- tyres
- door gaps, roof gaps, joints etc.
- soft top (Cabriolet)
- electrical components
- battery
- connectors
- lights
- seals
- trim elements
- ventilation slots

Damaged seals or electrical components can lead to leaks or failures.

## Cleaning the G-Class Cabriolet soft top

**!** Never use any of the following to clean the soft top:

- petrol
- thinner
- tar or stain remover
- other organic solvents

**!** Remove bird droppings immediately as they are corrosive and, therefore, can make the soft-top fabric leak. Do not use high-pressure cleaning equipment to clean the vehicle. Do not use sharp-edged equipment to remove ice and snow.

- ▶ **Light soiling:** you can clean the soft top while it is dry or rinse it with clear water.
- ▶ **Normal to heavy soiling:** clean the soft top with a brush and clear water. Clean stains and other heavy soiling with a brush and suitable soft-top cleaning agents. Always brush in the direction of the fabric, from front to back.

Frequent cleaning reduces the soft top's resistance to dirt.

To restore this resistance, clean your soft top with Mercedes-Benz Cabriolet care products. Incorrect cleaning and care, as well as ageing, can cause the soft-top seams to leak. Have the soft-top seams sealed at a qualified specialist workshop.

**i** Cover the soft top appropriately if you plan to leave the vehicle outside for a long period of time.

## Cleaning the wheels

**!** Do not use acidic wheel cleaning products to remove brake dust. This could damage wheel bolts and brake components.

**!** Do not park up the vehicle for an extended period straight after cleaning it, particularly after having cleaned the wheels with wheel cleaner. Wheel cleaners could cause increased corrosion of the brake discs and brake pads/linings. For this reason, you

should drive for a few minutes after cleaning. Braking heats the brake discs and the brake pads/linings, thus drying them. The vehicle can then be parked up.

## Cleaning the paintwork

**!** Do not affix:

- stickers
- films
- magnetic plates or similar items

to painted surfaces. You could otherwise damage the paintwork.

Scratches, corrosive deposits, areas affected by corrosion and damage caused by inadequate care cannot always be completely repaired. In such cases, visit a qualified specialist workshop.

- ▶ Remove impurities immediately, where possible, whilst avoiding rubbing too hard.
- ▶ Soak insect remains with insect remover and rinse off the treated areas afterwards.
- ▶ Soak bird droppings with water and rinse off the treated areas afterwards.
- ▶ Remove coolant, brake fluid, tree resin, oils, fuels and greases by rubbing gently with a cloth soaked in petroleum ether or lighter fluid.
- ▶ Use tar remover to remove tar stains.
- ▶ Use silicone remover to remove wax.

## Care and treatment of matt paintwork

**!** Never polish the vehicle or the light alloy wheels. Polishing makes the paintwork shiny.

**!** Never use paint cleaner, buffing or polishing products, or gloss preserver, e.g. wax. These products are only suitable for high-gloss surfaces. Their use on vehicles with matt finish leads to considerable surface damage (shiny, spotted areas).

Always have paintwork repairs carried out at a qualified specialist workshop.

**!** Do not use wash programs with a hot wax treatment under any circumstances.

If your vehicle has a clear matt finish, observe the following instructions in order to avoid damage to the paintwork due to incorrect care.

These notes also apply to light-alloy wheels with a clear matt finish.

- i** The vehicle should preferably be washed by hand using a soft sponge, car shampoo and plenty of water.
- i** Use only insect remover and car shampoo from the range of recommended and approved Mercedes-Benz care products.

### Cleaning the windows

#### WARNING

Switch off the windscreen wipers and remove the key from the ignition lock before cleaning the windscreen or the wiper blades. The windscreen wipers could otherwise move and injure you.

**!** Do not use dry cloths, abrasive products, solvents or cleaning agents containing solvents to clean the inside of the windows. Do not touch the insides of the windows with hard objects, e.g. an ice scraper or ring. There is otherwise a risk of damaging the windows.

**!** Clean the water drainage channels of the windscreen and the rear window at regular intervals. Deposits such as leaves, petals and pollen may under certain circumstances prevent water from draining away. This can lead to corrosion damage and damage to electronic components.

- ▶** Clean the inside and outside of the windows with a damp cloth and a cleaning agent that is recommended and approved by Mercedes-Benz.

### Cleaning the wiper blades

#### WARNING

Switch off the windscreen wipers and remove the key from the ignition lock before cleaning the windscreen or the wiper blades. The windscreen wipers could otherwise move and injure you.

- !** Do not pull on the wiper blade. Otherwise, the wiper blade could be damaged.
- !** Do not clean wiper blades too often and do not rub them too hard. Otherwise, the graphite coating could be damaged. This could cause wiper noise.
- !** Hold the wiper arm securely when folding back. The windscreen could be damaged if the wiper arm hits against it suddenly.
- ▶** Fold the wiper arms away from the windscreen.
- ▶** Carefully clean the wiper blades with a damp cloth.
- ▶** Fold the windscreen wipers back again before switching on the ignition.

### Cleaning the headlamps

- !** Only use cleaning agents or cleaning cloths which are suitable for plastic headlamp lenses. Unsuitable cleaning agents or cleaning cloths could scratch or damage the plastic headlamp lenses.
- ▶** Clean the headlamp lenses with a damp sponge and a mild cleaning agent, e.g. Mercedes-Benz car shampoo or cleaning cloths.

### Cleaning the sensors

- !** If you clean the sensors with a high-pressure cleaner, make sure that you keep a distance of at least 30 cm between the vehicle and the high-pressure cleaner nozzle. Information about the correct distance is available from the equipment manufacturer.

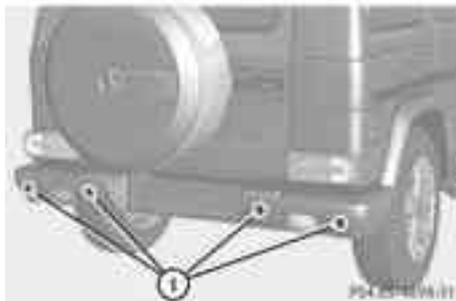

- ▶ Clean sensors ① of the driving systems with water, car shampoo and a soft cloth.

### Cleaning the reversing camera

- ❗ Do not clean the camera lens and the area around the reversing camera with a high-pressure cleaner.

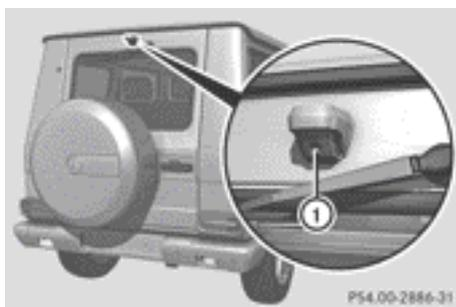

- ▶ Use clear water and a soft cloth to clean camera lens ①.

### Cleaning chrome parts

- ❗ Do not clean the exhaust pipe with acid-based cleaning agents such as sanitary cleansers or wheel cleaners.

Impurities combined with the effects of road grit and corrosive environmental factors may cause flash rust to form on the surface. You can restore the original shine to the chrome parts by cleaning them regularly, especially in winter and after washing.

- ▶ Clean the chrome parts with a chrome care product tested and approved by Mercedes-Benz.

### Cleaning the trailer coupling

#### ⓘ Environmental note

Dispose of oily and greasy cloths in an environmentally-responsible manner.

- ❗ Do not clean the ball coupling with a high-pressure cleaner. Do not use solvents.
- ❗ Please note the care instructions in the trailer coupling manufacturer's operating instructions.



Ball coupling ① must be cleaned if it becomes dirty or corroded.

- ▶ After cleaning, lightly oil or grease ball coupling ①.
- ▶ Check that the vehicle's trailer tow hitch is working properly.

- ⓘ You can also have the maintenance work on the ball coupling and the trailer tow hitch

carried out by a qualified specialist workshop.

### Interior care

#### Cleaning the display

**!** For cleaning, do not use any of the following:

- alcohol-based thinner or petrol
- abrasive cleaning agents
- commercially-available household cleaning agents

These may damage the display surface. Do not put pressure on the display surface when cleaning. This could lead to irreparable damage to the display.

- ▶ Before cleaning the display, make sure that it is switched off and has cooled down.
- ▶ Clean the display surface using a commercially available microfibre cloth and TFT/LCD display cleaner.
- ▶ Dry the display surface using a dry microfibre cloth.

#### Cleaning the plastic trim

##### WARNING

When cleaning the steering wheel boss and dashboard, do not use cockpit sprays or cleaning agents containing solvents. Cleaning agents containing solvents cause the surface to become porous, and as a result plastic parts may break away and be thrown around the interior when an airbag is deployed, which may result in severe injuries.

**!** Do not affix the following to plastic surfaces:

- stickers
- films
- scented oil bottles or similar items

You could otherwise damage the plastic.

**!** Do not allow cosmetics, insect repellent or sunscreen to come in contact with the plastic trim. This maintains the high-quality look of the surfaces.

- ▶ Wipe the plastic trim with a damp, lint-free cloth, e.g. a microfibre cloth.
- ▶ **Heavy soiling:** use car care and cleaning products recommended and approved by Mercedes-Benz. The surface may change colour temporarily. Wait until the surface is dry again.

#### Cleaning real wood and trim strips

**!** Do not use solvent-based cleaning agents such as tar remover, wheel cleaners, polishes or waxes. There is otherwise a risk of damaging the surface.

- ▶ Wipe the wooden trim and trim strips with a damp, lint-free cloth, e.g. a microfibre cloth.
- ▶ **Heavy soiling:** use car care and cleaning products recommended and approved by Mercedes-Benz.

#### Cleaning the seat covers

**!** Do not use microfibre cloths to clean genuine leather or artificial leather covers, as these are too aggressive and, if used often, may damage the cover.

**!** Observe the following when cleaning:

- clean genuine leather covers carefully with a damp cloth and then wipe the covers down with a dry cloth. Make sure that the leather does not become soaked. It may otherwise become rough and cracked. Only use leather care agents that have been tested and approved by Mercedes-Benz. You can obtain these from a qualified specialist workshop.
- clean artificial leather covers with a cloth moistened with a solution containing 1% detergent (e.g. washing-up liquid).
- clean cloth covers with a microfibre cloth moistened with a solution containing 1%

detergent (e.g. washing-up liquid). Rub carefully and always wipe entire seat sections to avoid leaving visible lines. Leave the seat to dry afterwards. Cleaning results depend on the type of dirt and how long it has been there.

- i** Note that regular care is essential to make sure that the appearance and comfort of the covers are retained over time.

### Cleaning the seat belts

---

- !** Do not clean the seat belts using chemical cleaning agents. Do not dry the seat belts at temperatures above 80 °C or in direct sunlight.
- ▶ Use clean, lukewarm water and soap solution.



Useful information .....	300
Where will I find...? .....	300
Flat tyre .....	305
Battery (vehicle) .....	305
Jump-starting .....	309
Towing and tow-starting .....	311
Electrical fuses .....	314

## Useful information

- i** This Owner's Manual describes all models, series and optional equipment for your vehicle that were available at the time of going to press. Country-specific differences are possible. Note that your vehicle may not be fitted with all features described. This is also the case for systems and functions relevant to safety.
- i** Read the information on qualified specialist workshops: (▷ page 22).

## Where will I find...?

## Warning triangle

## Removing the warning triangle

## G-Class long-wheelbase version

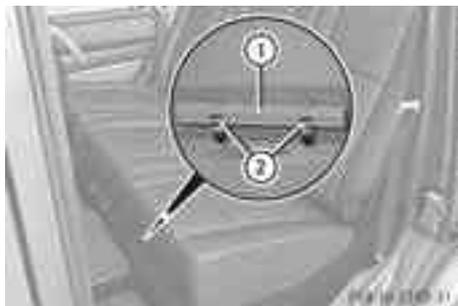

Warning triangle ① is attached to the underside of the rear bench seat.

- ▶ Release tabs ②.
- ▶ Remove warning triangle ①.

## G-Class Cabriolet



The first-aid kit is located in the tailgate behind a cover.

- ▶ Open the tailgate (▷ page 76).
- ▶ **To open the tailgate cover:** fold out handle ① in the direction of the arrow.
- ▶ Turn handle ① clockwise and fold up cover ② in the direction of the arrow.



- ▶ Remove warning triangle ③.

## Setting up the warning triangle



- ① Press-stud
  - ② Reflectors
  - ③ Feet
- ▶ Fold feet ③ down and out to the side.
  - ▶ Pull side reflectors ② up to form a triangle and lock them at the top using press-stud ①.

## First-aid kit



**G-Class long-wheelbase version:** first-aid kit ① is located in the stowage compartment in the right-hand door.



**G-Class Cabriolet:** the first-aid kit is located in the tailgate behind a cover.

- ▶ Open the tailgate (▷ page 76)
  - ▶ Open the tailgate cover (▷ page 300).
  - ▶ Remove first-aid kit ①.
- ❗ Check the expiry date on the first-aid kit at least once a year. Replace the contents if necessary, and replace any missing items.

## Fire extinguisher

- ❗ Keep the stowage compartment closed while the vehicle is in motion. It may otherwise be damaged.



Fire extinguisher (3) is located in the stowage compartment under the driver's seat.

- ▶ Pull handle (1) upwards.
- ▶ Pull the catch of cover (2) forwards in the direction of the arrow.
- ▶ Remove fire extinguisher (3) from the stowage compartment.

**i** Have fire extinguisher (3) refilled after each use and checked every one to two years. It may otherwise fail in an emergency.

Observe the legal requirements for each individual country.

## Vehicle tool kit

### General notes

The vehicle tool kit contains:

- vehicle tool kit with:
  - fuse extractor
  - Allen key, e.g. to operate the sliding roof manually in an emergency
  - pump lever for vehicle jack
  - screwdriver
  - wheel wrench
- jack

### Vehicle tool kit

#### G-Class long-wheelbase version

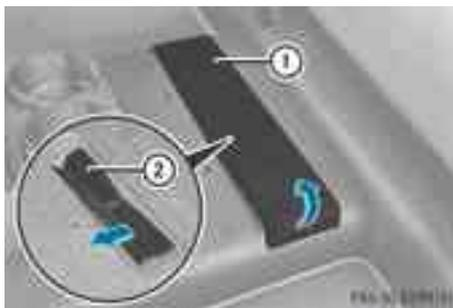

The vehicle tool kit is located under the cover in the footwell in front of the rear bench seat.

- ▶ Fold cover (1) to the side.
- ▶ Pull vehicle tool kit (2) out by the tab.

#### G-Class Cabriolet



Vehicle tool kit ① is located in the tailgate behind the cover

- ▶ Open the tailgate (▷ page 76).
- ▶ Open the tailgate cover (▷ page 300).
- ▶ Remove vehicle tool kit ①.

## Jack

### G-Class long-wheelbase version

**!** Make sure that, while fitting the vehicle jack, there are no cables on the holder, in order to avoid them becoming trapped.

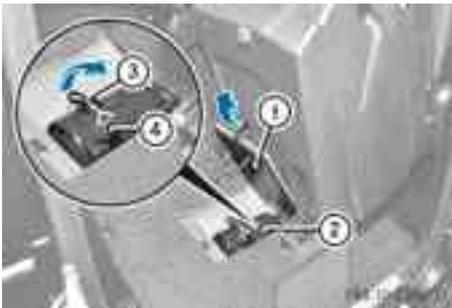

Jack ② is located under the rear bench seat on the right-hand side when viewed in the direction of travel.

- ▶ Fold rear bench seat (▷ page 270) forwards.
- ▶ Open cover ①.
- ▶ Pull bar ③ upwards and detach from tab ④.
- ▶ Remove jack ②.

### G-Class Cabriolet

**!** Make sure that, while fitting the vehicle jack, there are no cables on the holder, in order to avoid them becoming trapped.



The jack is located behind a cover in front of the front-passenger seat.

- ▶ Slide the seat back (▷ page 92).
- ▶ Pull pins ② out of sleeves ①.
- ▶ Pull sleeves ① out of cover ③.
- ▶ Remove cover ③.



- ▶ Pull bar ⑤ upwards and detach from tab ④.
- ▶ Remove jack ⑥.

### Exterior spare wheel bracket

#### General notes

You must not exceed the maximum speed of 50 mph (80 km/h) when using spare wheels of differing sizes.

- i** When changing a wheel, you should also observe the safety notes in the "Flat tyre" section (▷ page 325).

The spare wheel is on the outer side of the rear door.

## Removing the cover

### Protective tyre cover

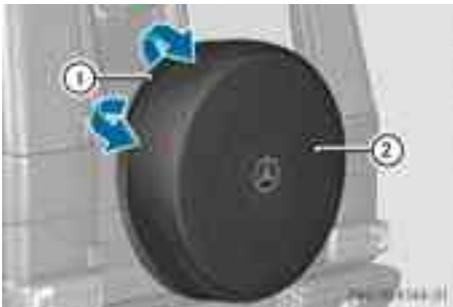

- ▶ Pull rubber ring ① of protective tyre cover ② apart.
- ▶ Pull off protective tyre cover ②.

### Stainless-steel spare wheel cover

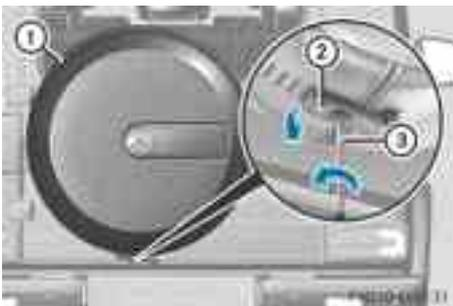

- ▶ Open the lock on cover ring ① with screwdriver ③ or a similar tool.
- ▶ Fold tab ② down.



- ▶ Pull cover ring ① apart and remove it.
- ▶ Pull off cover panel ④.

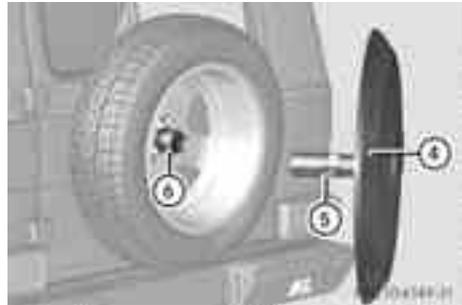

- ▶ When refitting cover panel ④, make sure that retainer ⑤ engages in recess ⑥.

## Removing the spare wheel

The spare wheel is heavy. Take particular note of this when removing the spare wheel.

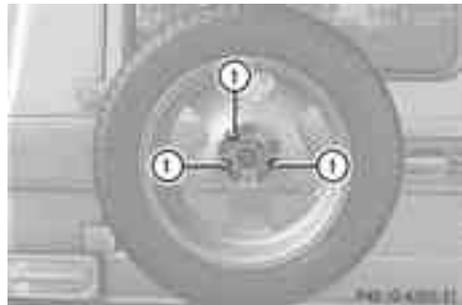

- ▶ Remove wheel nuts ①.
- ▶ Remove the spare wheel.

## Mounting the wheel

After changing a wheel:

- ▶ Secure the damaged wheel on the spare wheel bracket with wheel nuts ①. When doing so, make sure that the wheel cannot come loose.
- ▶ Cover the wheel with the tyre protection cover.

- ▶ **Vehicles with stainless-steel spare wheel cover:** make sure when refitting cover panel ④ that retainer ⑤ engages in recess ⑥ (▷ page 304).
- ▶ Make sure that tab ② is below when refitting cover ring ① (▷ page 304).
- ▶ For safety reasons, regularly check to ensure that the wheel is securely fastened.



### G-Class Cabriolet

- ▶ **i** Secure the spare wheel of the G-Class Cabriolet on spare wheel bracket ②, so that valve ① is accessible for checking the tyre pressure.

## Flat tyre

### Preparing the vehicle

- ▶ Stop the vehicle as far away as possible from traffic on solid, non-slippery and level ground.
- ▶ Switch on the hazard warning lamps (▷ page 109).
- ▶ Deactivate the automatic door locking (▷ page 223).
- ▶ Apply the parking brake.
- ▶ Bring the front wheels into the straight-ahead position.
- ▶ Move the selector lever to **P**.
- ▶ Switch off the engine.
- ▶ Remove the key from the ignition lock. The steering wheel lock stays active for as long as the key is removed.

- ▶ All occupants must get out of the vehicle. Make sure that they are not endangered as they do so.
- ▶ Make sure that no one is near the danger area while a wheel is being changed. Anyone who is not directly assisting in the wheel change should, for example, stand behind the barrier.
- ▶ Get out of the vehicle. Pay attention to traffic conditions when doing so.
- ▶ Close the driver's door.
- ▶ Place the warning triangle (▷ page 300) or warning lamps at a suitable distance. Observe legal requirements.

## Battery (vehicle)

### Important safety notes

Work on the battery, e.g. removing or installing, requires specialist knowledge and the use of special tools. Therefore, always have work on the battery carried out at a qualified specialist workshop.

### **WARNING**

Work carried out incorrectly on the battery can, for example, lead to a short circuit and damage your vehicle's electronic system. This can disrupt driving safety systems such as ABS (anti-lock braking system) or ESP® (Electronic Stability Program).

- If ABS malfunctions, the wheels can lock during braking. This limits the steerability of the vehicle when braking and the braking distance may increase. There is a risk of accident.
- If ESP® malfunctions, the vehicle will not be stabilised if it starts to skid or a wheel starts to spin. There is a risk of accident.

You should therefore have all work involving the battery carried out at a qualified specialist workshop.

**⚠ WARNING**

During the charging process, a battery produces hydrogen gas. If a short circuit occurs or sparks are created, the hydrogen gas can ignite. There is a risk of an explosion.

- Make sure that the positive terminal of a connected battery does not come into contact with vehicle parts.
- Never place metal objects or tools on a battery.
- It is important that you observe the described order of the battery terminals when connecting and disconnecting a battery.
- When jump-starting, make sure that the battery poles with identical polarity are connected.
- It is particularly important to observe the described order when connecting and disconnecting the jump leads.
- Never connect or disconnect the battery terminals while the engine is running.

**⚠ WARNING**

Electrostatic build-up can lead to the creation of sparks, which could ignite the highly explosive gases of a battery. There is a risk of an explosion.

Before handling the battery, touch the vehicle body to remove any existing electrostatic build-up.

**⚠ WARNING**

Battery acid is caustic. There is a risk of injury. Avoid contact with the skin, eyes or clothing. Do not inhale any battery gases. Do not lean over the battery. Keep children away from batteries. Wash battery acid immediately with water and seek medical attention.

- ❗ Have the battery checked regularly at a qualified specialist workshop. Observe the service intervals in the Service Booklet or contact a qualified specialist workshop for more information.

- ❗ Always have work on the battery carried out at a qualified specialist workshop. Should it, in exceptional circumstances, be absolutely necessary to disconnect the battery yourself, please observe the following:

- switch off the engine and remove the key. Check that all the indicator lamps in the instrument cluster are off. Otherwise, you may damage electronic components such as the alternator, for example.
- first, disconnect the negative terminal clamp, followed by the positive terminal clamp. Never swap the terminal clamps. The vehicle electronics may otherwise be damaged.
- on vehicles with automatic transmission, the transmission is locked in position **P** after disconnecting the battery. The vehicle is secured against rolling away. You can then no longer move the vehicle.

The battery and the cover of the positive terminal clamp must be fitted securely during operation.

- ❗ Have the battery checked and, if necessary, replaced at a qualified specialist workshop every two years or at least every 20,000 km.

**♻ Environmental note**

Batteries contain pollutants. It is illegal to dispose of them with the household rubbish. They must be collected separately and disposed of in an environmentally responsible recycling system.



Dispose of batteries in an environmentally responsible manner. Take discharged batteries to a qualified specialist workshop or to a collection point for used batteries.

In order for the battery to achieve the maximum possible service life, it must always be sufficiently charged.

Comply with safety precautions and take protective measures when handling batteries.



**WARNING**

Avoid the creation of sparks and heat.



Avoid fire, naked flames and smoking. Creation of sparks.



Battery acid is caustic.

Avoid contact with the skin, eyes or clothing.



Wear eye protection.



Keep children away.



Observe this Owner's Manual.

The vehicle battery, like other batteries, can discharge over time if you do not use the vehicle. In such cases, have the battery disconnected at a qualified specialist workshop. You can also charge the battery with a charger recommended by Mercedes-Benz. For more information, please contact a qualified specialist workshop.

Explosive gases are created during charging and jump-starting.

For safety reasons, Mercedes-Benz recommends that you only use batteries which have been tested and approved for your vehicle by Mercedes-Benz. These batteries provide increased impact protection to prevent vehicle occupants from suffering acid burns should the battery be damaged in the event of an accident.

Have the battery charge checked more frequently if you use the vehicle mainly for short

trips or if you leave it standing idle for a lengthy period. Consult a qualified specialist workshop if you wish to leave your vehicle parked up for a long period of time.

**i** When you park the vehicle, remove the key if you do not require any electrical consumers. The vehicle will then use very little energy, thus conserving battery power.

**i** If the power supply has been interrupted, e.g. due to a discharged battery, you will have to:

- set the clock. Information on setting the clock can be found in the separate operating instructions.

On vehicles with COMAND Online and a navigation system, the clock is set automatically.

- reset the head restraints on the front seats (> page 93).
- reset the function for folding the exterior mirrors in/out automatically, by folding the mirrors out once (> page 100).

### Charging the battery

#### **WARNING**

During charging and jump-starting, explosive gases can escape from the battery. There is a risk of an explosion.

Particularly avoid fire, naked flames, creating sparks and smoking. Ensure there is sufficient ventilation while charging and jump-starting. Do not lean over a battery.

#### **WARNING**

Battery acid is caustic. There is a risk of injury. Avoid contact with the skin, eyes or clothing. Do not inhale any battery gases. Do not lean over the battery. Keep children away from batteries. Wash battery acid immediately with water and seek medical attention.

 **WARNING**

A discharged battery can freeze at temperatures below freezing point. When jump-starting the vehicle or charging the battery, gases can escape from the battery. There is a risk of an explosion.

Allow the frozen battery to thaw out before charging it or jump-starting.

- !** Only charge the installed battery with a battery charger which has been tested and approved by Mercedes-Benz. These battery chargers allow the battery to be charged while still installed in the vehicle.
- !** Only use battery chargers with a maximum charging voltage of 14.8 V.
- !** Only charge the battery using the jump-start connection point.

Never charge a battery still installed in the vehicle unless a battery charger unit approved by Mercedes-Benz is being used.

A battery charger unit specially adapted for Mercedes-Benz vehicles and tested and approved by Mercedes-Benz is available as an accessory. It permits the charging of the battery in its installed position. Contact a Mercedes-Benz Service Centre for information and availability. Charge the battery in accordance with the separate instructions for the battery charger.

The jump-starting connection point is in the engine compartment (▷ page 309).

Read the battery charger's operating instructions before charging the battery.

- ▶ Open the bonnet (▷ page 287).
- ▶ Connect the battery charger to the positive terminal and earth point in the same order as when connecting the donor battery in the jump-starting procedure (▷ page 309).

## Jump-starting

### WARNING

Battery acid is caustic. There is a risk of injury.

Avoid contact with the skin, eyes or clothing. Do not inhale any battery gases. Do not lean over the battery. Keep children away from batteries. Wash battery acid immediately with water and seek medical attention.

### WARNING

Gases escaping from the battery during jump-starting may cause minor explosions. Avoid creating sparks. Keep naked flames away from the battery, and do not smoke.

Comply with the important safety precautions when handling batteries. You will find these under "Battery (vehicle) - important safety notes" in the index.

### WARNING

During charging and jump-starting, explosive gases can escape from the battery. There is a risk of an explosion.

Particularly avoid fire, naked flames, creating sparks and smoking. Ensure there is sufficient ventilation while charging and jump-starting. Do not lean over a battery.

### WARNING

During the charging process, a battery produces hydrogen gas. If a short circuit occurs or sparks are created, the hydrogen gas can ignite. There is a risk of an explosion.

- Make sure that the positive terminal of a connected battery does not come into contact with vehicle parts.
- Never place metal objects or tools on a battery.
- It is important that you observe the described order of the battery terminals when connecting and disconnecting a battery.
- When jump-starting, make sure that the battery poles with identical polarity are connected.
- It is particularly important to observe the described order when connecting and disconnecting the jump leads.
- Never connect or disconnect the battery terminals while the engine is running.

### WARNING

A discharged battery can freeze at temperatures below freezing point. When jump-starting the vehicle or charging the battery, gases can escape from the battery. There is a risk of an explosion. Allow the frozen battery to thaw out before charging it or jump-starting.

### WARNING

Non-combusted fuel can collect in the exhaust system and ignite. There is a risk of fire. Avoid repeated and lengthy starting attempts.

**!** Avoid repeated and lengthy starting attempts. Otherwise, non-combusted fuel may damage the catalytic converter and create a risk of fire.

Do not use a rapid charging device to start the vehicle.

Make sure the jump leads are not damaged.

Make sure the jump leads are not touching any other metal objects when they are connected to the battery.

If the indicator/warning lamps do not light up at temperatures around or below freezing point, the discharged battery is likely to be frozen (a commonplace scenario). In this case, do not jump-start the vehicle or recharge the battery.

Once the battery has thawed out, its service life may be dramatically reduced.

The starting characteristics can be impaired, particularly at low temperatures.

It is recommended that you have the thawed out battery checked at a qualified specialist workshop.

Do not use a rapid charging device to start the vehicle. If your vehicle's battery is discharged, the engine can be jump-started from another vehicle or from a second battery using jump leads. Observe the following points:

- The battery is not accessible in all vehicles. If the other vehicle's battery is not accessible, jump-start the vehicle using a second battery or a jump-starting device.
- **Vehicles with a petrol engine:** only jump-start the vehicle when the engine and exhaust system are cold.
- Do not start the engine if the battery is frozen. Let the battery thaw first.
- Jump-starting may only be performed from batteries with a nominal voltage of 12 V.
- Only use jump leads that have a sufficient cross-section and insulated terminal clamps.
- If the battery is fully discharged, leave the battery that is being used to jump-start connected for a few minutes before attempting to start. This charges the empty battery a little.
- Make sure that the two vehicles do not touch.

Make sure that:

- The jump leads are not damaged.
  - Non-insulated parts of the terminal clamps do not come into contact with other metal parts while the jump leads are connected to the battery.
  - The jump leads cannot come into contact with parts such as the pulley or the fan. These parts move when the engine is started and while it is running.
- ▶ Apply the parking brake.
  - ▶ Move the selector lever to **P**.
  - ▶ Switch off all electrical consumers (e.g. radio, blower, etc.).
  - ▶ Open the bonnet (▷ page 287).

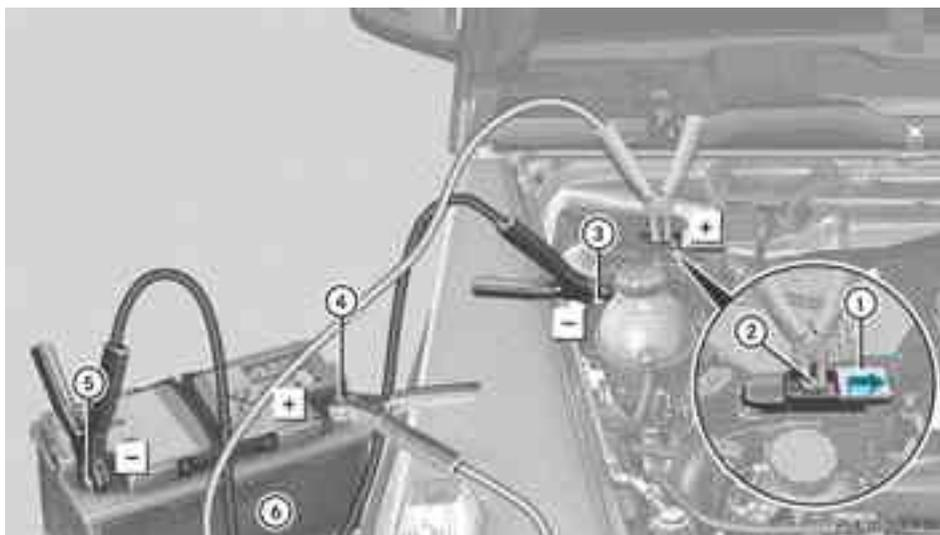

Position number ⑥ identifies the charged battery of the other vehicle or an equivalent jump-starting device.

The jump-start terminal point consists of terminals ② and ④.

- ▶ Lift up cover ① of positive terminal ② in the direction of the arrow.
- ▶ Connect positive terminal ② on your vehicle to positive terminal ④ of donor battery ⑥ using the jump lead. Begin with your own battery.
- ▶ Start the engine of the donor vehicle and run it at idling speed.
- ▶ Connect negative terminal ⑤ of donor battery ⑥ to earth point ③ of your vehicle using the jump lead, connecting the jump lead to donor battery ⑥ first.
- ▶ Start the engine.
- ▶ First, remove the jump lead from earth point ③ and negative terminal ⑤, then from positive terminal ② and positive terminal ④, each time disconnecting from the battery on your own vehicle first.
- ▶ Have the battery checked at a qualified specialist workshop.

**i** Jump-starting is not considered to be a normal operating condition.

**i** Jump-starting cables and further information regarding jump-starting can be obtained at any qualified specialist workshop.

## Towing and tow-starting

### Important safety notes

#### **⚠ WARNING**

The vehicle is braked when the HOLD function or DISTRONIC PLUS is activated. Therefore,

deactivate HOLD and DISTRONIC PLUS if the vehicle is to be towed.

**!** You may tow the vehicle for a maximum of 50km. A towing speed of 50 km/h must not be exceeded.

For towing distances over 50 km, the entire vehicle must be lifted up and transported.

- ❗ Only secure the tow cable or towing bar to the towing eyes. You could otherwise damage the vehicle.
- ❗ Do not use the towing eyes for recovery purposes as this could damage the vehicle. If in doubt, recover the vehicle with a crane.
- ❗ When towing, pull away slowly and smoothly. If the tractive power is too high, the vehicles could be damaged.
- ❗ Your vehicle is equipped with an automatic transmission. Therefore, you must not have the vehicle tow-started. The transmission may otherwise be damaged.

#### ⚠ WARNING

If the weight of the vehicle to be towed or tow-started is greater than the permissible gross weight of your vehicle:

- the towing eye could detach itself
- the vehicle/trailer combination could overturn.

There is a risk of an accident.

When towing or tow-starting another vehicle, its weight should not be greater than the permissible gross weight of your vehicle.

Information on your vehicle's gross vehicle weight rating can be found on the vehicle identification plate (> page 336).

Observe the legal requirements for the relevant countries when towing.

It is better to have the vehicle transported than to have it towed.

If the transfer case can be shifted into neutral **N**, you can tow the vehicle.

If the transfer case cannot be shifted into neutral **N**, you can tow the vehicle with one axle raised. Please bear the following in mind:

- remove the propeller shaft between the transfer case and the rolling axle.
- turn the key to position **1** in the ignition lock (> page 143).

The battery must be connected and charged. Otherwise, you:

- cannot turn the key in the ignition lock to position **2** (> page 143)
  - cannot shift the automatic transmission to position **N**
- ❗ Deactivate the automatic locking feature (> page 74). You could otherwise be locked out when pushing or towing the vehicle. Deactivate tow-away protection before the vehicle is towed (> page 65).

### Towing eyes

#### Towing eyes, front



① Towing eyes, front

#### Towing eye, rear



Rear towing eye ① is located under the bumper, on the left-hand side when viewed in the direction of travel.

### Towing the vehicle with both axles on the ground

It is important that you observe the safety instructions when towing away your vehicle (▷ page 311).

- ▶ Switch on the hazard warning lamps (▷ page 109).
- i** In order to signal a change of direction when towing the vehicle with the hazard warning lamps switched on, use the combination switch as usual. In this case, only the turn signals for the desired direction flash. When you reset the combination switch, the hazard warning lamps start flashing again.
- ▶ Turn the key to position **2** in the ignition lock (▷ page 143).
- ▶ When the vehicle is stationary, depress the brake pedal and keep it depressed.
- ▶ Shift the transfer case to **neutral** (▷ page 203).
- ▶ Shift the automatic transmission to position **N**.
- ▶ Release the brake pedal.
- ▶ Release the parking brake (▷ page 164).
- i** The transmission can only change gear when the battery has sufficient charge. If you cannot move the selector lever to **N**, you must remove the propeller shafts to the driven axles.

### Transporting the vehicle

- !** Only lash the vehicle down by the wheels or wheel rims, not by parts of the vehicle such as axle or steering components. Otherwise, the vehicle could be damaged.

Use the towing eyes to pull the vehicle if it needs to be transported on a trailer or transporter (▷ page 312).

- ▶ Apply the parking brake.
- ▶ Turn the key to position **2** in the ignition lock (▷ page 143).

- ▶ Move the selector lever to **N**.
- ▶ Shift the transfer case to **neutral** (▷ page 203).
- ▶ Secure the towing cable to the towing eyes (▷ page 312).
- ▶ Make sure that the vehicle cannot roll away.
- ▶ Release the parking brake.
- ▶ Load the vehicle onto the transporter.

### As soon as the vehicle is loaded:

- ▶ Apply the parking brake.
- ▶ Shift the automatic transmission to position **P**.
- ▶ Turn the key to position **0** in the ignition lock (▷ page 143) and remove it.
- ▶ Secure the vehicle.

### Recovering a vehicle that has become stuck

- !** When recovering a trapped vehicle, do not jerk the vehicle or pull it at an angle. If the tractive power is too high, the vehicles could be damaged.

If the drive wheels get trapped on loose or muddy ground, recover the vehicle with the utmost care, especially so if the vehicle is laden.

Never attempt to recover a vehicle with a trailer attached.

Pull out the vehicle backwards, if possible, using the tracks it made when it became stuck.

### Towing in the event of malfunctions

#### General notes

- !** If you are removing the propeller shaft, use M10 nuts as spacers on the M8 bolts and secure them with M8 nuts. New self-locking nuts must be used when the propeller shafts are refitted.

- ▶ Observe the safety notes as you do so (▷ page 311).

**i** Consult a Mercedes-Benz Service Centre.

### Engine damage, gear damage or electrical faults

- ▶ Move the selector lever to position **N** (▷ page 149).
- ▶ Shift the transfer case to **neutral** (▷ page 203).

### In the event of damage to the transfer case

Have the propeller shafts between the axles and the transfer case removed.

### In the event of damage to the front axle

Have the propeller shaft between the rear axle and the transfer case removed.

Have the vehicle towed with the front axle raised.

### In the event of damage to the rear axle

Have the propeller shaft between the front axle and the transfer case removed.

Then, have the vehicle towed with the rear axle raised and with wheel rollers under the front axle.

## Electrical fuses

### Important safety notes

#### **WARNING**

Only use fuses that have been approved for Mercedes-Benz vehicles and which have the correct fuse rating for the systems concerned. Do not attempt to repair or bridge faulty fuses. Using fuses which have not been approved or attempting to repair or bridge faulty fuses could cause the fuse to be overloaded and result in a fire. Have the cause

traced and rectified at a qualified specialist workshop.

- !** Only use fuses that have been approved for Mercedes-Benz vehicles and which have the correct fuse rating for the system concerned. Otherwise, components or systems could be damaged.

The fuses in your vehicle serve to disconnect faulty circuits. If a fuse blows, all the components on the circuit and their functions will fail.

Blown fuses must be replaced with fuses of the same rating, which you can recognise by the colour and fuse rating. The fuse ratings are listed in the fuse allocation chart.

If the newly inserted fuse also blows, have the cause traced and rectified at a qualified specialist workshop, e.g. a Mercedes-Benz Service Centre.

### Before replacing a fuse

- ▶ Park the vehicle and apply the parking brake.
- ▶ Switch off all electrical consumers.
- ▶ Remove the key from the ignition lock. All indicator lamps in the instrument cluster must be off.

The fuses are located in various fuse boxes:

- Main fuse box on the driver's side of the dashboard
- Fuse box in the front-passenger footwell
- Fuse box in the transmission tunnel
- Fuse box in the battery case

The fuse allocation chart and the spare fuses are in the main fuse box on the dashboard (▷ page 315).

You will find the fuse removal device in the vehicle tool kit (▷ page 302).

### Dashboard fuse box

- ❗ Do not use a pointed object such as a screwdriver to open the cover in the dashboard. You could damage the dashboard or the cover.
- ❗ Make sure that no moisture can enter the fuse box when the cover is open.
- ❗ When closing the cover, make sure that it is lying correctly on the fuse box. Moisture seeping in or dirt could otherwise impair the operation of the fuses.



- ▶ Open the driver's door.
- ▶ **To open:** pull cover ① outwards in the direction of the arrow and remove it.
- ▶ **To close:** clip in cover ① on the front of the dashboard.
- ▶ Fold cover ① inwards until it engages.

### Fuse box in the front-passenger foot-well

- ❗ Make sure that no moisture can enter the fuse box when the cover is open.
- ❗ When closing the cover, make sure that it is lying correctly on the fuse box. Moisture seeping in or dirt could otherwise impair the operation of the fuses.

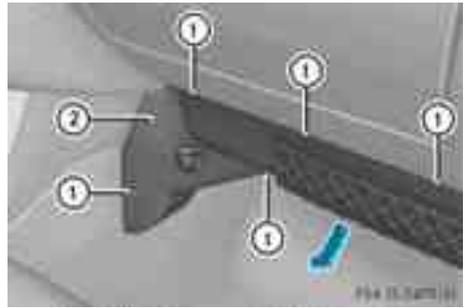

- ▶ Unscrew screws ①.
- ▶ Lift up cover ② in the direction of the arrow.



③ Fuse box

### Fuse box in the transmission tunnel

- ❗ Make sure that no moisture can enter the fuse box when the cover is open.
- ❗ When closing the cover, make sure that it is lying correctly on the fuse box. Moisture seeping in or dirt could otherwise impair the operation of the fuses.



- ▶ Fold down the cup holder on the centre console (▷ page 275).
- ▶ Adjust the front-passenger seat to its foremost position (▷ page 92).
- ▶ To open: remove screws ①.
- ▶ Remove cover ② in the direction of the arrow.
- ▶ **To close:** clip in cover ②.
- ▶ Fit cover ② with screws ①.

### Fuse box in the battery case

The fuses in the battery case do not usually need to be replaced. If a fuse change is necessary, consult a qualified specialist workshop.

Useful information .....	318
Important safety notes .....	318
Operation .....	318
Winter operation .....	319
Tyre pressure .....	321
Changing a wheel .....	325
Wheel and tyre combinations .....	329

## Useful information

- i** This Owner's Manual describes all models, series and optional equipment for your vehicle that were available at the time of going to press. Country-specific differences are possible. Note that your vehicle may not be fitted with all features described. This is also the case for systems and functions relevant to safety.
- i** Read the information on qualified specialist workshops: (▷ page 22).

## Important safety notes

### Warning

A flat tyre severely impairs the driving, steering and braking characteristics of the vehicle. There is a risk of an accident.

Do not drive with a flat tyre. Immediately replace the flat tyre with your spare wheel, or consult a qualified specialist workshop.

### WARNING

Tyres, wheels or accessories which have not been approved by Mercedes-Benz for your vehicle, or are not used as they should be, can impair driving safety. As a result, you could cause an accident. Before purchasing and using them, enquire about their suitability, legal stipulations and factory recommendations at a Mercedes-Benz Service Centre.

Accessories that are not approved for your vehicle by Mercedes-Benz or are not being used correctly can impair the operating safety.

Before purchasing and using non-approved accessories, visit a qualified specialist workshop and enquire about:

- suitability
- legal stipulations
- factory recommendations

Information on the dimensions and types of wheels and tyres for your vehicle can be found in the "Wheel/tyre combinations" section (▷ page 329).

Information on air pressure for the tyres on your vehicle can be found:

- on the tyre pressure label on the fuel filler flap
- in the "Tyre pressure" section

Modification work on the brake system and wheels is not permitted, nor is the use of spacer plates or brake dust shields. This invalidates the general operating permit for the vehicle.

- i** Further information on wheels and tyres can be obtained at any qualified specialist workshop.

## Operation

### Notes on driving

Check the tyre pressures when the vehicle is heavily laden and, if necessary, adjust.

While driving, pay attention to vibrations, noises and unusual handling characteristics, e.g. pulling to one side. This may indicate that the wheels or tyres are damaged. If you suspect that a tyre is defective, reduce your speed immediately. Stop the vehicle as soon as possible to check the wheels and tyres for damage. Hidden tyre damage could also be causing the unusual handling characteristics. If you find no signs of damage, have the tyres and wheels checked at a specialist workshop.

When parking your vehicle, make sure that the tyres do not get deformed by the kerb or other obstacles. If it is necessary to drive over kerbs, speed humps or similar elevations, try to do so slowly and at an obtuse angle. Otherwise, the tyres, particularly the sidewalls, may be damaged.

### Regular checking of wheels and tyres

- Regularly check the wheels and tyres of your vehicle for damage at least every 14 days, as well as after driving off-road or on rough roads. Damage includes cuts, punctures, cracks and bulges on tyres or severe corrosion or deformation on wheels, for example. Damaged wheels can cause a loss of tyre pressure.
- Regularly check the tyre tread depth and the condition of the tread across the whole width of the tyre (▷ page 319). In order to inspect the inner side of the tyre surface, turn the steering wheel to full lock.
- All wheels must have a valve cap to protect the valve against dirt and moisture. Do not fit anything onto the valve other than the standard valve cap or a valve cap approved by Mercedes-Benz for your vehicle.  
Do not fit anything onto the valve, such as tyre pressure monitoring systems.
- You should regularly check the pressure of all your tyres including the spare wheel, particularly prior to long trips. Adjust the tyre pressure as necessary (▷ page 324).

The service life of tyres depends on various factors, including the following:

- driving style
- tyre pressure
- tyre mileage

### Tyre tread

#### WARNING

Please keep in mind that:

- tyre grip decreases rapidly on wet roads when the tread depth is less than 3 mm. Thus, you should replace tyres that have insufficient tread.
- winter tyres should be replaced when the tread depth is 4 mm or less, as they no longer provide adequate grip.
- the tread on a tyre may not wear evenly. Thus, you should regularly check the tread

depth and the condition of the tread across the entire width of all tyres. If necessary, turn the front wheels to full lock in order to inspect the tyre tread more easily.

Otherwise, you could lose control of the vehicle and cause an accident due to the reduced grip of the tyres on the road.

### Selecting, fitting and replacing tyres

- Only fit tyres and wheels of the same type and make.
- Only fit approved tyres of the correct size onto the wheels.
- Tyres are supplied with a protective layer from the factory. Run in new tyres at moderate speeds for the first 100 km. They only reach their full performance after this distance.
- Do not drive with tyres which have too little tread depth. This otherwise significantly reduces the traction on wet roads (aquaplaning).
- Replace the tyres after six years at the latest, regardless of wear. This also applies to the spare wheel.

### Winter operation

#### General notes

Have your vehicle winterproofed at a qualified specialist workshop at the onset of winter. Observe the notes in the "Changing a wheel" section (▷ page 325).

#### Driving with summer tyres

At temperatures below +7 °C, summer tyres lose elasticity and therefore traction and braking power. Change the tyres on your vehicle to M+S tyres. Using summer tyres at very cold temperatures could cause tears to form, thereby damaging the tyres permanently.

Mercedes-Benz cannot accept responsibility for this type of damage.

### M+S tyres

#### WARNING

M+S tyres with a tyre tread depth of less than 4 mm are not suitable for use in winter as they do not provide sufficient traction. There is a risk of accident.

M+S tyres with a tread depth of less than 4 mm must be replaced.

#### WARNING

The spare wheel and M+S tyres have different tyre characteristics. Driving characteristics can be severely impaired when you fit the spare wheel. There is a risk of an accident.

You should therefore adapt your driving style and drive carefully. Have the spare wheel replaced with a new wheel with an M+S tyre at the nearest qualified specialist workshop.

At temperatures below +7 °C, use winter tyres or all-season tyres. Both types of tyre are identified by the M+S marking.

Only winter tyres bearing the  snowflake symbol in addition to the M+S marking provide the best possible grip in wintry road conditions. Only these tyres will allow driving safety systems such as ABS and ESP® to function optimally in winter, as these tyres have been designed specifically for driving on snow.

Use M+S tyres of the same make and tread on all wheels to maintain safe handling characteristics.

Always observe the maximum permissible speed specified for the M+S tyres you have fitted.

If you fit M+S tyres that have a lower maximum permissible speed than that of the vehicle, affix an appropriate warning sign in the driver's field of vision. This can be obtained at a qualified specialist workshop.

Under these circumstances, you should also restrict the maximum speed of the vehicle using variable SPEEDTRONIC so that it does not exceed the maximum permissible speed for the M+S tyres (> page 178).

When you have fitted the M+S tyres:

- ▶ Check the tyre pressures (> page 323).
- ▶ Restart the tyre pressure monitor (> page 324).

**i** You can obtain information about winter tyres that have been approved by Mercedes-Benz especially for your vehicle at any Mercedes-Benz Service Centre.

**i** For further information about tyres, see (> page 329).

### Snow chains

**i** Information about the use of snow chain compatible AMG winter tyres is applicable for AMG tyres. Use of snow chains is only permissible with these tyres.

For safety reasons, Mercedes-Benz recommends that you only use snow chains that have been specially approved for your vehicle by Mercedes-Benz, or that are of a corresponding standard of quality.

- only use snow chains when the road surface is completely snow-covered. Remove the snow chains as soon as possible when you come to road that is not snow-covered.
- local regulations may restrict the use of snow chains. Observe the appropriate regulations if you wish to fit snow chains.
- Do not exceed the maximum permissible speed of 50 km/h.

If you intend to fit snow chains, please bear the following points in mind:

- snow chains cannot be fitted to all wheel/tyre combinations (> page 62).
- fit the snow chains on all four wheels for maximum tractive power and driving stability. Observe the manufacturer's fitting instructions.

- i** You may wish to deactivate ESP® (▷ page 62) when pulling away with snow chains fitted. This way you can allow the wheels to spin in a controlled manner, achieving an increased driving force (cutting action).

## Tyre pressure

### Tyre pressure specifications

#### Important safety notes

##### WARNING

Underinflated or overinflated tyres pose the following risks:

- the tyres may burst, especially as the load and vehicle speed increase.
- the tyres may wear excessively and/or unevenly, which may greatly impair tyre traction.
- the driving characteristics, as well as steering and braking, may be greatly impaired.

There is a risk of an accident.

Observe the recommended tyre pressure and check the tyre pressure of all the tyres including the spare wheel:

- at least every two weeks
- when the load changes
- before embarking on a longer journey
- for changed operating conditions, e.g. off-road driving

If necessary, correct the tyre pressure.

##### WARNING

If you fit unsuitable accessories onto tyre valves, the tyre valves may be overloaded and malfunction, which can cause tyre pressure loss. Due to their design, retrofitted tyre pressure monitors keep the tyre valve open. This can also result in tyre pressure loss. There is a risk of accident.

Only screw standard valve caps or valve caps specifically provided by Mercedes-Benz for your vehicle onto the tyre valve.

##### WARNING

If the tyre pressure drops repeatedly, the wheel, valve or tyre may be damaged. Tyre pressure that is too low may result in a tyre blow-out. There is a risk of accident.

- Check the tyre for foreign objects.
- Check whether the wheel is losing air or the valve is leaking.

If you are unable to rectify the damage, contact a qualified specialist workshop.

##### Environmental note

Check the tyre pressure regularly, at least every 14 days.

#### General notes

You will find a table of tyre pressures for various operating conditions on the inside of your vehicle's fuel filler flap.

**Operation with a trailer:** the applicable value for the rear tyres is the maximum tyre pressure value stated in the table inside the fuel filler flap.

The table inside the fuel filler flap may state tyre pressures for different load conditions. These are defined in the table as different numbers of passengers and amounts of luggage. The actual number of seats may vary – for more information, please refer to the vehicle's registration documents.

If tyre sizes are not specified, the tyre pressures stated on the tyre pressure information label apply for all tyres approved for this vehicle.

## Tyre pressure table



If a tyre size precedes a tyre pressure, the tyre pressure information following is only valid for that tyre size.

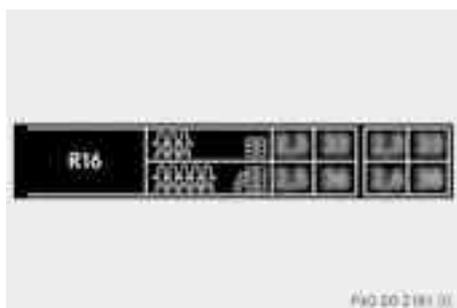
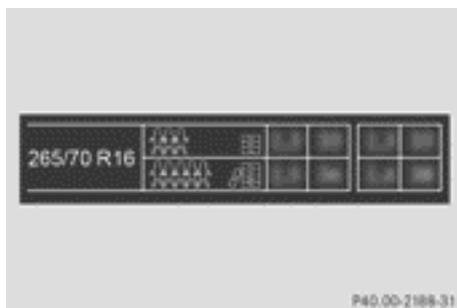

Instead of the complete tyre size, the rim diameter alone, for example **R16**, may be listed.



Rim diameter ① is part of the tyre size and can be found on the tyre sidewall.

Use a suitable pressure gauge to check the tyre pressure. The outer appearance of a tyre does not permit any reliable conclusion about the tyre pressure.

On vehicles fitted with the electronic tyre pressure monitor, the tyre pressure can be checked using the on-board computer.

If possible, only correct tyre pressures when the tyres are cold.

The tyres are cold:

- if the vehicle has been parked with the tyres out of direct sunlight for at least three hours and
- if the vehicle has not been driven further than 1.6 km

Depending on the ambient temperature, the speed you are driving at and the load on the tyres, the tyre temperature and thus the tyre pressure change by approximately 10 kPa (0.1 bar/1.5 psi) per 10 °C. Take this into account when checking the pressure of warm tyres. Only correct the tyre pressure if it is too low for the current operating conditions.

Driving with tyre pressure that is too high or too low can:

- shorten the service life of the tyres
- cause increased tyre damage
- have a negative effect on handling characteristics and thus the driving safety (e.g. aquaplaning)

- i** The tyre pressure values given for low loads are minimum values which offer you good ride comfort characteristics. However, you can also use the values given for higher loads. These are permissible and will not adversely affect the running of the vehicle.

## Checking the tyre pressures

### Important safety notes

Observe the notes on tyre pressure: (▷ page 321).

Information on air pressure for the tyres on your vehicle can be found:

- on the vehicle's tyre and loading information table on the B-pillar (▷ page 322)
- on the tyre pressure label on the fuel filler flap (▷ page 322)
- in the "Tyre pressure information" section
- in the "Tyre pressure information" section (▷ page 321)

### Checking the tyre pressure manually

To determine and set the correct tyre pressure, proceed as follows:

- ▶ Remove the valve cap of the tyre that is to be checked.
- ▶ Press the tyre pressure gauge securely onto the valve.
- ▶ Read the tyre pressure and compare it with the recommended value on the tyre and loading information table on the B-pillar on the driver's side of your vehicle (▷ page 322).
- ▶ **The tyre pressure is too low:** increase the tyre pressure to the recommended value.
- ▶ **The tyre pressure is too high:** press down the metal pin in the valve using the tip of a pen, for example. Air is released from the tyre.
- ▶ Check the tyre pressure again with the tyre pressure gauge.

- ▶ Screw the valve cap onto the valve.
- ▶ Repeat these steps for the other tyres.

## Tyre pressure monitor

### Important safety notes

It is the driver's responsibility to set the tyre pressure to the recommended cold tyre pressure suitable for the operating situation (▷ page 321). Note that the correct tyre pressure for the current operating situation must first be taught-in to the tyre pressure monitor. If there is a substantial loss of pressure, the warning threshold for the warning message is aligned to the reference values taught-in. Restart the tyre pressure monitor after adjusting to the cold tyre pressure (▷ page 324). The current pressures are saved as new reference values. This will ensure that a warning message will only appear if the tyre pressure drops significantly. The tyre pressure monitor does not warn you of an incorrectly set tyre pressure. Observe the notes on the recommended tyre pressure (▷ page 321).

The tyre pressure monitor is not able to warn you of a sudden loss of pressure, e.g. if the tyre is penetrated by a foreign object. In the event of a sudden loss of pressure, bring the vehicle to a halt by braking carefully. Avoid abrupt steering manoeuvres.

If a tyre pressure monitor system is fitted, the vehicle's wheels have sensors fitted that monitor the tyre pressures in all four tyres. The tyre pressure monitor warns you when the pressure drops in one or more of the tyres. The tyre pressure monitor only functions if the correct sensors are fitted to all wheels.

Information on tyre pressures is displayed in the multifunction display. After a few minutes of driving, the current tyre pressure of each tyre is shown in the multifunction display.

The tyre pressure values indicated by the on-board computer may differ from those meas-

ured at a filling station with a pressure gauge. The tyre pressures shown by the on-board computer refer to those measured at sea level. At high altitudes, the tyre pressure values indicated by a pressure gauge are higher than those shown by the on-board computer. In this case, do not reduce the tyre pressures. The operation of the tyre pressure monitor can be affected by interference from radio transmitting equipment (e.g. radio head-phones, two-way radios) that may be being operated in or near the vehicle.

### Checking tyre pressure electronically

- ▶ Make sure that the key is in position 2 (▷ page 143) in the ignition lock.
- ▶ Press the ◀ or ▶ button on the steering wheel to select the **Serv.** menu.
- ▶ Press the ▲ or ▼ button to select **Tyre pressure**.
- ▶ Press the **OK** button.  
The current tyre pressure for each wheel will be displayed in the multifunction display.

If the vehicle has been parked for over 20 minutes, the message **Tyre pressures will be displayed after a few minutes of driving** appears.

After a teach-in period, the tyre pressure monitor automatically recognises new wheels or new sensors. As long as a clear allocation of the tyre pressure values to the individual wheels is not possible, the **Tyre pressure monitor active** display message is shown instead of the tyre pressure display. The tyre pressures are already being monitored.

- ❗ If a spare wheel is fitted, the system may continue to show the tyre pressure of the wheel that has been removed for a few minutes. If this occurs, note that the value displayed for the position where the spare tyre is fitted is not the same as the spare tyre's current tyre pressure.

### Warning messages of the tyre pressure monitor

If the tyre pressure monitor detects a significant pressure loss on one or more tyres, a warning message is shown in the multifunction display. A warning tone also sounds and the tyre pressure warning lamp lights up in the instrument cluster.

Each tyre that is affected by a significant loss of pressure is highlighted in the pressure display.

- ▶ If the **Please correct tyre pressure** message appears in the multifunction display, check the tyre pressure on all four wheels and correct it if necessary.

- ❗ If the wheel positions on the vehicle are interchanged, the tyre pressures may be displayed for the wrong positions for a short time. This is rectified after a few minutes of driving, and the tyre pressures are displayed for the correct positions.

### Restarting the tyre pressure monitor

When you restart the tyre pressure monitor, all existing warning messages are deleted and the warning lamps go out. The monitor uses the currently set tyre pressures as the reference values for monitoring. In most cases, the tyre pressure monitor will automatically detect the new reference values after you have changed the tyre pressure. However, you can also define reference values manually as described here.

- ▶ Use the table on the inside of the fuel filler flap to ensure that the tyre pressure is set correctly in all four tyres for the current operating conditions.

Also observe the notes in the section on tyre pressures (▷ page 321).

- ▶ Make sure that the key is in position 2 (▷ page 143) in the ignition lock.
- ▶ Press the ◀ or ▶ button on the steering wheel to select the **Serv.** menu.

- ▶ Press the  or  button to select **Tyre pressure**.
- ▶ Press the  button.  
The multifunction display shows the current tyre pressure for the individual tyres or the **Tyre pressures will be displayed after a few minutes of driving** message.
- ▶ Press the  button.  
The **Use current pressures as new reference values** message appears in the multifunction display.

#### If you wish to confirm the restart:

- ▶ Press the  button.  
The **Tyre press. monitor restarted** message appears in the multifunction display.  
After you have driven for a few minutes, the system checks whether the current tyre pressures are within the specified range. The new tyre pressures are then accepted as reference values and monitored.

#### If you wish to cancel the restart:

- ▶ Press the  button.  
The tyre pressure values stored at the last restart will continue to be monitored.

#### Radio type approval for the tyre pressure monitor

Country	Radio type approval number
Brazil	1489-10-44 15
China	CMIIT-ID 2009DJ1352
Dubai	TRA, Registered No. 0014517/08
Morocco	MR5527 ANRT 2010/ 27. April 2010
Singapore	Compliance with IDA Standard DA103365
South Africa	TA-2008/1068 TA-2008/1069

## Changing a wheel

### Flat tyre

The "Breakdown assistance" section ([▷ page 305](#)) contains information and notes on how to deal with a flat tyre.

### Interchanging the wheels

#### WARNING

Interchange the front and rear wheels only if they have the same dimensions, for example size, offset, etc.

Have the tightening torque checked at a qualified specialist workshop after a wheel is changed.

The wheels could work loose if they are not tightened to a torque of **130 Nm**.

For safety reasons, Mercedes-Benz recommends that you only use wheel bolts of the correct size which have been approved for Mercedes-Benz vehicles.

**!** On vehicles fitted with a tyre pressure monitor, electronic components are located in the wheel.

Tyre-fitting tools should not be applied in the area of the valve, as this could damage the electronic components.

Only have tyres changed at a qualified specialist workshop.

Interchanging the front and rear wheels of differing dimensions can render the general operating permit invalid.

Always pay attention to the instructions and safety notices in the section on "Wheel changing and spare wheel fitting" ([▷ page 326](#)).

The wear patterns on the front and rear tyres differ, depending on the operating conditions. Interchange the wheels before a clear wear pattern has formed on the tyres. Front tyres typically wear more on the shoulders and the rear tyres in the centre.

On vehicles that have the same size front and rear wheels, you can interchange the wheels every 5000 km to 10,000 km depending on the degree of tyre wear. Maintain the direction of tyre rotation.

Clean the contact surfaces of the wheel and the brake disc thoroughly every time a wheel is interchanged. Check the tyre pressure and reactivate the tyre pressure monitor (▷ page 323) if necessary.

### Direction of rotation

Tyres with a specified direction of rotation have additional benefits, e.g. if there is a risk of aquaplaning. You will only gain these benefits if the correct direction of rotation is observed.

An arrow on the sidewall of the tyre indicates its correct direction of rotation.

You may fit the spare wheel against the direction of rotation. Observe the time restriction on use as well as the speed limitation specified on the spare wheel.

### Storing wheels

Store tyres that are not being used in a cool, dry and preferably dark place. Protect the tyres against oil, grease, petrol and diesel.

### Cleaning the wheels

#### WARNING

Do not use high-pressure cleaners with circular-jet nozzles (dirt grinders) to clean your vehicle, in particular the tyres. You could otherwise damage the tyres and cause an accident.

## Fitting a wheel

### Preparing the vehicle

- ▶ Prepare the vehicle as described (▷ page 305).
- ▶ If a trailer is coupled to the vehicle, uncouple it.
- ▶ Remove the vehicle tool kit and the jack (▷ page 302).
- ▶ Secure the vehicle to prevent it from rolling away.
- ▶ Remove the spare wheel from the spare wheel bracket (▷ page 303).

### Securing the vehicle against rolling away

- ▶ **On level ground:** place chocks or other suitable items under the front and rear of the wheel that is diagonally opposite the wheel you wish to change.
- ▶ **On downhill gradients:** place chocks or other suitable items in front of the wheels of the front and rear axle.

### Raising the vehicle

#### WARNING

If you do not position the jack correctly at the appropriate jacking point of the vehicle, the jack could tip over with the vehicle raised. There is a risk of injury.

Only position the jack at the appropriate jacking point of the vehicle. The base of the jack must be positioned vertically, directly under the jacking point of the vehicle.

The following must be observed when raising the vehicle:

- to raise the vehicle, only use the vehicle-specific jack that has been tested and approved by Mercedes-Benz. If the jack is used incorrectly, it could tip over while the vehicle is raised.
- the jack is designed only to raise and hold the vehicle for a short time while a wheel

is being changed. It is not suited for performing maintenance work under the vehicle.

- avoid changing the wheel on uphill and downhill slopes.
- before raising the vehicle, secure it from rolling away by applying the parking brake and inserting wheel chocks. Never disengage the parking brake while the vehicle is raised.
- the jack must be placed on a firm, flat and non-slip surface. On a loose surface, a large, load-bearing underlay must be used. On a slippery surface, a non-slip underlay must be used, e.g. rubber mats.
- do not use wooden blocks or similar objects as a jack underlay. Otherwise, the jack will not be able to achieve its load-bearing capacity due to the restricted height.
- make sure that the distance between the underside of the tyres and the ground does not exceed 3 cm.
- never place your hands or feet under the raised vehicle.
- never lie under the raised vehicle.
- never start the engine when the vehicle is raised.
- never open or close a door or the tailgate when the vehicle is raised.
- make sure that no persons are present in the vehicle when the vehicle is raised.



- Using wheel wrench (1), loosen the bolts on the wheel you wish to change by about one

full turn. Do not unscrew the wheel bolts completely.

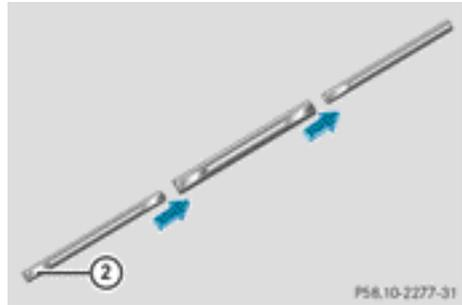

Pump lever

② Notch on pump lever

- Assemble the pump lever for the jack. It can be found with the vehicle tool kit (► page 302).

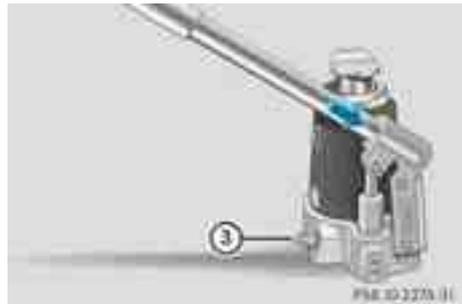

- Turn pressure release screw (3) clockwise as far as it will go using notch (2) on the pump lever. Pressure release screw (3) is closed.

**i** Do not turn pressure release screw (3) by more than one to two revolutions. Otherwise, hydraulic fluid could escape.

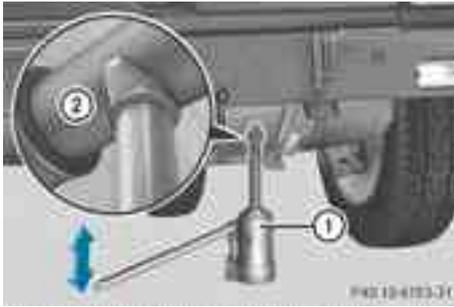

- ▶ Position jack ① on the axle carrier tube ② of the front or rear axle. Jack ① must always stand vertically, even on slopes.
- ▶ Raise the vehicle by pumping in the direction of the arrow, until the tyre is a maximum of 3 cm off the ground.

### Removing a wheel

- ❗ Do not place wheel bolts in sand or dirt. The threads of the wheel bolts and wheel hubs could otherwise be damaged when the bolts are tightened.
- ▶ Unscrew the wheel bolts.
- ▶ Remove the wheel.

### Fitting a new wheel

#### ⚠ WARNING

If a wheel hub thread is damaged, do not drive the vehicle any further. Contact a qualified specialist workshop.

#### ⚠ WARNING

Only use wheel bolts that have been designed for the wheel and the vehicle. For safety reasons, Mercedes-Benz recommends that you only use wheel bolts which have been approved for Mercedes-Benz vehicles and the respective wheel. Other wheel bolts could work loose or damage the brake system. Do not tighten the wheel bolts completely while the vehicle is still jacked up. The vehicle could topple off the jack.

Always pay attention to the instructions and safety notices in "Changing a wheel" (▷ page 325).

- ▶ Clean the wheel and wheel hub contact surfaces.
- ▶ Place the new wheel on the wheel hub and push it on.
- ▶ Tighten the wheel bolts until they are finger-tight.

### Lowering the vehicle

#### ⚠ WARNING

The wheels could work loose if the wheel nuts and bolts are not tightened to the specified tightening torque. There is a risk of accident. Have the tightening torque immediately checked at a qualified specialist workshop after a wheel is changed.

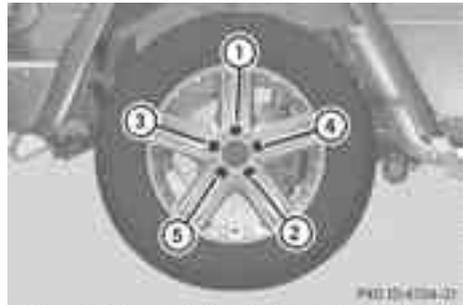

- ▶ Open the pressure release screw on the jack using the pump lever (▷ page 326) by approximately one turn.
- ▶ Place the jack to one side.
- ▶ Tighten the wheel bolts evenly in a cross-wise pattern in the sequence indicated (① to ⑤). The tightening torque must be **130 Nm**.
- ▶ Push the jack piston back in and close the drain plug.
- ▶ Use the bolts to secure the faulty wheel to the spare wheel bracket (▷ page 303).

- ▶ Stow the jack and the vehicle tools in the vehicle again.
- ▶ Check the tyre pressure of the newly fitted wheel and adjust it if necessary.  
You will find a table of tyre pressures on the inside of your vehicle's fuel filler flap.

## Wheel and tyre combinations

### General notes

**!** For safety reasons, Mercedes-Benz recommends that you only use tyres, wheels and accessories which have been approved by Mercedes-Benz specifically for your vehicle. These tyres have been specially adapted for use with the driving safety systems, such as ABS or ESP®.

Only use tyres, wheels or accessories tested and approved by Mercedes-Benz. Certain characteristics, e.g. handling, vehicle noise emissions or fuel consumption, may otherwise be adversely affected. In addition, when driving with a load, tyre dimension variations could cause the tyres to come into contact with the bodywork and axle components. This could result in damage to the tyres or the vehicle.

Mercedes-Benz accepts no liability for damage resulting from the use of tyres, wheels or accessories other than those tested and approved.

Further information about wheels, tyres and approved combinations can be obtained from any Mercedes-Benz Service Centre.

- !** Large wheels: the lower the section width for a certain wheel size, the lower the ride comfort is on poor road surfaces. Roll comfort and suspension comfort are reduced and the risk of damage to the wheels and tyres as a result of driving over obstacles increases.
- i** You will find a table of tyre pressures on the inside of your vehicle's fuel filler flap.

For further information on tyre pressure, see (▶ page 321). Check tyre pressures regularly and only when the tyres are cold.

- i** Notes on the vehicle equipment – always fit the vehicle:
  - with tyres of the same size on a given axle (left/right)
  - fit the same type of tyres on your vehicle at a given time (summer tyres, winter tyres, all-weather tyres, All Terrain tyres)

The tyre and wheel combinations listed in the tables below apply to the following models:

V1	G 500
V2	G 350 BlueTEC
V3	G 63 AMG G 65 AMG

- i** Not all wheel/tyre combinations can be mounted at the factory in all countries.

### Tyres

#### G 350 BlueTEC

#### Summer tyres

Tyres	Light-alloy wheels
265/60 R18 109 H Tyre manufacturer recommended by Mercedes-Benz: Bridgestone.	7.5J x 18 H2 ET 63

- i** You can obtain information about tyres and tyre dimensions that are not listed here at any Mercedes-Benz Service Centre.

## All-weather tyres

Tyres	Light-alloy wheels
265/70 R16 112 H M+S Tyre manufacturer recommended by Mercedes-Benz: Bridgestone.	7.5J x 16 H2 ET 63
265/60 R18 110 V M+S Tyre manufacturer recommended by Mercedes-Benz: Yokohama.	7.5J x 18 H2 ET 63

- i** You can obtain information about tyres and tyre dimensions that are not listed here at any Mercedes-Benz Service Centre.

## Spare wheel

- !** The spare wheel must be inflated to the maximum tyre pressure given in the table on the inside of the fuel filler flap.

Tyres	Light-alloy wheels
265/60 R18 110 V M+S Tyre manufacturer recommended by Mercedes-Benz: Yokohama.	7.5J x 18 H2 ET 63

- i** You can obtain information about tyres and tyre dimensions that are not listed here at any Mercedes-Benz Service Centre.

## G 500

## Summer tyres

Tyres	Light-alloy wheels
265/60 R18 109 H Tyre manufacturer recommended by Mercedes-Benz: Bridgestone.	7.5J x 18 H2 ET 63

- i** You can obtain information about tyres and tyre dimensions that are not listed here at any Mercedes-Benz Service Centre.

## All-weather tyres

Tyres	Light-alloy wheels
265/70 R16 112 H M+S Tyre manufacturer recommended by Mercedes-Benz: Bridgestone.	7.5J x 16 H2 ET 63
265/60 R18 110 V M+S Tyre manufacturer recommended by Mercedes-Benz: Yokohama.	7.5J x 18 H2 ET 63

- i** You can obtain information about tyres and tyre dimensions that are not listed here at any Mercedes-Benz Service Centre.

## Spare wheel

- !** The spare wheel must be inflated to the maximum tyre pressure given in the table on the inside of the fuel filler flap.

Tyres	Light-alloy wheels
265/60 R18 110 V M+S Tyre manufacturer recommended by Mercedes-Benz: Yokohama.	7.5J x 18 H2 ET 63

- i** The spare wheel matches the standard tyres.
- i** You can obtain information about tyres and tyre dimensions that are not listed here at any Mercedes-Benz Service Centre.

### G 63 AMG

#### Summer tyres

Tyres	Light-alloy wheels
275/50 R20 113W XL Use of snow chains not permitted. Tyre manufacturer recommended by Mercedes-Benz: Yokohama.	9.5J x 20 H2 ET 50

- i** You can obtain information about tyres and tyre dimensions that are not listed here at any Mercedes-Benz Service Centre.

#### Winter tyres

Tyres	Light-alloy wheels
265/55 R19 109H M+S Tyre manufacturer recommended by Mercedes-Benz: Dunlop.	9.5J x 19 H2 ET 50

- i** You can obtain information about tyres and tyre dimensions that are not listed here at any Mercedes-Benz Service Centre.

#### Spare wheel

- !** The spare wheel must be inflated to the maximum tyre pressure given in the table on the inside of the fuel filler flap.

Tyres	Light-alloy wheels
265/55 R19 109H M+S Tyre manufacturer recommended by Mercedes-Benz: Dunlop.	9.5J x 19 H2 ET 50

- i** You can obtain information about tyres and tyre dimensions that are not listed here at any Mercedes-Benz Service Centre.

### G 65 AMG

#### Summer tyres

Tyres	Light-alloy wheels
275/50 R20 113W XL Use of snow chains not permitted. Tyre manufacturer recommended by Mercedes-Benz: Yokohama.	9.5J x 20 H2 ET 50

- i** You can obtain information about tyres and tyre dimensions that are not listed here at any Mercedes-Benz Service Centre.

**Winter tyres**

<b>Tyres</b>	<b>Light-alloy wheels</b>
265/55 R19 109H M+S Tyre manufacturer recommended by Mercedes-Benz: Dunlop.	9.5J x 19 H2 ET 50

- i** You can obtain information about tyres and tyre dimensions that are not listed here at any Mercedes-Benz Service Centre.

**Spare wheel**

- !** The spare wheel must be inflated to the maximum tyre pressure given in the table on the inside of the fuel filler flap.

<b>Tyres</b>	<b>Light-alloy wheels</b>
265/55 R19 109H M+S Tyre manufacturer recommended by Mercedes-Benz: Dunlop.	9.5J x 19 H2 ET 50

- i** You can obtain information about tyres and tyre dimensions that are not listed here at any Mercedes-Benz Service Centre.

Useful information .....	334
Information on technical data .....	334
Genuine Mercedes-Benz parts .....	334
Vehicle electronics .....	335
Identification plates .....	336
Service products and capacities .....	337
Vehicle data .....	344
Trailer tow hitch .....	346
24 GHz radar sensor system .....	347

## Useful information

- i** This Owner's Manual describes all models, series and optional equipment for your vehicle that were available at the time of going to press. Country-specific differences are possible. Note that your vehicle may not be fitted with all features described. This is also the case for systems and functions relevant to safety.
- i** Read the information on qualified specialist workshops: (▷ page 22).

## Information on technical data

You can find current technical data on the Internet at:  
<http://www.mercedes-benz.com>

- i** The technical data was determined in accordance with EC directives. All data applies to the vehicle's standard equipment. The data may therefore differ for vehicles with optional equipment. You can obtain further information from a Mercedes-Benz Service Centre.

## Genuine Mercedes-Benz parts

### WARNING

Driving safety may be impaired if non-approved parts, tyres and wheels or safety-relevant accessories are used.

This could lead to malfunctions in safety-relevant systems, e.g. the brake system. This could cause you to lose control of your vehicle and cause an accident.

For this reason, Mercedes-Benz recommends that you use genuine Mercedes-Benz parts or parts of equal quality. Only use tyres, wheels and accessories that have been specifically approved for your vehicle.

### Environmental note

Daimler AG also supplies reconditioned assemblies and parts which are of the same quality as new parts. For these, the same warranty applies as for new parts.

- !** The use of non-approved parts could affect your vehicle's operating safety. Therefore, Mercedes-Benz recommends genuine Mercedes-Benz parts and conversion parts and accessories that have been approved for your vehicle.
- !** Airbags and seat belt tensioners, as well as control units and sensors for these restraint systems, may be installed in the following areas of your vehicle:

- doors
- door pillars
- door sills
- seats
- dashboard
- instrument cluster
- centre console

Do not install accessories such as audio systems in these areas. Do not carry out repairs or welding. You could impair the operating efficiency of the restraint systems.

Have accessories retrofitted at a qualified specialist workshop.

Mercedes-Benz tests genuine parts and conversion parts and accessories that have been specifically approved for your vehicle for their reliability, safety and suitability. Despite ongoing market research, Mercedes-Benz is unable to assess other parts. Mercedes-Benz accepts no responsibility for the use of parts that have been independently or officially approved.

In Germany, certain parts are only officially approved for installation or modification if they comply with legal requirements. This also applies to some other countries. All genuine Mercedes-Benz parts meet the approval requirements. The use of non-approved parts

may invalidate the vehicle's general operating permit.

This is the case:

- if they cause a change of the vehicle type from that for which the vehicle's general operating permit was granted
- if other road users could be endangered
- if the emission or noise levels are adversely affected

Always specify the vehicle identification number (VIN) (> page 336) and the engine number (> page 337) when ordering genuine Mercedes-Benz parts.

## Vehicle electronics

### Tampering with the engine electronics

#### WARNING

Always have work on the engine electronics and related components carried out at a qualified specialist workshop. Otherwise, the vehicle's operating safety could be affected.

- ❗ Only have work carried out on the engine electronics and its associated parts, such as control units, sensors and connector leads, at a qualified specialist workshop. Vehicle components may otherwise wear more quickly and the vehicle's operating permit may be invalidated.

### Retrofitting of two-way radios and mobile phones (RF transmitters)

#### WARNING

Incorrect retrofitting of RF transmitters can cause the vehicle electronics to malfunction. The vehicle's operating safety and thus your own safety are impaired.

Have aftermarket radio frequency transmitting equipment installed at a qualified specialist workshop.

#### WARNING

Incorrect retrofitting of RF transmitters can lead to increased electromagnetic radiation in the vehicle interior. Using an exterior aerial takes into account current scientific discussions relating to the possible health hazards that may result from electromagnetic fields. Have aftermarket radio frequency transmitting equipment installed at a qualified specialist workshop.

- ❗ The operating permit may be invalidated if the instructions for installation and use of RF transmitters are not observed.

In particular, the following conditions must be complied with:

- only approved wavebands may be used.
- the maximum permissible output in these wavebands must be complied with.
- the approved aerial positions must be complied with.

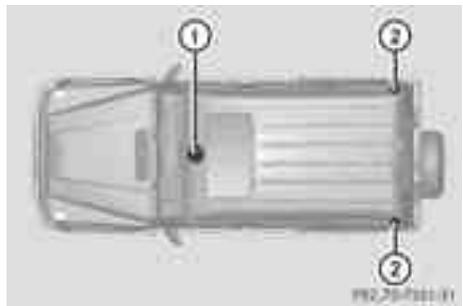

Approved aerial positions

- ① Front roof area
- ② Rear wing

- ❗ When fitting an aerial on the front roof area of vehicles with a sliding sunroof, observe the sweeping range of the roof. On the rear wing, it is recommended to position the aerial on the side of the vehicle that faces the centre of the road.

Use Technical Specification ISO/TS 21609 (Road Vehicles – "EMC guidelines for fitting aftermarket radio frequency transmitting equipment") when retrofitting RF (radio fre-

quency) transmitters. Comply with the legal requirements for add-on parts.

If your vehicle has fittings for two-way radio equipment, use the power supply or aerial connections intended for use with the basic wiring. Be sure to observe the manufacturer's additional instructions when installing.

Deviations with respect to wavebands, maximum transmission outputs or aerial positions must be approved by Mercedes-Benz.

The maximum transmission output (PEAK) at the base of the aerial must not exceed the following values:

Waveband	Maximum transmission output (PEAK)
Short wave (f < 54 MHz)	100 W
4 m waveband	30 W
2 m waveband	50 W
Trunked radio/Tetra	35 W
70 cm waveband	35 W
GSM/DCS/PCS 850/900/1800/1900	10 W
UMTS/LTE	10 W

The following can be used in the vehicle without restrictions:

- RF transmitters with a maximum transmission output of up to 100 mW
- mobile phones (GSM/DCS/PCS/UMTS/LTE)

There are no restrictions when positioning the aerial on the outside of the vehicle for the following wavebands:

- Trunked radio/Tetra
- 70 cm waveband
- GSM/DCS/PCS
- UMTS/LTE

## Identification plates

### Vehicle identification plate with vehicle identification number (VIN) and paint code number

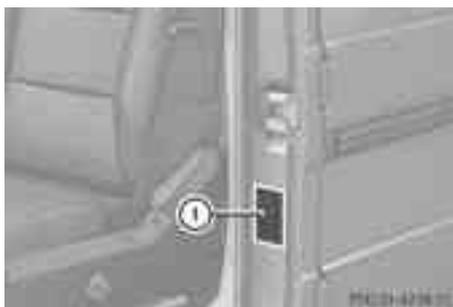

- Open the front left-hand door. You will see vehicle identification plate ①.

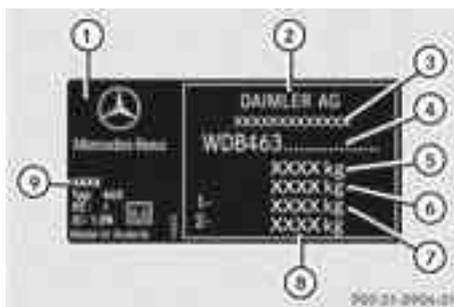

Example: vehicle identification plate

- ① Vehicle identification plate
- ② Vehicle manufacturer (Daimler AG)
- ③ EU type approval number (only for certain countries)
- ④ VIN
- ⑤ Maximum permissible gross vehicle weight (kg)
- ⑥ Maximum permissible mass of vehicle/trailer combination (kg)
- ⑦ Maximum permissible front axle load (kg)
- ⑧ Maximum permissible rear axle load (kg)
- ⑨ Paint code

**i** The data shown on the vehicle identification plate is example data. This data is different for every vehicle and can deviate

from the data shown here. You can find the data applicable to your vehicle on the vehicle's identification plate.

### Vehicle identification number (VIN)

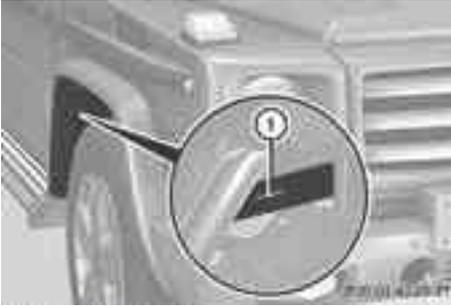

#### ① VIN

In addition to the information on the vehicle identification plate, the vehicle identification number (VIN) is also stamped onto the chassis on the right when viewed in the direction of travel.

### Engine number

The engine number is stamped onto the crankcase. You can obtain further information from any qualified specialist workshop.

## Service products and capacities

### Important safety notes

#### WARNING

When handling, storing and disposing of any service products, please observe the relevant regulations, as you could otherwise endanger yourself and others.

Keep service products away from children.

To protect your health, do not allow service products to come into contact with your eyes or open wounds. See a doctor immediately if any service product is swallowed.

#### Environmental note

Dispose of service products in an environmentally-responsible manner.

Service products include the following:

- fuels (e.g. petrol, diesel)
- exhaust gas aftertreatment additives, e.g. AdBlue®
- lubricants (e.g. engine oil, transmission oil)
- coolant
- brake fluid
- windscreen washer fluid
- climate control system refrigerant

Components and service products must be matched. Mercedes-Benz recommends that you use products tested and approved by Mercedes-Benz. They are listed in this Mercedes-Benz Owner's Manual in the appropriate section.

You can identify service products approved by Mercedes-Benz by the following inscriptions on the container:

- MB-Freigabe (e.g. MB-Freigabe 229.51)
- MB Approval (e.g. MB Approval 229.51)

Other designations or recommendations indicate a level of quality or a specification in accordance with an MB Sheet Number (e.g. MB 229.5). They have not necessarily been approved by Mercedes-Benz.

Further information can be obtained from any Mercedes-Benz Service Centre or on the Internet at <http://bevo.mercedes-benz.com>.

### Fuel

### Important safety notes

#### WARNING

Fuel is highly flammable. If you handle fuel incorrectly, there is a risk of fire and explosion.

You must avoid fire, naked flames, creating sparks and smoking. Switch off the engine

and, if applicable, the auxiliary heating before refuelling.

### WARNING

Fuels are poisonous and hazardous to health. There is a danger of injury.

Do not swallow fuel or let it come into contact with skin, eyes or clothing. Do not inhale fuel vapours. Keep fuels out of the reach of children.

If you or others come into contact with fuel, observe the following:

- Wash the fuel off any affected areas of skin with water and soap immediately.
- If you get fuel in your eyes, rinse them thoroughly with clean water immediately. Seek immediate medical attention.
- If fuel is swallowed, seek immediate medical attention. Do not induce vomiting.
- Change any clothing that has come into contact with fuel immediately.

European standard EN 228 or E DIN 51626-1 or an equivalent specification.

Fuel with this specification may contain up to 10 % ethanol.

 Do not use the following:

- E85 (petrol with 85 % ethanol)
- E100 (100 % ethanol)
- M15 (petrol with 15 % methanol)
- M85 (petrol with 85 % methanol)
- M100 (100 % methanol)
- Petrol with metallic additives
- Diesel

Do not mix these fuels with petrol, and do not use any additives. This can otherwise lead to engine damage. This does not include cleaning additives for the removal and prevention of residue build-up. Only cleaning additives recommended by Mercedes-Benz should be added to petrol, see "Additives". You can obtain further information from any Mercedes-Benz Service Centre.

 Use a filter when adding fuel from a fuel can. The fuel lines and/or the diesel injection system could otherwise be blocked by particles from the fuel can.

Usually you will find information about the fuel grade on the pump. If you cannot find the label on the petrol pump, ask the filling station staff.

 E10 fuel contains up to 10% bioethanol. Your vehicle is suitable for use with E10 fuel. You can refuel your vehicle using E10 fuel.

 As a temporary measure, if the recommended fuel is not available, you may also use unleaded petrol with an octane rating of 91 RON/82.5 MON. This may reduce engine performance and increase fuel consumption. Avoid driving at full throttle.

Information on refuelling (> page 156).

## Tank capacity

Total capacity	
All models	Approximately 96.0 l

Of which reserve fuel	
All models	Approximately 14.0 l

## Petrol (EN 228)

### Fuel grade

 Do not use diesel to refuel vehicles with a petrol engine. Even a small quantity of diesel will damage the fuel injection system.

 Only refuel using unleaded petrol with at least 95 RON/85 MON that conforms to

## AMG vehicles

**!** Only refuel using super unleaded petrol with at least 98 RON/88 MON that conforms to European standard EN 228 or an equivalent specification.

You can otherwise impair engine output or damage the engine.

**!** Premium-grade unleaded petrol with an octane rating of 95 RON/85 MON may be used as a temporary measure if the recommended fuel is not available. This may reduce engine performance and increase fuel consumption. As much as possible, avoid driving at full throttle.

**!** Regular unleaded petrol with an octane rating of 91 RON/82.5 MON may also be used as a temporary measure if the recommended fuel is not available.

Doing so results in noticeably higher fuel consumption, and the engine power output is noticeably reduced. Avoid driving at full throttle.

If only regular unleaded petrol with an octane rating of 91 RON/82.5 MON or lower is available, you must have the vehicle adapted to this fuel at a qualified specialist workshop.

**i** E10 fuel contains up to 10% bioethanol. Your vehicle is suitable for use with E10 fuel. You can refuel your vehicle using E10 fuel.

## Additives

**!** Do not refuel with low grade fuel and do not use fuel additives that have not been tested and approved for Mercedes-Benz vehicles. Otherwise the fuel system could malfunction or be damaged.

One of the major problems with low-grade fuel is the creation of carbon deposits during the process of burning fuel. Mercedes-Benz recommends that you use fuel brands that have additives.

If you use fuels without these additives for a longer period of time, there may be a build-up

of carbon deposits. These will form especially on the inlet valves and in the combustion chamber.

This could lead to engine running problems, e.g.:

- longer engine warm-up phase
- uneven idle
- engine noise
- misfiring
- loss of power

In areas where petrol with the required additives is not available, carbon deposits can build up. In this case, Mercedes-Benz recommends the use of additives that have been approved for Mercedes-Benz vehicles; see <http://bevo.mercedes-benz.com>.

The quality of the fuel available in some countries may not be sufficient. Residue could build up as a result. In such cases, and in consultation with a Mercedes-Benz Service Centre, the petrol may be mixed with the additive recommended by Mercedes-Benz (part no. A000989254510). You must observe the notes and mixing ratios specified on the container.

Consult a Mercedes-Benz Service Centre to view a list of approved products. Observe the instructions for use in the product description.

Do not mix other fuel additives with fuel. This causes unnecessary costs and could damage the engine.

## Diesel (EN 590, DIN 51628)

### Fuel grade

#### WARNING

Vehicles with a diesel engine:

If you mix diesel fuel with petrol, the flash point of this fuel mixture is lower than that of pure diesel fuel. When the engine is running, components in the exhaust system may overheat unnoticed. There is a risk of fire.

Never refuel with petrol. Never add petrol to diesel fuel.

**⚠ WARNING**

If you mix diesel fuel with petrol, the flash point of this fuel mixture is lower than that of pure diesel fuel. When the engine is running, components in the exhaust system may over-heat unnoticed. There is a risk of fire.

Never refuel with petrol. Never add petrol to diesel fuel.

**!** When refuelling, only use diesel fuel that conforms to the European standard EN 590 or is of equivalent quality. Fuel that does not conform to EN 590 can lead to increased wear as well as damage to the engine and exhaust system.

**!** Do not use the following:

- marine diesel
- heating oil
- bio-diesel
- vegetable oil
- petrol
- paraffin
- kerosene

Do not mix such fuels with diesel fuel and do not use any special additives. This can otherwise lead to engine damage. This does not include flow improver additives. For further information, see "Flow improvers".

**!** **Vehicles with a diesel particle filter:** in countries outside the EU, only refuel with low-sulphur Euro diesel with a sulphur content under 50 ppm; otherwise the emission control system could be damaged.

**!** **Vehicles without a diesel particle filter:** in countries where only diesel fuel with a high sulphur content is available, you will need to carry out your vehicle's oil change at shorter intervals. More information about the interval for oil change can be obtained from any qualified specialist workshop.

Usually you will find information about the fuel grade on the pump. If you cannot find the

label on the petrol pump, ask the filling station staff.

Information on refuelling (▷ page 157).

**Low outside temperatures**

In winter months, diesel fuel with an improved cold flow quality is available. In Europe, the EN 590 standard defines various climate-dependent temperature categories. Malfunctions can be avoided by refuelling with diesel fuel that corresponds to the climatic specifications outlined in EN 590. At unusually low outside temperatures, it is possible that the flow characteristics of the diesel fuel could be insufficient. Accordingly, diesel fuel from warmer areas may not be suitable for operation in colder climatic conditions.

**i** Further information on country-specific fuel properties can be obtained from oil companies, e.g. at filling stations.

**Flow improvers**

Flow improvers can be added to improve the cold resistance of diesel fuel. The effectiveness of flow improvers cannot be guaranteed with all fuels.

Only use flow improvers tested and approved by Mercedes-Benz. During use, please observe the information on operation.

Correct dosage and thorough mixing are decisive factors in ensuring improvement in low-temperature resistance. Under certain circumstances, an excessive dosage may actually decrease low-temperature resistance and should therefore be avoided. Follow the manufacturer's dosing instructions.

Mix the additive into the diesel in good time, before the flow characteristics of the diesel become insufficient. Otherwise, malfunctions can only be rectified by heating the entire fuel system, e.g. by parking in a heated garage.

More information about recommended flow improvers can be obtained from any qualified specialist workshop.

**AdBlue®****General notes**

AdBlue® is a non-flammable, non-toxic, colourless, odourless and water-soluble fluid.

**High outside temperatures**

If you open the AdBlue® tank cap, small amounts of ammonia vapour may be released.

Ammonia vapours have a pungent odour and are particularly irritating to:

- skin
- mucous membranes
- eyes

You may experience a burning sensation in your eyes, nose and throat, as well as coughing and watering of the eyes.

Do not inhale any ammonia vapours that may be released. Fill the AdBlue® tank only in well-ventilated areas.

**Low outside temperatures**

AdBlue® freezes at a temperature of approximately -11 °C. The vehicle is equipped with an AdBlue® preheating system at the factory. Winter operation can therefore be guaranteed even at temperatures below -11 °C.

**Additives**

**!** Only use AdBlue® in accordance with ISO 22241. Do not use additives with AdBlue® and do not dilute AdBlue® with water. This may destroy the BlueTEC exhaust gas after-treatment system.

**Purity**

**!** Impurities in AdBlue® (e.g. due to other service products, cleaning agents or dust) lead to:

- increased emission values
- damage to the catalytic converter

- engine damage
- malfunctions in the BlueTEC® exhaust gas aftertreatment system

Assuring the purity of AdBlue® is particularly important with respect to avoiding malfunctions in the BlueTEC exhaust gas aftertreatment system.

If AdBlue® is pumped out of the AdBlue® tank, e.g. during repair work, do not use this fluid to refill the tank. The purity of the fluid can no longer be guaranteed.

**Total capacity of the AdBlue® tank**

Model	Total capacity
G 350 BlueTEC	15 l

**Engine oil****General notes**

The quality of the engine oil is decisive for the function and service life of an engine. After extensive tests, Mercedes-Benz approves engine oils that correspond to the current technical standard.

Therefore, only Mercedes-Benz approved engine oils may be used in Mercedes-Benz engines.

Further information on tested and approved engine oils can be obtained from any Mercedes-Benz Service Centre. Mercedes-Benz recommends that you have the oil change carried out at a qualified specialist workshop. Mercedes-Benz approval is indicated on the oil container by the inscription "MB Approval" and the corresponding designation, e.g. MB Approval 229.51.

You can call up an overview of approved engine oils on the Internet at <http://bevo.mercedes-benz.com> by entering the designation, e.g. 229.5.

The table shows which engine oils have been approved for your vehicle.

Petrol engines	MB Approval
G 500	229.3, 229.5
G 63 AMG	229.5
G 65 AMG	229.5

Diesel engines	MB Approval
G 350 BlueTEC	228.51, 229.31, 229.51

**i** **Restriction for AMG vehicles:** only engine oils SAE 0W-40 or SAE 5W-40 may be used.

**i** If the engine oils listed in the table are not available, you may add the following engine oils until the next oil change:

- **Vehicles with a petrol engine:** MB Approval 229.1 229.3 or ACEA A3
- **Vehicles with a diesel engine:** MB Approval 229.1, 229.3, 229.5 or ACEA C3

Use only SAE 0W-40 or SAE 5W-40 engine oils for AMG vehicles.

This may only be topped up once and the quantity must not be greater than 1.0 l.

## Capacities

The following values refer to an oil change including the oil filter.

The missing values for the following model were not available at the time of going to print:

- G 63 AMG
- G 65 AMG

Vehicle model	Capacity including oil filter
G 500	9.0 l
G 350 BlueTEC	12.5 l

Vehicle model	Capacity including oil filter
G 63 AMG	
G 65 AMG	

## Additives

**!** Do not use any additives with the engine oil. This could damage the engine.

## Engine oil viscosity

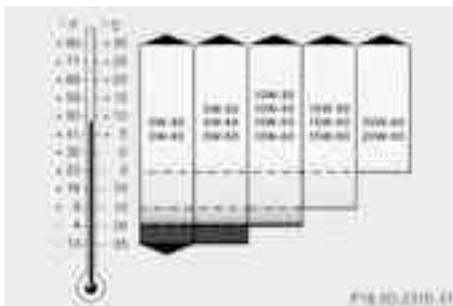

Viscosity describes the flow characteristics of a fluid. If an engine oil has a high viscosity rating, it flows slowly; the lower the viscosity, the faster it flows.

Engine oil selection is based on the respective outside temperatures and in accordance with the SAE classification (viscosity). The table shows you which SAE classifications are to be used. The low-temperature properties of engine oils can be significantly impaired during operation due to, for example, ageing or soot and fuel accretion. It is therefore strongly recommended to observe regular oil changes using an approved engine oil with the appropriate SAE classification.

## Brake fluid

### **!** WARNING

Over a period of time, the brake fluid absorbs moisture from the air; This lowers its boiling point.

If the boiling point of the brake fluid is too low, vapour pockets may form in the brake system when the brakes are applied hard (e.g. when driving downhill). This impairs braking efficiency.

You should have the brake fluid renewed at regular intervals. The brake fluid change intervals can be found in the Service Booklet.

Only use brake fluid approved by Mercedes-Benz according to MB Approval 33 1.0.

Information about approved brake fluid can be obtained at any qualified specialist workshop or on the Internet at:

<http://bevo.mercedes-benz.com>.

- i** Have the brake fluid regularly replaced at a qualified specialist workshop.

## Coolant

### Important safety notes

#### WARNING

Antifreeze is highly flammable. Fire, naked flames and smoking are prohibited when handling antifreeze.

If antifreeze comes into contact with hot engine parts, it may ignite and you could burn yourself. Do not spill any antifreeze on hot engine parts.

- !** Only add coolant that has been premixed with the desired antifreeze protection. You could otherwise damage the engine.

Further information on coolants can be found in the Mercedes-Benz Specifications for Service Products, MB Specifications for Service Products 310.1, e.g. on the Internet at <http://bevo.mercedes-benz.com>. Or contact a qualified specialist workshop.

- !** Always use a suitable coolant mixture, even in countries where high temperatures prevail.

Otherwise, the engine cooling system is not sufficiently protected from corrosion and overheating.

- !** The engine cooling system is filled with coolant, which must be renewed after 15 years or after 250,000 kilometres at the latest.

The coolant is a mixture of water and antifreeze/corrosion inhibitor. It performs the following tasks:

- anti-corrosion protection
- antifreeze protection
- raising the boiling point

If antifreeze/corrosion inhibitor is present in the correct concentration, the boiling point of the coolant will be around 130 °C.

The antifreeze/corrosion inhibitor concentration in the engine cooling system should:

- be at least 50%. This will protect the engine cooling system against freezing down to approximately -37 °C.
- not exceed 55% (antifreeze protection down to -45 °C). Heat will otherwise not be dissipated as effectively.

If the vehicle has lost coolant, top it up with equal amounts of water and antifreeze/corrosion inhibitor. Mercedes-Benz recommends an antifreeze/corrosion inhibitor in accordance with MB Specifications for Service Products 310.1.

The coolant is checked at every maintenance interval at a qualified specialist workshop.

- i** When the vehicle is first delivered, it is filled with a coolant mixture that ensures adequate antifreeze and corrosion protection.

## Washer fluid

### Important safety notes

#### WARNING

Windscreen washer concentrate is highly flammable. If it comes into contact with hot

engine components or the exhaust system it could ignite. There is a risk of fire and injury. Make sure that no windscreen washer concentrate is spilled next to the filler neck.

**!** Only use washer fluid that is suitable for plastic lamp lenses, e.g. MB SummerFit or MB WinterFit. Unsuitable washer fluid could damage the plastic lenses of the headlamps.

**!** Do not use distilled or de-ionised water in the washer fluid reservoir. Otherwise, the level sensor may be damaged.

**!** Only the washer fluids SummerFit and WinterFit can be mixed. Otherwise, the spraying nozzles could become blocked.

At temperatures above freezing:

- ▶ Fill the washer fluid reservoir with a mixture of water and washer fluid, e.g. MB SummerFit.
- ▶ Mix 1 part MB SummerFit to 100 parts water.

At temperatures below freezing:

- ▶ Fill the washer fluid reservoir with a mixture of water and washer fluid, e.g. MB WinterFit.

Adapt the mixing ratio to the outside temperature.

- ▶ Down to -10 °C: mix 1 part MB WinterFit to 2 parts water.
- ▶ Down to -20 °C: mix 1 part MB WinterFit to 1 part water.
- ▶ Down to -29 °C: mix 2 parts MB WinterFit to 1 part water.

**i** Add washer fluid concentrate, e.g. MB SummerFit or MB WinterFit, to the washer fluid all year round.

## Vehicle data

### General notes

Please note that for the specified vehicle data:

- the heights specified may vary as a result of:
  - tyres
  - load
  - condition of the suspension
  - optional equipment
- items of optional equipment increase the unladen weight and reduce the maximum payload. The unladen weight is specified in accordance with EC directive and includes:
  - driver (68 kg)
  - luggage (7 kg)
  - all fluids (fuel tank 90% full)
- vehicle-specific weight information can be found on the vehicle identification plate (▶ page 336).
- **Only for certain countries:** you can find vehicle-specific vehicle data in the COC documents (CERTIFICATE OF CONFORMITY). These documents are delivered with your vehicle.

### Dimensions and weights

#### G-Class long-wheelbase version

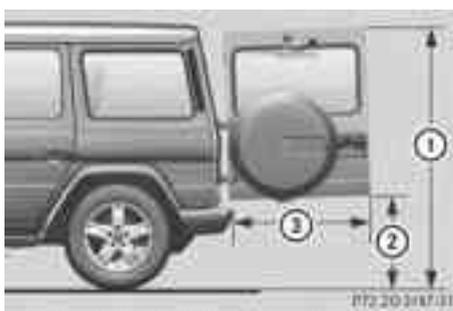

The missing values for the following models were not available at the time of going to print:

- G 63 AMG
- G 65 AMG

	All models (except AMG vehicles)	AMG vehicles
① Upper-edge clearance	1905 mm – 2005 mm	
② Lower-edge clearance	680 mm – 780 mm	
③ Range of movement	931 mm	

All models (except AMG vehicles)	
Vehicle length (ECE)	4662 mm
Vehicle width including exterior mirrors	2055 mm
Vehicle width excluding exterior mirrors	1760 mm
Maximum vehicle height	1951 mm
Wheelbase	2850 mm
Minimum ground clearance	205 mm
Unladen weight (vehicles with a petrol engine)	2642 kg
Unladen weight (vehicles with a diesel engine)	2682 kg
Maximum roof load	200 kg

## G-Class Cabriolet

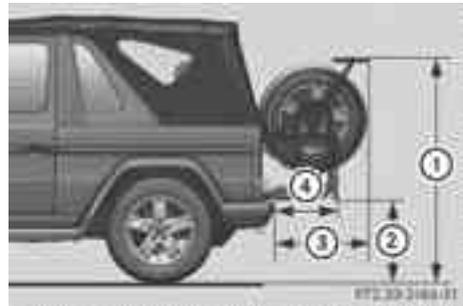

	G 500
① Upper-edge clearance (spare wheel bracket)	1580 mm – 1680 mm
② Lower-edge clearance (tailgate)	1050 mm – 1070 mm
③ Range of movement (spare wheel bracket)	750 mm
④ Range of movement (tailgate)	500 mm

G 500	
Vehicle length (ECE)	4257 mm
Vehicle width including exterior mirrors	2055 mm
Vehicle width excluding exterior mirrors	1760 mm
Maximum vehicle height	1951 mm
Wheelbase	2400 mm
Minimum ground clearance	205 mm
Unladen weight	2492 kg

## Trailer tow hitch

### Mounting dimensions

#### WARNING

Only have a trailer tow hitch retrofitted at a qualified specialist workshop.

**!** If you have a trailer tow hitch retrofitted, changes to the engine cooling system may be necessary, depending on the vehicle type.

If you have a trailer tow hitch retrofitted, observe the anchorage points on the chassis frame.

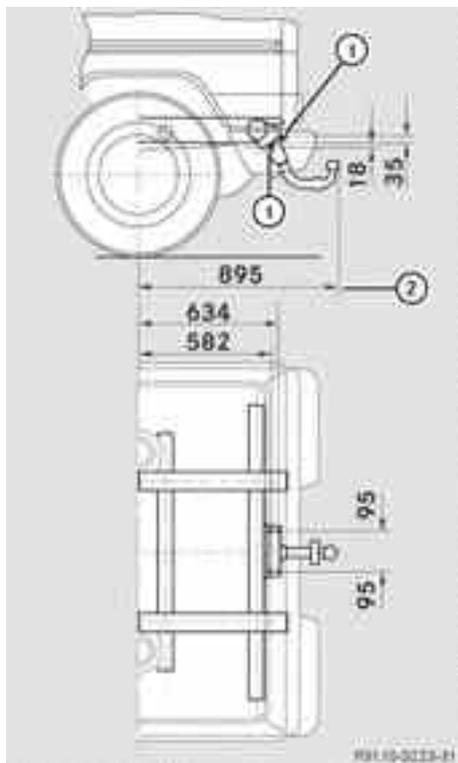

Example: anchorage points for the trailer tow hitch

- ① Anchorage points
- ② Overhang dimension

For trailer tow hitches fitted at the factory, the overhang dimension including protective covering is 895 mm.

## Trailer loads

### G-Class long-wheelbase version (all models)

Permissible trailer load, unbraked	750 kg
Permissible trailer load, braked (at a minimum gradient-climbing capability of 12% from a standstill)	3500 kg
Maximum drawbar nose-weight (the drawbar noseweight is not included in the trailer load)	140 kg
Permissible rear axle load when towing a trailer	1900 kg
Maximum gross vehicle weight when towing a trailer	6700 kg

### G-Class Cabriolet

Permissible trailer load, unbraked	750 kg
Permissible trailer load, braked (at a minimum gradient-climbing capability of 12% from a standstill)	2850 kg
Maximum drawbar nose-weight (the drawbar noseweight is not included in the trailer load)	115 kg
Permissible rear axle load when towing a trailer (the drawbar nose-weight is not included in the towing weight)	1800 kg
Maximum gross vehicle weight when towing a trailer	5700 kg

## 24 GHz radar sensor system

The 24 GHz radar sensor system requires separate approval for each country.

Maintain the minimum distance from radio telescope facilities.

The current country overview can be obtained from a Mercedes-Benz Service Centre or on the Internet at: <http://www.mercedes-benz.de/betriebsanleitung>.



## **Internet**

Further information about Mercedes-Benz vehicles and about Daimler AG can be found on the following websites:

<http://www.mercedes-benz.com>

<http://www.daimler.com>

## **Editorial office**

You are welcome to forward any queries or suggestions you may have regarding this Owner's Manual to the technical documentation team at the following address:

Daimler AG, HPC: R822,  
D-70546 Stuttgart, Germany

Not to be reprinted, translated or otherwise reproduced, in whole or in part, without written permission of Daimler AG.

As at 16.12.2011

Nur für internen Gebrauch / For internal use only



HLI000000722

Order no. 6515 4141 02 Part no. HLI 000 00 00 722 Edition ÄJ 2012-Ma

Nur für internen Gebrauch / For internal use only