

2003 VOLVO V70



This manual deals with the operation and care of your Volvo.



Welcome to the worldwide family of Volvo owners. We trust that you will enjoy many years of safe driving in your Volvo, an automobile designed with your safety and comfort in mind. To help ensure your satisfaction with this vehicle, we encourage you to familiarize yourself with the equipment descriptions, operating instructions and maintenance requirements/recommendations in this manual. We also urge you and your passengers to wear seat belts at all times in this or any other automobile. And, of course, please do not operate a vehicle if you may be affected by alcohol, medication or any impairment that could hinder your ability to drive.

Your Volvo is designed to meet all applicable safety and emission standards, as evidenced by the certification labels attached to the driver's door opening and on the left wheel housing in the engine compartment.

For further information please contact your retailer, or:

In the USA:

In Canada:

Volvo Cars of North America Volvo Canada Ltd.
Customer Relations 175 Gordon Baker Road
P.O. Box 914 North York, Ontario M2H 2N7
Rockleigh, New Jersey 07647-0914 800-663-8255
800-458-1552

We also invite you to visit our Home Page on the Internet at:

<http://www.volvocars.com>

Contents

Contents

[Chapter 1 - Safety](#)

[Chapter 2 - Instruments, switches and controls](#)

[Chapter 3 - Climate control system](#)

[Chapter 4 - Interior](#)

[Chapter 5 - Keys, Locks, Alarm](#)

[Chapter 6 - Starting and driving](#)

[Chapter 7 - Wheels and tires](#)

[Chapter 8 - Maintenance/Serviceing](#)

[Chapter 9 - Specifications](#)

[Chapter 10 - Audio systems](#)

[HomeLink® Universal Transceiver \(option\)](#)

[Index](#)

[Back Cover](#)

General information

Shiftlock

When your car is parked, the gear selector is locked in the (P)ark position. To release the selector from this position, turn the ignition key to position II (or start the engine), depress the brake pedal, press the button on the front of the gear selector knob and move the selector from (P)ark.

Keylock

This means that when you switch off the ignition, the gear selector must be in the (P)ark position before the key can be removed from the ignition switch.

Anti-lock Brake System (ABS)

The ABS system in your car performs a self-diagnostic test when the vehicle first reaches the speed of approximately 12 mph (20 km/h). The brake pedal will pulsate several times and a sound may be audible from the ABS control module. This is normal.

Fuel filler door

Press the button on the light switch panel (see [page 34](#)) when the car is at a standstill to unlock the fuel filler door. Please note that the fuel filler door will remain unlocked until the car begins to move forward. An audible click will be heard when the fuel filler door relocks.

Fuel filler cap

After refueling, close the fuel filler cap by turning it clockwise until it *clicks* into place. If this cap is not closed tightly or if the engine is running when the car is refueled, the Malfunction Indicator Lamp ("Check Engine" light) may indicate a fault.

Important

Before you operate your car for the first time, please familiarize yourself with the new-engine oil consumption information on [page 135](#). You should also be familiar with the information in the chapters one, two and four of this manual.

Information contained in the balance of the manual is extremely useful and should be read after operating the vehicle for the first time.

The manual is structured so that it can be used for reference. For this reason, it should be kept in the car for ready access.

Do not export your Volvo to another country before investigating that country's applicable safety and exhaust emission requirements. In some cases it may be difficult or impossible to comply with these requirements. Modifications to the emission control system(s) may render your Volvo not certifiable for legal operation in the U.S., Canada and other countries.

All information, illustrations and specifications contained in this manual are based on the latest product information available at the time of publication. Please note that some vehicles may be equipped differently, depending on special legal requirements and that optional equipment described in this manual may not be available in all markets.

Volvo reserves the right to make model changes at any time, or to change specifications or design, without notice and without incurring obligation.

CALIFORNIA Proposition 65 Warning

WARNING! Engine exhaust, some of its constituents, and certain vehicle components contain or emit chemicals known to the state of California to cause cancer, and birth defects or other reproductive harm. In addition, certain fluids contained in vehicles and certain products of component wear contain or emit chemicals known to the State of California to cause cancer, and birth defects or other reproductive harm.

Volvo and the environment

Volvo is committed to the well being of our customers. As a natural part of this commitment, we care about the

environment in which we all live. Caring for the environment means an everyday involvement in reducing our environmental impact.

Volvo's environmental activities are based on a holistic view, which means we consider the overall environmental impact of a product throughout its complete life cycle. In this context, design, production, product use, and recycling are all important considerations.

In production, Volvo has partly or completely phased out several chemicals including freons, lead chromates, naphthanates, asbestos, mercury and cadmium; and reduced the amount of chemicals used in our plants 50% since 1991.

In use, Volvo was the first in the world to introduce into production a three-way catalytic converter with a Lambda sond, now called oxygen sensor, in 1976. The current version of this highly efficient system reduces emissions of harmful substances (CO, HC, NOx) from the exhaust pipe by approximately 95% and the search to eliminate the remaining emissions continues. Volvo is the only automobile manufacturer to offer CFC-free retrofit kits for the air conditioning system for all models as far back as the M/Y 1975 240. Advanced electronic engine controls, refined purification systems and cleaner fuels are bringing us closer to our goal.

After Volvo cars and parts have fulfilled their use, recycling is the next critical step in completing the life cycle. The metal content is about 75% of the total weight of a car, which makes the car among the most recycled industrial products. In order to have efficient and well controlled recycling, many Volvo variants have printed dismantling manuals, indicating the weight and material of individual components. For Volvo, all homogeneous plastic parts weighing more than 1.7 oz. (50 grams) are marked with international symbols that indicate how the component is to be sorted for recycling.

In addition to continuous environmental refinement of conventional gasoline-powered internal combustion engines, Volvo is actively looking at advanced technology alternative-fuel vehicles.

When you drive a Volvo, you become our partner in the work to lessen the car's impact on the environment.

To reduce your vehicle's environmental impact, you can:

- Maintain proper air pressure in your tires. Tests have shown decreased fuel economy with improperly inflated tires
- Follow the recommended maintenance schedule
- Drive at a constant speed
- See an authorized Volvo retailer as soon as possible for inspection if the check engine (malfunction indicator) lamp illuminates, or stays on after the vehicle has started
- Properly dispose of any vehicle related waste such as used motor oil, used batteries, brake pads, etc.
- When cleaning your car, use Volvo's own car care products, all of which have systematically been adapted to the environment

Prem-Air®

On the surface of the radiator in the engine compartment, there is a special coating called Prem-Air®. Prem-Air® works as a catalytic converter, converting most of the ozone passing through the radiator into oxygen, thereby reducing harmful ground-level ozone.

For additional information regarding the environmental activities in

which Volvo Cars of North America, LLC. and Volvo Car of Canada, Ltd. are involved, visit our Internet Home Page at:

<http://www.volvocars.com>



[Top of Page](#)

2003
VOLVO
V70

Chapter 1 - Safety

pg. 1 Safety

Not wearing a seat belt is like believing "It'll never happen to me!" Volvo, the inventor of the three-point seat belt, urges you and all adult occupants of your car to wear seat belts and ensure that children are properly restrained, using an infant, car or booster seat determined by age, weight and height. Volvo also believes no child should sit in the front seat of a car.

Fact: In every state and province, some type of child-restraint legislation has been passed. Additionally, most states and provinces have already made it mandatory for occupants of a car to use seat belts.

So, urging you to "buckle up" is not just our recommendation - legislation in your state or province may mandate seat belt usage. The few seconds it takes to buckle up may one day allow you to say, "It's a good thing I was wearing my seat belt."

[Seat belts](#) [2](#)

[Center head restraint](#) [3](#)

[Front airbags \(SRS\)](#) [4](#)

[Side impact airbags \(SIPS\)](#) [8](#)

[Volvo Inflatable Curtain \(VIC\)](#) [9](#)

[Whiplash Protection System \(WHIPS\)](#) [10](#)

[Child safety](#) [11](#)

[Occupant safety](#) [17](#)

[Brake system](#) [18](#)

[Anti-lock Brake System \(ABS\)](#) [19](#)

[Stability Traction Control \(STC\)](#) [20](#)

[Dynamic Stability Traction Control \(DSTC\)](#) [20](#)

pg. 2 Seat belts

Seat belts

Always fasten the seat belts before you drive or ride. A chime will sound several times if the driver's seat belt is not fastened.

To buckle:

Pull the belt out far enough to insert the latch plate into the receptacle until a distinct click is heard. The seat belt retractor is normally "unlocked" and you can move freely, provided that the shoulder belt is not pulled out too far. The retractor will lock up as follows:

- if the belt is pulled out rapidly
- during braking and acceleration
- if the vehicle is leaning excessively
- when driving in turns

For the seat belt to provide maximum protection in the event of an accident, it must be worn correctly. When wearing the seat belt remember:

- The belt should not be twisted or turned.
- The lap belt must be positioned low on the hips (not pressing against the abdomen).

Make sure that the shoulder belt is rolled up into its retractor and that the shoulder and lap belts are taut.

Before exiting the car, check that the seat belt retracts fully after being unbuckled. If necessary, guide the belt back into the retractor slot.

NOTE: Legislation in your state or province may mandate seat belt usage.

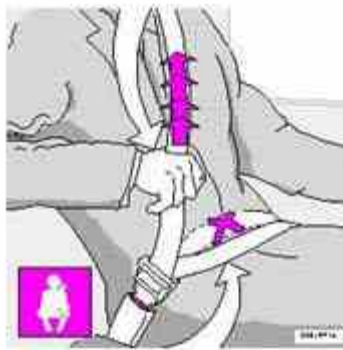

*Adjusting shoulder belt
Lap portion of the belt should sit low*

Child seats: Please refer to [page 14](#) for information on securing child seats with the seat belts.



During pregnancy

Pregnant women should always wear seat belts. Remember that the belt should always be positioned in such a way as to avoid any possible pressure on the abdomen. The lap portion of the belt should be located low, as shown in the above illustration.

pg. 3 Seat belts, Center head restraint

WARNING!

- Never use a seat belt for more than one occupant.
- Never wear the shoulder portion of the belt under the arm, behind the back or otherwise out of position. Such use could cause injury in the event of an accident.
- As the seat belts lose much of their strength when exposed to violent stretching, they should be replaced after any collision, even if they appear to be undamaged.
- Never repair the belt on your own; have this work done by an authorized Volvo retailer only.
- Any device used to induce slack into the shoulder belt portion of the three-point belt system will have a detrimental effect on the amount of protection available to you in the event of a collision.
- The seat back should not be tilted too far back. The shoulder belt must be taut in order to function properly.
- Do not use child safety seats or child booster cushions/backrests in the front passenger's seat. We also recommend that children who have outgrown these devices sit in the rear seat with the seat belt properly fastened.

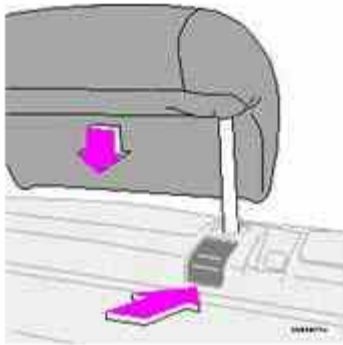

Adjust head restraint height

Center head restraint (rear)

The center head restraint can be adjusted according to the passenger's height. The restraint should be carefully adjusted to support the occupant's head.

To raise, lift up to desired position. To lower the center head restraint, press the release button behind the right-hand support while pressing down the head restraint to the desired position.

WARNING!

- As its name implies, SRS is designed to be a **SUPPLEMENT** to - not a replacement for - the three-point belt system. For maximum protection, wear seat belts at all times. Be aware that no system can prevent all possible

injuries that may occur in an accident.

- When installing any accessory equipment, make sure that the SRS system is not damaged. Do not attempt to service any component of the SRS yourself. Attempting to do so may result in serious personal injury. If a problem arises, take your car to the nearest authorized Volvo retailer for inspection as soon as possible.

pg. 4 Front airbags - SRS



Driver's side airbag - in steering wheel hub

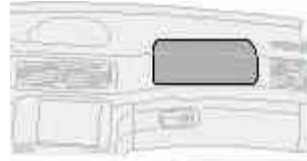

Passenger's side airbag - above glove compartment

As an enhancement to the three-point seat belt system, your Volvo is equipped with a Supplemental Restraint System (SRS). The Volvo SRS consists of an airbag (2) on both the driver's and passenger's sides and seat belt tensioners in both front door pillars (4). The system is designed to supplement the protection provided by the three-point seat belt system. All three rear seat belts are also equipped with tensioners.

The SRS system is indicated by the "SRS" embossed on the steering wheel pad and above the glove compartment, and by decals on both sun visors and on the front and far right side of the dash.

The airbags are folded and located in the steering wheel hub and above the glove compartment. They are designed to deploy during certain frontal or front-angular collisions, impacts, or decelerations, depending on the crash severity, angle, speed and object impacted. The airbags may also deploy in certain non-frontal collisions where rapid deceleration occurs.

The airbag system includes gas generators (1) surrounded by the airbags (2) and front seat belt tensioners for both of the front seats (4). To deploy the system, the sensor (3) activates the gas generators causing the airbags to be inflated with nitrogen gas. As the movement of the seats' occupants compresses the airbags, some of the gas is expelled at a controlled rate to provide better cushioning. Both seat belt tensioners also deploy, minimizing any seat belt slack.

The entire process, including inflation and deflation of the airbags, takes approximately two-tenths of a second.

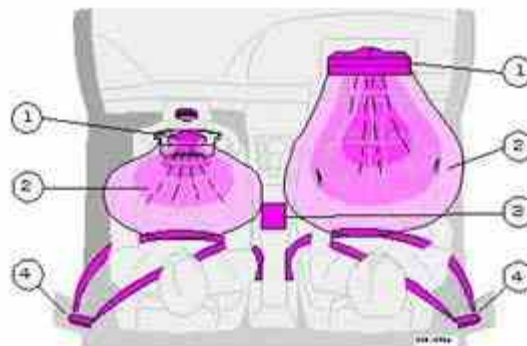

WARNING!

As its name implies, SRS is designed to be a SUPPLEMENT to -not a replacement for - the three-point belt system. For maximum protection, wear seat belts at all times. Be aware that no system can prevent all possible injuries that may occur in an accident.

- When installing any optional equipment, make sure that the SRS system is not damaged. Do not attempt to service any component of the SRS yourself. Attempting to do so may result in serious personal injury. If a problem arises, take your car to the nearest authorized Volvo retailer for inspection as soon as possible.

pg. 5 Front airbags - SRS



A self-diagnostic system incorporated in the sensor monitors the SRS. This system does not, however, monitor the Side Impact Protection System (SIPS) airbags. If a fault is detected, the warning light will illuminate. The light is included in the warning/indicator light cluster in the instrument panel. Normally, the SRS warning lamp should light up when the ignition key is turned to positions I, II or III and should go out after 7 seconds or when the engine is started. Check that this light is functioning properly every time the car is started.

The following items are monitored by the self-diagnostic system:

- Sensor unit
- Cable harness
- Gas generator igniters

WARNING!

- Never drive an SRS equipped car with your hands on the steering wheel pad / airbag housing.
- No objects, accessory equipment or stickers may be placed on, attached to or installed near the SRS cover in the center of the steering wheel, the SRS cover above the glove compartment or the area affected by airbag deployment.
- If the SRS warning light stays on after the engine has started or if it comes on while you are driving, drive the car to the nearest authorized Volvo retailer for inspection as soon as possible.



Above: Sample label found on all tensioner-equipped seat belts. The label is sewn into the belt near its lower anchorage point.



Above: Sample SRS service decal, which can be found on the edge of the left rear door.

There is no maintenance to perform on the SRS yourself. The month and year shown on the decal on the door pillar indicate when you should contact your Volvo retailer for specific servicing or replacement of airbags and seat belt tensioners. This service must be performed by an authorized Volvo retailer.

Should you have any questions about the SRS system, please contact your authorized Volvo retailer or Volvo Customer Support:

In the USA:

Volvo Cars of North America
 Customer Relations
 P.O. Box 914
 Rockleigh, New Jersey 07647-0914
 800-458-1552

In Canada:

Volvo Cars of Canada Ltd.
 175 Gordon Baker Road
 North York, Ontario M2H 2N7



SRS text on outside of both sun visors



SRS text on inside of both sun visors



SRS text on the passenger's dash

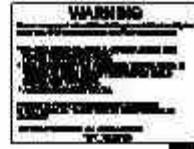

SRS decal at far right of instrument panel

WARNING!

Do not use child safety seats or child booster cushions/backrests in the front passenger's seat. We also recommend that occupants under 4 feet 7 inches (140 cm) in height who have outgrown these devices sit in the rear seat with the seat belt fastened.

NOTE: Deployment of SRS components occurs only one time during an accident. In a collision where deployment occurs, the air bags and seat belt tensioners activate. Some noise occurs and a small amount of powder is released. The release of the powder may appear as smoke-like matter. This is a normal characteristic and does not indicate fire.

NOTE: Volvo's dual-threshold airbags use special sensors that are integrated with the front seat buckles. The point at which the air bag deploys is determined by whether or not the seat belt is being used, as well as the severity of the collision. Collisions can occur where only one of the airbags deploys.

NOTE: Volvo's dual-stage airbags: If the impact is less severe, but severe enough to present a clear injury risk, the dual-stage airbags are triggered at just 70% of its total capacity. If the impact is more severe, the dual-stage airbags are triggered with full capacity.

WARNING!

- Children must never be allowed in the front passenger seat. Volvo recommends that ALL occupants (adults and children) shorter than 4 feet 7 inches (140 cm) be seated in the back seat of any vehicle with a passenger-side front airbag. See [page 14](#) for guidelines.
- Occupants in the front passenger's seat must never sit on the edge of the seat, sit leaning toward the instrument panel or otherwise sit out of position. The occupant's back must be as upright as comfort allows and be against the seat back with the seat belt properly fastened.
- Feet must be on the floor, e.g. not on the dash, seat or out of the window.
- No objects or accessory equipment, e.g. dash covers, may be placed on, attached to or installed near the SRS hatch (the area above the glove compartment) or the area affected by airbag deployment (see illustration on [page 4](#)).
- There should be no loose articles, e.g. coffee cups, on the floor, seat or dash area.
- Never try to open the SRS cover on the steering wheel or the passenger side dash. This should only be done by an authorized Volvo service technician.
- Failure to follow these instructions can result in injury to the vehicle occupants.

NOTE: The information on this page does not pertain to the Side Impact Protection System airbags.

When are the airbags deployed?

The SRS system is designed to deploy during certain frontal or front-angular collisions, impacts, or decelerations, depending on the crash severity, angle, speed and object impacted. The SRS sensor is designed to react to both the impact of the collision and the inertial forces generated by it and to determine if the intensity of the collision is sufficient for the airbags to be deployed.

WARNING!

The SRS is designed to help prevent serious injury. Deployment occurs very quickly and with considerable force. During normal deployment and depending on variables such as seating position, one may experience abrasions, bruises, swellings, or other injuries as a result of airbag(s) deployment.

If the airbags have been deployed, we recommend the following:

- Have the car towed to an authorized Volvo retailer. Never drive with the airbags deployed.
- Have an authorized Volvo retailer replace the SRS system components.
- Use only new, Genuine Volvo Parts when replacing SRS components (airbags, seat belts, tensioners, etc.).

When are the airbags NOT deployed?

Not all frontal collisions activate the SRS system. If the collision involves a nonrigid object (e.g., a snow drift or bush), or a rigid, fixed object at a low speed, the SRS system will not necessarily deploy. Front airbags do not normally deploy in a side impact collision, in a collision from the rear or in a rollover situation. The amount of damage to the bodywork does not reliably indicate if the airbags should have deployed or not.

Seat belts - the heart of the Volvo safety system

The heart of the Volvo safety system is the **three-point seat belt** (a Volvo invention)! In order for the SRS system to provide the protection intended, seat belts must be worn at all times by everyone in the car. **The SRS system is a supplement to the seat belts.**

WARNING!

If your car has been subjected to flood conditions (e.g. soaked carpeting/standing water on the floor of the vehicle) or if your car has become flood-damaged in any way, do not attempt to start the vehicle or put the key in the ignition before disconnecting the battery (see below). This may cause airbag deployment which could result in personal injury. Have the car towed to an authorized Volvo retailer for repairs.

Automatic transmission:

Before attempting to tow the car, use the following procedure to override the shiftlock system to move the gear selector to the neutral position.

- Switch off the ignition for at least 10 minutes and disconnect the battery
- Wait at least one minute
- Insert the key in the ignition and turn it to position II
- Press firmly on the brake pedal.
- Move the gear selector from (P)ark to the (N)eutral position.

WARNING!

Never drive with the airbags deployed. The fact that they hang out can impair the steering of your car. Other safety systems can also be damaged. The smoke and dust formed when the airbags are deployed can cause skin and eye irritation in the event of prolonged exposure.

pg. 8 Side impact airbags (SIPS)



*SIPS airbag **

SIPS airbag (front seats only)

As an enhancement to the structural Side Impact Protection System built into your car, the car is also equipped with Side Impact Protection System (SIPS) airbags. The SIPS airbag system consists of airbag modules built into the sides of both front seat backrests (1), wires (2) and gas generators/sensor units (3). The SIPS airbag system is designed to help increase occupant protection in the event of certain side impact collisions. The SIPS airbags are designed to deploy only during certain side-impact collisions, depending on the crash severity, angle, speed and point of impact. The airbags are not designed to deploy in all side impact situations.

WARNING!

- The SIPS airbag system is a supplement to the Side Impact Protection System and the three-point seat belt system. It is not designed to deploy during collisions from the front or rear of the car or in rollover situations.
- The use of seat covers on the front seats may impede SIPS airbag deployment.
- No objects, accessory equipment or stickers may be placed on, attached to or installed near, the SIPS airbag system or in the area affected by SIPS airbag deployment (see illustration below).
- Never try to open or repair any components of the SIPS airbag system. This should be done only by an authorized Volvo service technician.
- In order for the SIPS airbag to provide its best protection, both front seat occupants should sit in an upright position with the seat belt properly fastened.

NOTE: SIPS airbag deployment (one airbag) occurs only on the side of the vehicle affected by the impact.

*A SIPS airbag warning decal is also located at the end of the instrument panel on the driver's side of the car.

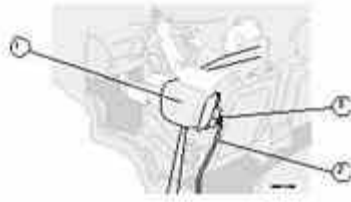

1 - Airbag, 2 - wire, 3 - gas generator/sensor unit

WARNING!

- Never drive with the airbags deployed. The fact that they hang out can impair the steering of your car. Other safety systems can also be damaged. The smoke and dust formed when the airbags are deployed can cause skin and eye irritation in the event of prolonged exposure.
- If your car has been subjected to flood conditions (e.g. soaked carpeting/ standing water on the floor of the vehicle) or if your car has become flood-damaged in any way, do not attempt to start the vehicle or put the key in the ignition before disconnecting the battery. This may cause airbag deployment which could result in personal injury. Have the car towed to an authorized Volvo retailer for repairs.

pg. 9 Volvo Inflatable Curtain (VIC)

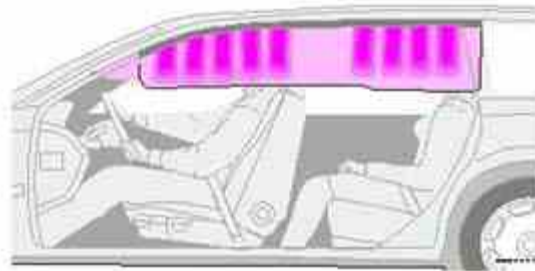

Volvo Inflatable Curtain (VIC)

This system consists of inflatable curtains located along the sides of the roof liners, stretching from the center of both front side windows to the rear edge of the rear side door windows. It is designed to help protect the heads of the occupant of the front seat and the occupant of the outboard rear seat position in certain side impact collisions.

NOTE: IC system deployment occurs only on the side of the vehicle affected by the impact.

In certain side impacts, **BOTH** the Inflatable Curtain (IC) and the Side Impact Airbag System (SIPS-bag) will deploy, whereas, in some cases, **ONLY** the Inflatable Curtain (IC) will deploy. In cases where **BOTH** the IC and the SIPS-bag deploy, deployment will occur simultaneously.

If the inflatable curtain deploys, it remains inflated for approximately 3 seconds.

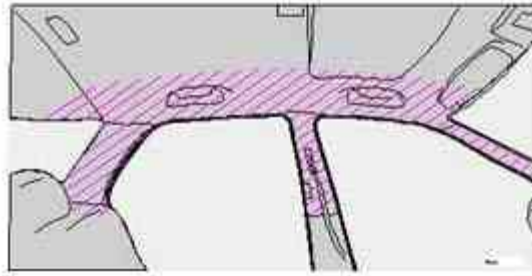

WARNING!

- The IC system is a supplement to the Side Impact Protection System. It is not designed to deploy during collisions from the front or rear of the car or in rollover situations.
- Never try to open or repair any components of the IC system. This should be done only by an authorized Volvo service technician.
- The inflatable curtains are designed to deploy only during certain side-impact collisions, depending on the crash severity, angle, speed and impact. The inflatable curtains are not designed to deploy in all side impact situations.
- In order for the IC to provide its best protection, both front seat occupants and both outboard rear seat occupants should sit in an upright position with the seat belt properly fastened; adults using the seat belt and children using the proper child restraint system. Only adults should sit in the front seats. Children must never be allowed in the front passenger seat. See [page 14](#) for guidelines. Failure to follow these instructions can result in injury to the vehicle occupants.
- When the rear seat backrest(s) are folded down, the car should not be loaded to a level higher than 2 in. (5 cm) below the upper edge of the rear passenger door windows. Objects placed higher than this level could impede the function of the inflatable curtain.

pg. 10 Whiplash Protection System (WHIPS)

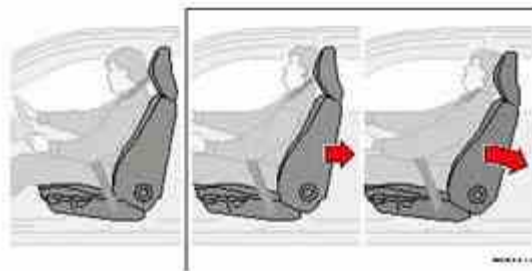

Whiplash Protection System (WHIPS) - front seats only

The WHIPS system consists of specially designed hinges and brackets on the front seat backrests and head restraints designed to help absorb some of the energy generated in a collision from the rear ("rear-ended").

In the event of a collision of this type, the hinges and brackets of the front seat backrests are designed to change position slightly to allow the backrest/head restraint to help support the occupant's head before moving slightly

rearward. This movement helps absorb some of the forces that could result in the whiplash effect.

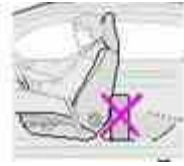

Do not wedge boxes, suitcases, etc. behind front seats

WARNING!

- Any contact between the front seat backrests and the folded rear seat could impede the function of the WHIPS system. If the rear seat is folded down, the occupied front seats must be adjusted forward so that they do not touch the folded rear seat.
- Boxes, suitcases, etc. wedged behind the front seats (see illustration above) could impede the function of the WHIPS system.
- The WHIPS system is designed to supplement the other safety systems in your car. For this system to function properly, the three-point seat belt must be worn. Please be aware that no system can prevent all possible injuries that may occur in an accident.
- If your car has been involved in a collision, the front seat backrests must be inspected by an authorized Volvo retailer even if the seats appear to be undamaged. Certain components in the WHIPS system may need to be replaced. Do not attempt to service any component in the WHIPS system yourself.
- If the rear seat backrests are folded down, cargo must be secured to prevent it from sliding forward against the front seat backrests in the event of a collision from the rear. This could interfere with the action of the WHIPS system.
- The WHIPS system is designed to function in certain collisions from the rear, depending on the crash severity, angle and speed.
- Occupants in the front seats must never sit out of position. The occupant's back must be as upright as comfort allows and be against the seat back with the seat belt properly fastened.



[Contents](#) | [Top of Page](#)

2003
VOLVO
V70

Chapter 2 - Instruments, switches and controls

pg. 23 Instruments, switches and controls

<u>Interior</u>	<u>24</u>
<u>Exterior</u>	<u>25</u>
<u>Instruments</u>	<u>26</u>
<u>Instrument panel</u>	<u>27</u>
<u>Indicator and warning lights</u>	<u>28</u>
<u>Text information window</u>	<u>30</u>
<u>Switches in the center console</u>	<u>31</u>
<u>Trip computer</u>	<u>32</u>
<u>Cruise control</u>	<u>33</u>
<u>Light switch panel</u>	<u>34</u>
<u>Steering wheel adjustment, Ignition switch/Steering wheel lock</u>	<u>35</u>
<u>Turn signals</u>	<u>36</u>
<u>Windshield wipers/washers</u>	<u>37</u>
<u>Warning flashers, heated mirrors/rear window, heated front seats</u>	<u>38</u>
<u>Parking brake, auxiliary socket/ashtrays</u>	<u>39</u>
<u>Electrically operated windows</u>	<u>40</u>
<u>Rearview/sideview mirrors</u>	<u>41</u>
<u>Sun roof</u>	<u>42</u>

pg. 24 Interior

Power windows	40
Sideview mirror controls	41
Locking and unlocking the car	76
Alarm	80

Glove compartment	59
-------------------------	----

Center console switches	31
Parking brake	39
Manual transmission	89
Automatic transmission	90

Adjusting head restraint	3
Integrated booster cushions	12
Folding rear seat	63
Child safety locks	82

Heated seats (option)	28
Power seat adjustment	56
Cleaning upholstery	128

pg. 25 Exterior

Sun roof (option)	42
-------------------------	----

Paint touch-up	126
Washing the car	127

Fuel filler door	86
Refueling	86
Economical driving	95

Replacing a low beam	120
Replacing a high beam	120
Replacing a parking light	121
Replacing a front turn signal	121
Replacing a front fog light	123
Replacing a headlight wiper	140

Replacing a back-up light	122
Replacing a brake light	122
Replacing a tail light	122
Replacing a rear turn signal	122
Replacing a rear fog light	122
Replacing license plate lights	124

Brake system	18
Tires	108
Wheels	108
Spare tire	110
Changing wheels	112

pg. 26 Instruments

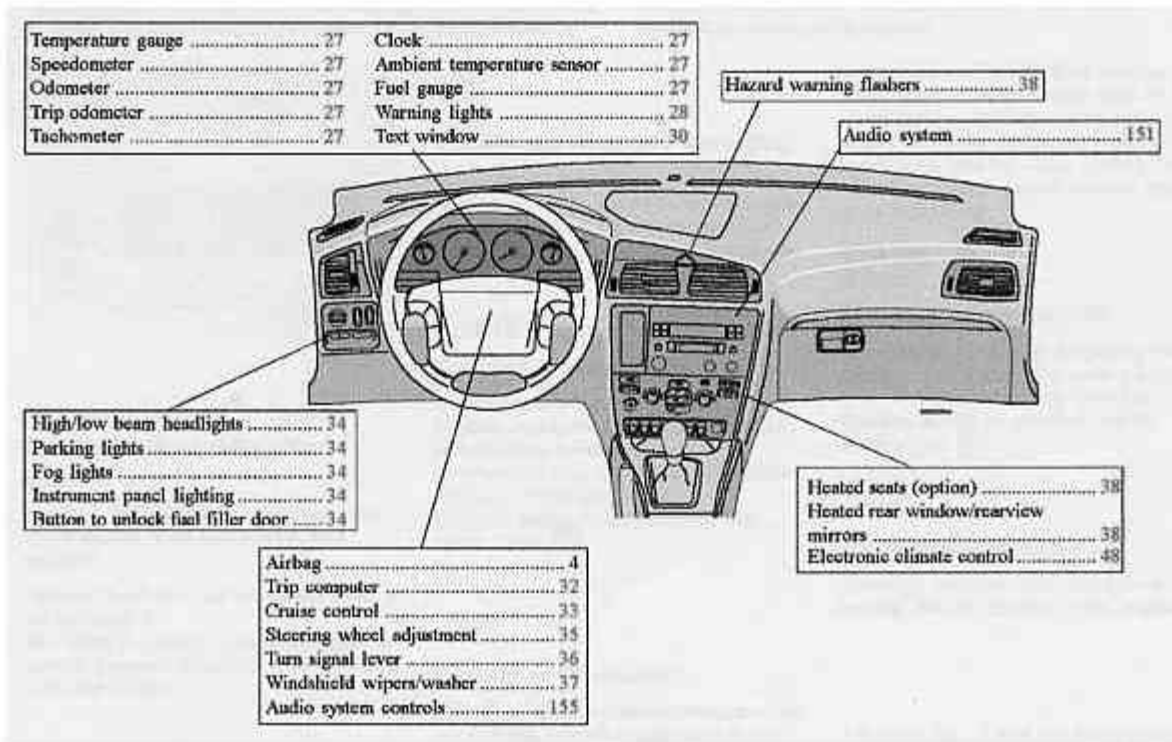

pg. 27 Instrument panel

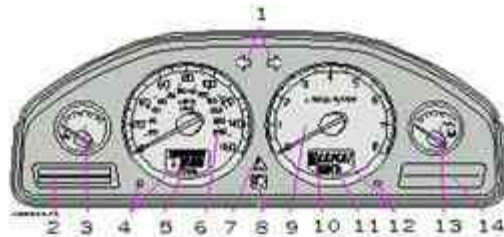

1 Turn signals

2 Text window

3 Temperature gauge

The pointer should be approximately midway on the gauge when driving.

Do not drive the car if the warning light is on. The text window will provide you with additional information.

If the engine temperature remains high, check coolant level - see [page 131](#).

4 Trip odometer/reset button

The trip odometer is used for measuring shorter distances. The last digit indicates 1/10 mile/kilometer. Press the button quickly to toggle between trip odometers 1 and 2. Hold in the button for more than 2 seconds to reset.

5 Odometer

6 Speedometer

7 General warning light (see [page 28](#)).

8 High beam indicator light

9 Tachometer

Indicates engine speed in thousands of rpm. Do not drive for long with the needle in the red section. The engine has an built-in function preventing too high an engine speed. When this function operates, you may discern some pulsation, which is normal.

10 Gear and driving mode indicator The currently selected driving mode is displayed here. If you use the Geartronic function on the automatic transmission, the currently selected gear will be displayed.

11 Ambient temperature indicator

This display indicates the air temperature outside your car. A "snowflake" symbol in the text window is displayed when the temperature is in the range of 23 - 36° F (-5 - +2° C).

Please note that this symbol does not indicate a fault with your car.

At low speeds or when the car is not moving, the temperature readings may be slightly higher than the actual ambient temperature.

12 Clock/reset button

Turn the button to adjust the clock.

13 Fuel gauge

The fuel tank holds approximately 18.5 US gals (70 liters) or 19 US gals (72 liters) on models equipped with All Wheel Drive.

When the warning light comes on there are approximately 1.8 US gal. (8 liters) of fuel remaining.

14 Indicator and warning lights

pg. 28 Indicator and warning lights

The indicator and warning lights described on pages 28 and 29 should never stay on when driving*

When the ignition key is turned, all of the warning lights in the lower right-hand side of the instrument panel should go on to test the function of the bulbs. If a light does not go off after the engine has started, the system indicated should be inspected.

NOTE: The parking brake reminder light will not go off until the parking brake has been fully released.

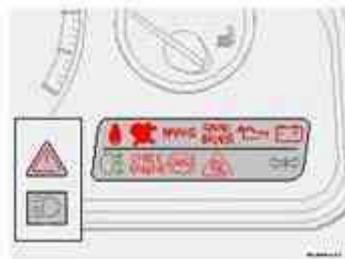

Warning lamp  in the center of the instrument panel

This lamp lights up **red** or **yellow** depending on the severity of the fault that has been detected.

Yellow light: Follow the instructions shown in the text window.

Red light: Stop the car as soon as possible in a suitable location and read the message shown in the text window.



Supplemental Restraint System (SRS)

If the light comes on (or stays on after the vehicle has started), the SRS diagnostic system has detected a fault. Drive to an authorized Volvo retailer for an inspection of the system. See the SRS section for more information.

BRAKE

Brake failure warning light

If the light comes on while driving or braking, stop immediately, open the hood and check the brake fluid level in the reservoir. See [page 134](#) for reservoir position and [page 137](#) for instructions.

Canadian models are equipped with this warning light: 



Oil pressure warning light

If the light comes on while driving, stop the car and then stop the engine immediately and check the engine oil level. See [page 135](#). If the light stays on after restart, have the car towed to the nearest authorized Volvo retailer. After hard driving, the light may come on occasionally when the engine is idling. This is normal, provided it goes off when the engine speed is increased.

Parking Brake

Parking brake reminder light

This light will be on when the parking brake (hand brake) is applied. The parking brake lever is situated between the front seats.

Canadian models are equipped with this warning light: 



Generator warning light

If the light comes on while the engine is running, have the charging system checked.

* Rear fog light, if used, and trailer turn signal, if towing a trailer, will go on while driving.



Rear fog light

This light indicates that the rear fog light is on.



Malfunction indicator lamp

On-Board Diagnostic II (OBDII): As you drive, a computer called "OBDII" monitors your car's engine, transmission, electrical and emission systems. The CHECK ENGINE light will light up if the computer senses a condition that potentially may need correcting. When this happens, please have your car checked by a Volvo retailer as soon as possible.

A CHECK ENGINE light may have many causes. Sometimes, you may not notice a change in your car's behavior. Even so, an uncorrected condition could hurt fuel economy, emission cleanliness, and driveability. Extended driving without correcting the cause could even damage other components in your car.

Canadian models are equipped with this warning light: 

NOTE: If the fuel filler cap is not closed tightly or if the engine is running when the car is refueled, the Malfunction Indicator Lamp may indicate a fault. However, your vehicle's performance will not be affected. Use only Volvo original or approved fuel filler caps.



Anti-lock Brake System ABS

If the warning light comes on, there is a malfunction of the ABS system (the standard braking system will still function). The vehicle should be driven to a Volvo retailer for inspection. See [page 19](#) for additional information.



Stability Traction Control (STC) system (option), or Dynamic Stability and Traction Control (DSTC) system (option)

An indicator light will flash when STC or DSTC is actively working to stabilize the car. See [pages 20-21](#) for more detailed information.



Turn signal indicator - trailer (certain models)

If you are towing a trailer, this light will flash simultaneously with the turn signals on the trailer. If the light does not flash when signaling, neither the trailer's turn signals nor the car's turn signals are functioning.



Seat belt reminder

This symbol lights up to indicate that the driver has not fastened his/her seat belt.

pg. 30 Text information window

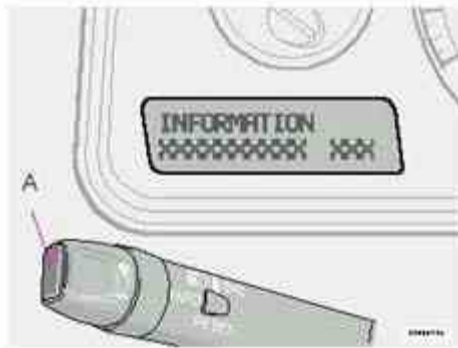

Messages in the text window

When a warning light in the instrument panel comes on, a message is also displayed in the text window. After you have read the message, you can erase it by pressing button A (see illustration above).

NOTE: Certain messages cannot be erased until the condition has been corrected.

Warning messages override text messages from any car feature that also uses the text window. A warning message must be acknowledged (erased) before you can access the feature of your choice. Press button A to erase the warning message.

Erased messages are stored in the system's memory until the required action has been taken. You can scroll through the stored messages by pressing button A. The text window can be cleared (the message will be returned to memory) by pressing button A again.

General messages

STOP SAFELY: Stop and switch off the engine - to help prevent serious risk of damage.

STOP ENGINE: Stop and switch off the engine - to help prevent serious risk of damage.

SERVICE URGENT: Take your car to an authorized Volvo retailer for inspection as soon as possible.

SEE MANUAL: Refer to your owner's manual. For additional information, please contact your Volvo retailer.

SERVICE REQUIRED: Take your car to an authorized Volvo retailer for inspection at your convenience (but preferably before the next scheduled maintenance service).

FIX NEXT SERVICE: Have the system affected inspected at the next scheduled maintenance service.

TIME FOR REGULAR SERVICE: This light will come on at 7,500 mile (12,000 km) intervals, after 750 hours of driving or after 12 months, whichever occurs first, to remind the driver that the service interval has been exceeded. The light will stay on for 2 minutes after start until reset by the servicing retailer.

pg. 31 Switches in the center console

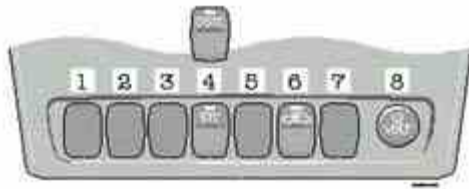

The positions of these buttons may vary, depending on the specifications of your car

1. Not in use

2. Not in use

3. Not in use

4. Stability Traction Control (STC)*/Dynamic Stability Traction Control (DSTC)******

Press this switch for at least half a second to turn the Spin Control (SC) function of the STC/DSTC system on or off. An LED in the switch will light up to indicate that the system is on. See [pages 20-21](#) for more information on STC/DSTC. The SC function should be switched off if you, for any reason, temporarily have to drive with tires of different dimensions (e.g., spare tire).

To help reduce the risk that the SC function is turned off inadvertently, the switch must be held in for at least half a second to disable this function. "STC/DSTC SPIN CONTROL OFF" will be displayed in the text window.

WARNING!

Please be aware that the car's handling characteristics may be affected if the Spin Control function is switched off.

5. Not in use

6. This button is used to temporarily disconnect alarm sensors. See [page 79](#) for further information.

7. Not in use

8. Auxiliary socket

This 12 volt socket can be used to plug in certain accessories such as cellular telephones, etc. The ignition key must be in position 1 (or higher) for the auxiliary socket to function.

NOTE: The auxiliary sockets can also be used for cigarette lighters, which are available at your Volvo retailer.

* Standard on all models except the T5 turbo.

** Standard on the T5 turbo, optional on all other models.

pg. 32 Trip computer (option)

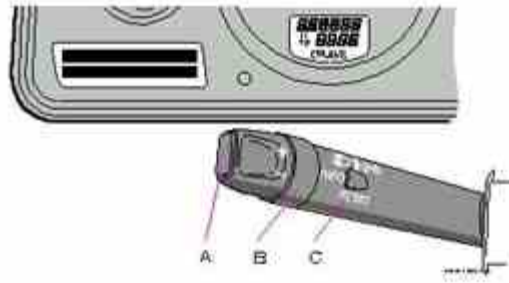

Trip computer

The trip computer stores information gathered from several systems in your car and has four menus that can be displayed in the text window.

- Driving distance on current fuel reserve
- Average fuel consumption
- Current fuel consumption
- Average speed
- Current speed in mph (Canadian models only)

NOTE: Warning messages from the car's monitoring systems will override the trip computer function. If a warning message is displayed in the text window while you are using the trip computer, you must acknowledge the message by pressing button A. Press button A again to return to the trip computer function.

Trip computer controls and functions

The four* trip computer functions can be accessed by twisting control B one step at a time in either direction. Twisting a fifth time** returns you to the original function.

The trip computer can be reset (current data will be erased from system memory) by pressing RESET (button C).

1. Driving distance on current fuel reserve

This function shows the approximate distance that can be driven on the fuel remaining in the tank. This calculation is based on average fuel consumption during the last 12 miles (20 km) of driving and the amount of fuel remaining in the tank when the reading was taken. When the driving distance on current fuel reserve is less than 12 miles (20 km), "----" will be displayed in the text window.

2. Average fuel consumption

This value indicates fuel consumption since the last time the trip computer was reset (by pressing RESET, button C). When the engine is switched off, information on fuel consumption is stored and remains in system memory until the RESET (button C) is pressed again.

3. Current fuel consumption

This value indicates the current fuel consumption, based on readings taken once per second. When the car is not moving, "----" will be displayed.

4. Average speed

This value indicates average speed since the last time the trip computer was reset (by pressing RESET, button C). When the engine is switched off, information on average speed is stored and remains in system memory until the RESET (button C) is pressed again.

5. Current speed in miles per hour (Canadian models only)

This function provides the driver with an instantaneous conversion of the car's current speed from km/h to mph.

*Five functions on Canadian models
**A sixth time on Canadian models



[Contents](#) | [Top of Page](#)

2003
VOLVO
V70

Chapter 3 - Climate control system

pg. 45 Climate control system

Ventilation 46

Climate control system - general information 47

Electronic Climate Control (ECC) 48

pg. 46 Ventilation

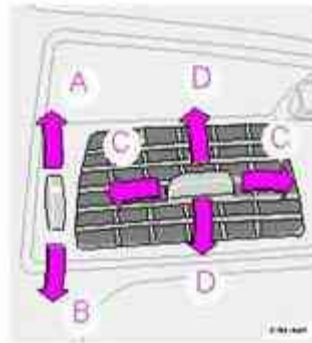

Air vents in dash

Air vents (dash)

A Open

B Closed

C Horizontal air flow

D Vertical air flow

Direct the outer air vents toward the side windows to demist.

In cold weather, close the air vents in the center of the dash to direct as much air as possible toward the windows.

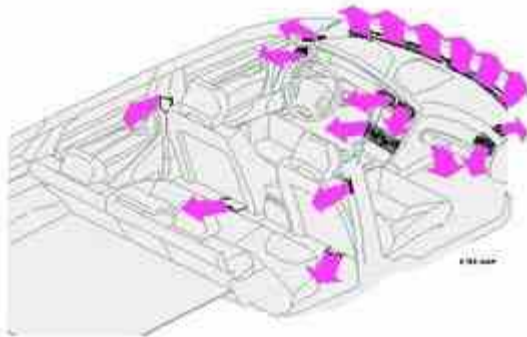

Air flow

The air that is drawn into the passenger compartment is distributed from 14 ventilation points.

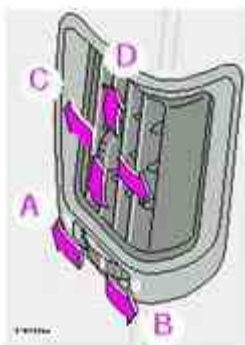

Air vents in door pillars

Air vents in door pillars

A Open

B Closed

C Horizontal air flow

D Vertical air flow

Direct the air vents toward the rear side windows to demist.

Direct the air vents toward the rear seat for the best heating/cooling effect.

pg. 47 Climate control system - general information

Condensation on the inside of the windows

Keeping the insides of the windows clean will help reduce the amount of condensation that forms on the windows. Use a commercial window cleaning agent to clean the windows.

Ice and snow

Always keep the air intake grille at the base of the windshield free of snow.

Cabin air filter

Replace the cabin air filter with a new one at the recommended intervals. The filter should be replaced more often when driving under dirty and dusty conditions. The filter cannot be cleaned and therefore should always be replaced with a new one.

Sensors

The sunlight sensor on the dashboard and passenger compartment temperature sensor in the ECC control panel should not be covered in any way as this could cause incorrect information to be sent to the ECC system.

Parking the car in warm weather

If your car has been parked in the sun in warm weather, opening the windows and sun roof (option) for several minutes before driving will help release the warm air from the passenger compartment. When the engine is running, close the windows and sun roof and use the recirculation function for several minutes to enable the air conditioning to cool the compartment as quickly as possible.

Windows and optional sun roof

The ECC system will function best if the windows and optional sun roof are closed. If you drive with the sun roof open, we recommend that you manually adjust the temperature and blower control (the LED in the AUTO switch should be off).

Acceleration

The air conditioning is momentarily disengaged during full-throttle acceleration.

ECC maintenance

All maintenance on the climate control systems should be carried out by an authorized Volvo service technician only.

Refrigerant

Volvo cares about the environment. The air conditioning system in your car contains a CFC-free refrigerant - R134a. This substance will not deplete the ozone layer. The system contains 2.2 lbs (1000 g) R134a and uses PAG oil.

Passenger compartment blower

Approximately 50 minutes after the ignition is turned off, the blower may come on automatically, and run for five minutes, to remove condensation in the A/C evaporator.

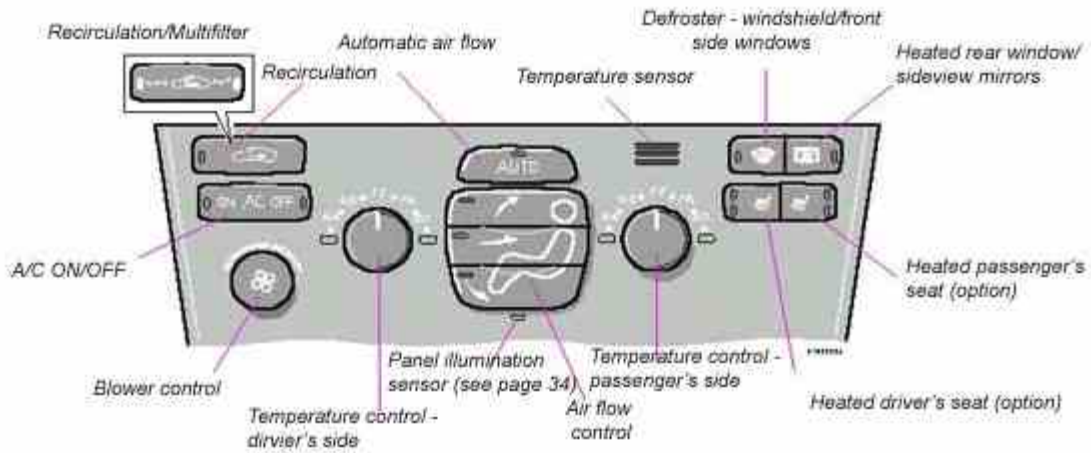

pg. 49 Electronic Climate Control (ECC)



AUTO

This function automatically regulates the Electronic Climate Control system so that the selected temperatures are maintained. The blower, heating, air distribution (air flow) and air conditioning are controlled. If you prefer to manually set any of these functions, the remaining functions will still be controlled automatically. Pressing the AUTO button overrides any settings that were previously made manually.



Temperature

These controls are used to individually set the temperature for both sides of the passenger compartment. Please note that the compartment will not be heated or cooled faster by setting the temperature higher or lower than necessary. Set the control to the temperature you prefer.

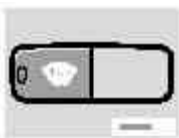

Defroster

This function demists/de-ices the windshield and front side windows. The LED in the switch will light up to indicate that the defrost function is engaged. Blower speed increases automatically and the air in the passenger compartment is dehumidified. Recirculation will not function while defrost is engaged.

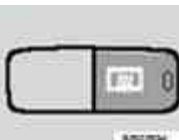

Heated rear window/sideview mirrors

This function demists/de-ices the rear window and sideview mirrors. The LED in the switch will light up to indicate

that the heating function is engaged. See [page 38](#) for additional information on this function.

CAUTION:

Never use ice scrapers made of metal as they can easily scratch the mirror surface.

pg. 50 Electronic Climate Control (ECC) - manual settings



Recirculation (see also [page 48](#))

Press this switch to engage the recirculation function (air in the passenger compartment recirculates - no fresh air enters the compartment). The LED in the switch will light up to indicate that the function is engaged.

- Use this function if the outside air is contaminated with exhaust gases, smoke, etc or to heat/cool the car quickly.
- Recirculation should not be used for more than 15 minutes. *If your windows begin to fog or mist, make sure that the recirculation function is switched off.*
- Selecting Defroster automatically switches recirculation off.
- **Timer mode activation:** (Cars with Interior Air Quality system have no timer mode) Press and hold the recirculation button for at least 3 seconds to activate a recirculation timer mode. The amber LED in the recirculation button will flash 5 times to show that the timer mode is being activated. In the time mode, each time the recirculation button is pressed, the climate control system will recirculate the air in the passenger compartment for 5 to 12 minutes, depending on the outside air and then revert back to fresh air.
- **Timer mode deactivation:** Press and hold the recirculation button for at least 3 seconds. The amber LED in the recirculation button will illuminate steadily for 5 seconds to show a return to "normal" mode.
- In normal mode, when the recirculation button is pressed, the climate control system will recirculate the air in the passenger compartment until the recirculation button is pressed again.
- **Timer mode memory:** If the car is turned off while timer mode is active, timer mode will still be active when the car is restarted.



Heated front seats (option)

Please see [page 38](#) for more information on this function.

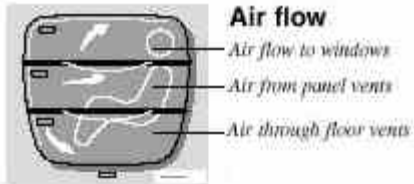

Press **AUTO** to automatically regulate air flow or press any combination of the controls shown in the illustration to manually adjust air flow. An LED in the switch will light up if an air flow control has been pressed.



Air conditioning ON/OFF

Press the switch to turn the air conditioning on or off. The "ON" or "OFF" LED will light up to indicate if the system

is switched on or off. Other functions will still be regulated automatically (if the **AUTO** switch is on).

- The air conditioning functions only at temperatures above 32° F (0° C).
- While the **Defroster** function is selected, the air conditioning is temporarily activated to dehumidify the air, even if you have manually switched the air conditioning off. This will only function if the blower is not switched off.



Blower control

Turn the control clockwise to increase or counterclockwise to decrease the blower speed. Pressing the AUTO switch will automatically regulate blower speed and override manual adjustment.

NOTE: Turning the blower control counterclockwise as far as possible (an orange LED next to the control will light up) will turn both the blower and the air conditioning off.

pg. 51 Electronic Climate Control (ECC) with Interior Air Quality system (option)

Interior Air Quality system (option)

Some cars are equipped with a Multifilter and Air quality sensor. The filter separates gases and particles, thereby reducing the amounts of odors and contaminants entering the car. The Air quality sensor detects increased levels of contaminants in the outside air. When the Air quality sensor detects contaminated outside air, the air intake closes and the air inside the passenger compartment is recirculated, i.e. no outside air enters the car. The filter also cleans

recirculated passenger compartment air. When the Air quality sensor is activated, the LED AUT comes on in



Operation:

Press  to activate the Air quality sensor (normal setting).

Or select one of three functions by pressing .

1. Press  : the LED AUT comes on. The Air quality sensor is now activated.

2. Press  : no LED is lighted. Recirculation not activated.

3. Press  : the LED MAN comes on. Recirculation is now activated.

You can switch between these three functions by repeatedly pressing



Keep the following in mind:

- Make it a rule to have the Air quality sensor activated at all times.
- Recirculation is limited in cold climates to avoid misting up.
- If misting occurs, you should deactivate the Air quality sensor.
- If the windows mist up, you can also use the windshield and side window defroster functions. See [page 49](#).
- The filter should be changed at the intervals listed in the Warranty and Service Records Information booklet. However, if the car is used in a severely contaminated environment, it may be necessary to change the filter more frequently.

pg. 52 Manual climate control with air conditioning, A/C



pg. 53 Manual climate control with air conditioning, A/C



A/C - ON/OFF

The air conditioning function is engaged by pressing ON and disengaged by pressing OFF. When you select Defroster , the air conditioning is automatically engaged if the fan is not set to position 0.



Heated front seats (option)

Please see [page 38](#) for more information on this function.



Heated rear window/sideview mirrors

This function demists/de-ices the rear window and sideview mirrors. The LED in the switch will light up to indicate that the heating function is engaged. See [page 38](#) for additional information on this function.

CAUTION:

Never use ice scrapers made of metal as they can easily scratch the mirror surface.





Recirculation

Recirculation can be used to shut out stale air, exhaust, etc. from the passenger compartment. The air in the passenger compartment is then recirculated, i. e. no air from outside the car is taken into the car when this function is activated. Recirculation (together with the air conditioning system) cools the passenger compartment more quickly in warm weather.

If you allow the air in the car to recirculate, there is a risk of icing and fogging, especially in winter. The timer function minimizes the risk of ice, misting and stale air.

Activate the timer function as follows:

- Press  for more than 3 seconds. The LED flashes for 5 seconds. The air recirculates in the car for 3-12 minutes depending on the outside temperature.

- The timer function is activated each time you press .

To switch off the timer function :

- Press  again for more than 3 seconds. The LED lights for 5 seconds to confirm your selection.

Recirculation is always disconnected when you select Defroster .



Blower

Blower speed can be increased or decreased by turning the knob. If the knob is set to 0, the air conditioning function is automatically disengaged.



Temperature





Turn the control to set the temperature for the driver's and passenger's sides of the car. For cooler air, the air conditioning function must be engaged.



Air distribution

Use the air distribution control positions (marked with dots) between the different symbols to fine-tune air distribution for the maximum comfort.

Air distribution

 <p>Air through front and rear air vents.</p>	<p>When you want good cooling in warm weather.</p>
 <p>Air to windows. Air is not recirculated in this position. Air conditioning is always connected. There is a certain amount of airflow to the air vents.</p>	<p>When you want to remove ice and fog from the windshield. Set the blower to its highest setting!</p>
 <p>Air to both floor and windows. There is a certain amount of airflow to the air vents.</p>	<p>When you want comfortable conditions and good demisting in cold weather!</p>
 <p>Air to floor. There is a certain amount of airflow to the air vents and the defroster vents for the windshield and side windows.</p>	<p>When you want to warm your feet.</p>
 <p>Air to floor and air vents.</p>	<p>In sunny weather with cool outside temperature.</p>



2003
VOLVO
V70

Chapter 4 - Interior

pg. 55 Interior

[Front seats \(electrically operated\)](#) 56

[Front seats \(manually operated\)](#) 58

[Storage compartments](#) 59

[Storage compartment, front](#) 60

[Rear seat and cargo area](#) 63

[Spare tire](#) 72

[Auxiliary seat in cargo area, Extra handgrip - XC70](#) 73

[Interior lighting](#) 74

pg. 56 Front seats



Electrically operated front seats (option)

From the time the driver's door is unlocked, the driver's seat can be adjusted with the ignition off during a **10 minute period, if the door remains opened**. If the door is closed, the seat can be adjusted for 40 seconds.

1 - Power seat control panel

2 - Lumbar support

Turn the control for softer or firmer lumbar support.

Move the seat as far rearward as possible for easiest access to the lumbar support control.

Electrically operated seats with memory function (option)*

Power seat control panel

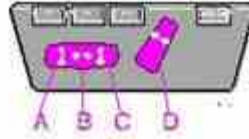

- A Front edge of seat (raise/lower)
- B Forward - rearward
- C Rear edge of seat (raise/lower)
- D Backrest tilt

WARNING!

- Because the driver's seat can be adjusted with the ignition off, children should never be left unattended in the car.
- Movement of the seat can be STOPPED at any time by pressing any button on the power seat control panel.
- Do not adjust the seat while driving. The seat should be adjusted so that the brake pedal can be depressed fully. In addition, position the seat as far rearward as comfort and control allow.
- The seat rails on the floor must not be obstructed in any way when the seat is in motion.

Programming the memory



Three seat positions can be programmed. To program a seat position:

- 1 Adjust the seat to the desired position.
- 2 Hold down the MEM button.
- 3 While holding down the MEM button, press button 1 to program the current position of the seat.

Buttons 2 and 3 can be programmed in the same way. To move the seat to a programmed position, press and hold down button 1, 2 or 3 until the seat moves to the preset position and stops.

As a safety precaution, the seat will stop automatically if the button is released before the seat has reached the programmed position.

NOTE: The seat has an overload protector which engages if an object blocks the movement of the seat. If this happens, remove the object and wait 20 seconds before operating the seat again.

* This option is only available on the driver's seat.

Electrically operated seats - general information

Adjusting the front seats:

The passenger's seat can only be adjusted if the ignition key is in position I or II.

Driver's seat: The driver's seat can be adjusted if the ignition key is in position I or II (see [page 35](#)). However, it can also be adjusted:

- Within 40 seconds after the ignition has been switched off (even if the key has been removed from the ignition switch).
- Within 40 seconds after the driver's door has been unlocked with the key or remote control and opened. The key does not have to be in the ignition switch during this period.

Remote keyless entry system and driver's seat

The remote control transmitter also controls the electrically operated driver's seat in the following way:

- Adjust the seat to your preferences.
- When you leave your car, lock it using the remote control.
- The next time you unlock the driver's door with the **same** remote control (the one you used to lock the doors with) and open the driver's door, the driver's seat will automatically move to the position in which you left it. The seat will move to this position even if someone else has adjusted it since you last unlocked the car with the same remote control.

NOTE:

- This feature will work in the same way with all of the remote control transmitters (up to 3) that you use with your car.
- This feature will not function if you lock your car with the key.

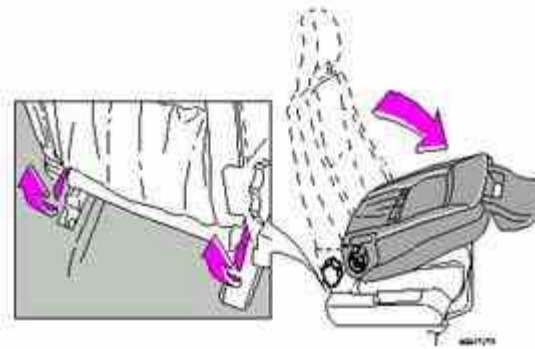

Folding front seat backrest

The passenger seat backrest can be folded down to the horizontal position for carrying long loads. To fold down the backrest:

- Move the seat as far rearward as possible
- Adjust the backrest tilt to the most upright position
- Lift the catches on the lower rear side of the backrest
- Without releasing the catches, push the backrest forward
- Move the seat as far forward as possible

WARNING!

Cover sharp edges on the load to help prevent injury to occupants. Secure the load to help prevent shifting during sudden stops.

pg. 58 Front seats

Manual height adjustment - front seat

The front edges of the driver and passenger seat cushions can be adjusted to seven different settings and the rear edges to nine different settings.

Lever (A) - adjusting the front edge of the seat.

Lever (B) - adjusting the rear edge of the seat.

Manual front-rear adjustment

The seat can be moved forward or rearward by pulling up on the front-rear adjustment bar.

Check that the seat is securely locked into position after adjusting.

WARNING!

Do not adjust the seat while driving. The seat should be adjusted so that the brake pedal can be depressed fully. In addition, position the seat as far rearward as comfort and control allow.



pg. 59 Storage compartments

Clip for toll booth tickets, etc.

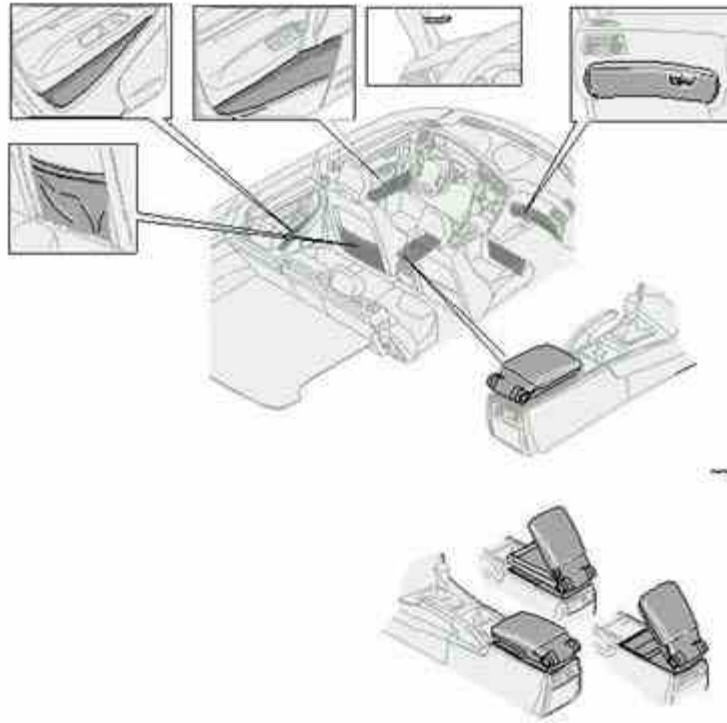

WARNING!

Make sure that no hard, sharp or heavy objects lie on or in any of the storage places where they might cause injury during heavy braking.

Ashtray (option)

To empty the ashtrays:

Front seat, open the ashtray, pull out the insert. Rear seat, as above.

Cup holders

Some models are equipped with cup holders for the front and rear seat occupants. You can also use the center console's storage compartment for cassette tapes, CD's etc.

Coin compartment (option)

To remove the coin compartment: Press the middle of the compartment while pulling it straight up.

Storage compartment and armrest

Inside the armrest there is a storage compartment which you may use for different personal accessories.

The armrest's lid is twofold.

To open only the upper lid: press the locking mechanism underneath the upper lid and fold the lid backwards to desired position.

To open the upper and lower lid: lift the lid from underneath upwards and fold to desired position.

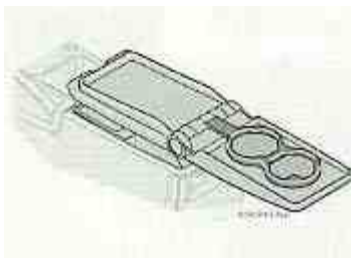

Cup holder in the center console for rear seat passengers (XC70 only)

This cup holder is only available on the XC70 with a 3-section rear seat.

- To use the cup holder, open the cover on the center console and fold it rearward. The cup holder and the cover open together.
- The cup holder and the cover can be closed separately.

NOTE: If the cup holder is subjected to weights above approximately 12 lbs (5 kg), it will fold down slightly to help prevent damage to the hinges.

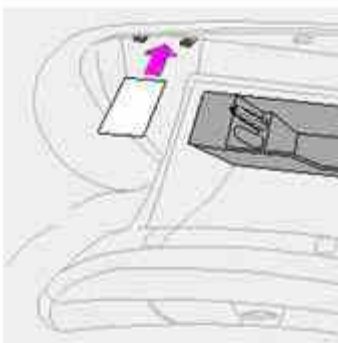

Storage in the glove compartment

The glove compartment has storage spaces designed specifically to hold credit cards, pens, and pencils.



Pen holder on the center console



Coat hanger

Use the coat hanger for clothes of normal weight.

pg. 62 Folding Table in rear seat



Folding Table (option)

Pull the tab and fold the table section forward.

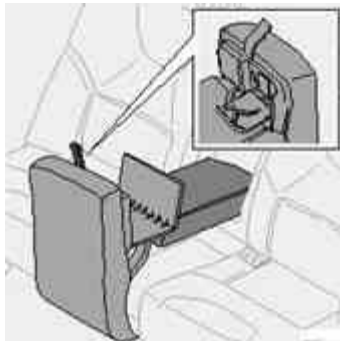

Fold the armrest in the backrest forward. Fold out the table so that it rests on the armrest. Press to release the cup holder. You do not have to fold the backrest forward, if you only want to use the cup holder.

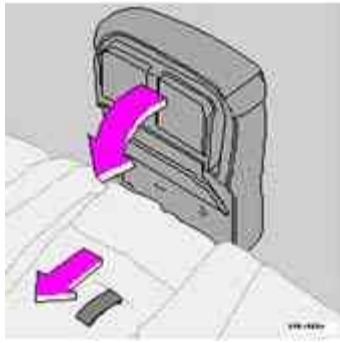

To close: Fold the table section upward into place. Fold the arm under the table inward being careful not to pinch your hand. Pull the handle and fold the table section back into place.



[Contents](#) | [Top of Page](#)

2003
VOLVO
V70

Chapter 5 - Keys, Locks, Alarm

pg.75 Keys, Locks, Alarm

[Keys, Exterior courtesy lights, Locking and unlocking the car](#) 76

[Remote keyless entry system](#) 77

[Unlocking the tailgate, Central locking buttons, "Trunk lock" function](#) 79

[Alarm](#) 80

[Child safety locks - rear doors](#) 82

pg. 76 Keys, Exterior courtesy lights, Locking and unlocking the car

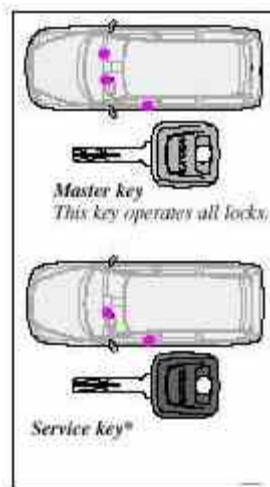

Keys

Two keys are provided with your car; a master key and a service key. The master key, the remote control, and the central locking button may all be used to lock and unlock all of your car's locks.

The service key will operate only the driver's door and the ignition switch. It is intended to help deter unwanted entry into the glove compartment and trunk.

Turn the key once to unlock the driver's door and the fuel filler door.

Turn the key again (within 10 seconds) to unlock all doors and the tailgate. One turn with the key towards lock in the drivers door locks all doors and tailgate.

Use the switch on the front door armrests to lock/unlock the car from the inside.

WARNING!

If the doors are locked while driving, this may hinder rapid access to the occupants of the car in the event of an accident. (Also see information on "Child safety locks").

NOTE: To help prevent accidentally locking the keys in the car, the central locking system is designed to unlock the doors immediately if the key is left in the ignition switch, the car is locked using the lock button on the door and the door is then closed. **A sound from the lock will be audible at this time.**

Please note that this function will not unlock the doors if the engine is running.

Immobilizer (start inhibitor)

Each of the keys supplied with your car contains a coded transmitter. The code in the key is transmitted to an antenna in the ignition switch where it is compared to the code stored in the start inhibitor module. The car will start only with a properly coded key. If you misplace a key, take the other keys to an authorized Volvo retailer for reprogramming as an anti-theft measure.

*This key operates only driver's door and ignition switch/steering wheel lock.

This device complies with part 15 of the FCC rules. Operation is subject to the following condition: (1) This device may not cause harmful interference, and (2) this device must accept any interference received, including interference that may cause undesired operation.

Exterior courtesy lights

Home Safe System

When you leave your car at night, you can make use of the courtesy lighting function:

- Remove the key from the ignition switch.
- Pull the direction indicator lever towards the steering wheel (as when activating the high beams).
- Exit the car and lock the doors.

The headlights, parking lights, license plate lights and the lights in the sideview mirrors will now come on and remain on for 30, 60 or 90 seconds (the time interval is at your discretion and can be changed by an authorized Volvo retailer).

Approach lighting

When approaching the car at night, press the yellow button in the central locking remote control (see illustration on [page 77](#)). This lights up the interior courtesy light, parking lights, license plate lights and the lights in the sideview mirrors.

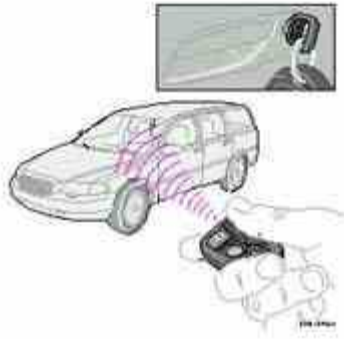

Remote keyless entry system

Your car is equipped with a remote control transmitter. This transmitter uses a radio frequency which will allow "keyless" entry into the passenger compartment or the tailgate. Your car is supplied with two coded key ring transmitters, which will enable you to lock/ unlock all doors and the tailgate from a distance of 10-15 feet (3-5 meters). The remote transmitter will also activate or deactivate the your car's alarm system(s). **The car can also be locked/unlocked with the key.**

If one of the transmitters is misplaced, contact your nearest authorized Volvo retailer for assistance.



Buttons in remote control

*1 - Lock, 2 - Unlock, 3 - Open tailgate
4 - "Panic" function *, 5 - Approach lighting*

Using the remote control

- Press the **LOCK** button once to lock all doors, fuel filler door and tailgate.
- Press the **UNLOCK** button **once** to unlock the driver's door only. Press this button again (within 10 seconds) to unlock all doors, fuel filler door and tailgate.
- To open the tailgate (without unlocking the other doors), press the tailgate-unlock button **twice**.

NOTE:

- If the doors are unlocked with the remote, the locks will automatically reengage (re-lock) and the alarm will reset after 2 minutes unless a door has been opened.
- The lock/unlock and alarm features can also be utilized by using the keys.

FCC ID:LQNP2T-APU

This device complies with part 15 of the FCC rules. Operation is subject to the following conditions: (1) This device may not cause harmful interference, and (2) this device must accept any interference received, including interference that may cause undesired operation.

Canadian 2306104388

Model 504 2927 by Donnelly Operation is subject to the following conditions: (1) this device may not cause interference, and (2) this device must accept any interference, including interference that may cause undesired operation of the device

Canadian 2306104388A

Model 509 977 by Connaught Electronics Operation is subject to the following conditions: (1) this device may not cause interference, and (2) this device must accept any interference, including interference that may cause undesired operation of the device

* See [page 80](#) for more information on this function.

pg. 78 Remote keyless entry system

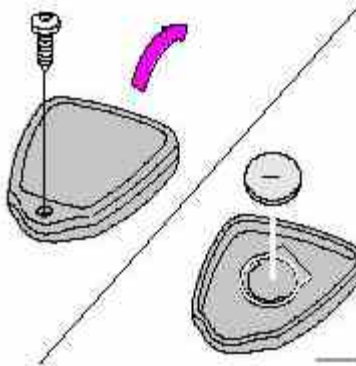

Remote keyless entry system - replacing batteries

If the range of the transmitter is noticeably reduced, this indicates that the battery is weak and should be replaced.

To replace the battery

- Remove the screw on the transmitter cover with a small screwdriver
- Remove the cover carefully pressing it rearward/upward
- Replace the battery with a new 3-volt, CR 2032 battery. The battery should be inserted with the minus side upward. Avoid touching the contact surfaces of the battery with your fingers.
- Reinstall the cover and tighten the screw to help protect the transmitter.

NOTE: The old battery should be disposed of properly at a recycling center or at your Volvo retailer.

WARNING!

Volvo does not recommend using the transmitter to lock the doors from inside the car. The alarm would be activated and would sound when one of the doors is opened. The doors must not be locked using the remote transmitter while the vehicle is occupied. In case of an accident, this may hinder rapid access to the occupants of the vehicle. The alarm will also sound.

pg. 79 Locking and unlocking the car

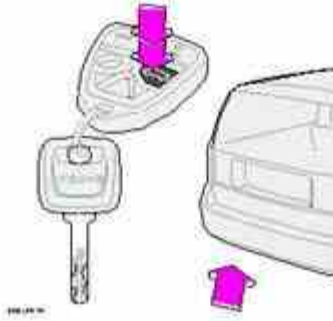

Unlocking the tailgate

The tailgate lock is incorporated in the central locking system and is locked or unlocked when the driver's door is locked/unlocked.

The tailgate can be unlocked by:

- Pressing UNLOCK on the remote control twice.
- Using the central locking button on the driver's door.
- Pressing twice on the remote control's tailgate unlock button.

Automatic relocking:

If you use the tailgate unlock button to unlock the tailgate without opening it, it will automatically relock after approximately 2 minutes.

However, if you open the tailgate and close it again, it will remain unlocked and the alarm will not be rearmed. Press the lock button on the remote control to relock the tailgate and rearm the alarm.



Central locking buttons

Central locking buttons

These buttons (located on the both front door armrests) can be used to lock/unlock all doors and the tailgate and set the alarm.

The rear passenger doors can also be locked and unlocked with the individual lock buttons on each door.

The alarm is automatically armed whenever you lock your car. When armed, the alarm continuously monitors a number of points on the car. The following conditions will set off the alarm:

- The hood is forced open.
- The tailgate is forced open.
- A door is forced open.
- The ignition switch is tampered with.
- If there is movement in the passenger compartment (if the car is equipped with the optional movement sensor).
- The car is lifted or towed (if the car is equipped with the optional inclination sensor).
- The battery is disconnected (while the alarm is armed).

Arming the alarm

Press the LOCK button on the remote control, lock the car using the key in the driver's door or press the central lock button on one of the front doors with the door open. One long flash of the turn signals will confirm that the alarm is armed.

Disarming the alarm

Press the UNLOCK button on the remote control or unlock the doors with the key.

Turning off (stopping) the alarm

If the alarm is sounding, it can be stopped by pressing the UNLOCK button on the remote control or by unlocking the driver's door with the key.

Visual alarm signal

The visual alarm signal is given by flashing all turn signals and turning on the interior lighting for approximately 5 minutes.

Audible alarm signal

An audible alarm signal is given by a battery powered siren. One alarm cycle lasts for 25 seconds.

"Panic" button

In an emergency situation, this feature can be used to attract attention. Activate the "panic" function by pressing the red button on the remote control (see illustration on [page 77](#)) for at least 3 seconds or by pressing this button twice within 3 seconds. The turn signals will flash, the interior lights will go on and the car's horn will sound.

The function can be turned off by pressing any of the buttons on the remote control or will stop automatically after 25 seconds. When a button is pressed, there is a 5 second delay before the panic alarm is deactivated.

NOTE: This function will **NOT** unlock the car.

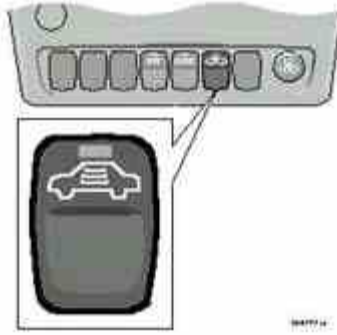

Temporarily turning off the alarm sensor(s) - accessory

This button will only be found in cars equipped with the optional inclination and/or movement sensors. In certain situations it may be desirable to turn off the optional inclination and movement alarm sensors if, for example, you drive your car onto a ferry where the rocking of the boat could trigger the alarm or if a pet is left in the car with the doors locked.

To temporarily turn off the inclination and movement alarm sensors from the alarm system:

From the time the ignition key is turned from the Drive position (position II) until you lock the car, you can press the button in the center console *. The LED in the switch will light up and a message will be displayed in the text window to indicate that the sensors are disconnected.

The car can then be locked in the usual way to set the alarm.

NOTE: The optional sensors are automatically reconnected to the alarm system the next time the car is unlocked and then locked again.

LED alarm status signals

The status of the alarm system is indicated by the red LED at the top of the dash:

- LED off - the alarm is not armed
- LED flashes once per second - the alarm is armed
- LED flashes rapidly before the ignition is switched on - the alarm has been triggered
- **Fault in the alarm system:** If a fault has been detected in the alarm system, a message will be displayed in the text window. Contact a Volvo retailer.

Automatic re-lock/re-arm system

If the car is unlocked with the remote, the car will re-lock and the alarm will re-arm after 2 minutes unless a door or the tailgate has been opened.

* The position of this button may vary, depending on the specifications of your car.

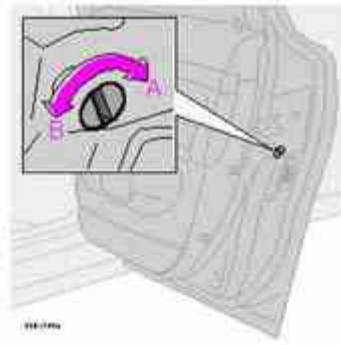
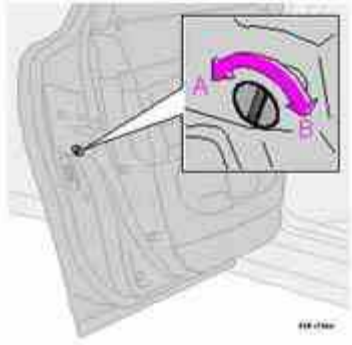

Child safety lock control in left rear door Child safety lock control in right rear door

Child safety locks - rear doors

The controls are located on the rear door jambs. Use a screwdriver to adjust these controls.

A The door cannot be opened from the inside. Normal operation from the outside.

B The door lock functions normally.

WARNING!

Remember, in the event of an accident, the rear seat passengers cannot open the doors from the inside with the buttons in position A.



[Contents](#) | [Top of Page](#)

2003
VOLVO
V70

Chapter 6 - Starting and driving

pg. 83 Starting and driving

Fuel requirements	84
Fuel Formulations	85
Refueling	86
Starting the engine	87
Manual transmission	89
Automatic transmission (AW5)	90
Automatic transmission (Geartronic)	92
All Wheel Drive	94
Driving economy	95
Points to remember	96
Roof racks/load carriers	97
Emergency towing	99
Vehicle towing information	100
Towing a trailer	101
Detachable trailer hitch	102
Jump starting	103
Winter driving	104
Long distance trips	105
Three-way catalytic converter	106

pg. 84 Fuel requirements

Fuel requirements

Octane rating: Volvo engines are designed for optimum performance on unleaded premium gasoline with an octane

rating AKI of 91, or above. AKI (ANTI KNOCK INDEX) is an average of the Research Octane Number, RON, and the Motor Octane Number, MON. $(RON + MON/2)$. The minimum octane requirement is AKI 87 (RON 91).

Deposit control gasoline (detergent additives)

Volvo recommends the use of gasoline containing deposit control additives. These additives have shown to be effective in keeping injectors and intake valves clean. Consistent use of deposit control gasolines will help ensure good driveability and fuel economy. If you are not sure whether the gasoline contains deposit control additives, check with the service station operator.

Unleaded fuel

Each Volvo has a three-way catalytic converter and must use only unleaded gasoline. U.S. and Canadian regulations require that pumps delivering unleaded gasoline be labelled "UNLEADED". Only these pumps have nozzles which fit your car's filler inlet. It is unlawful to dispense leaded fuel into a vehicle labelled "unleaded gasoline only". Leaded gasoline damages the three-way catalytic converter and the heated oxygen sensor system. Repeated use of leaded gasoline will lessen the effectiveness of the emission control system and could result in loss of emission warranty coverage. State and local vehicle inspection programs will make detection of misfueling easier, possibly resulting in emission test failure for misfueled vehicles.

NOTE: Some U.S. and Canadian gasolines contain an octane enhancing additive called methyl-cyclopentadienyl manganese tricarbonyl (MMT). If such fuels are used, your Emission Control System performance may be affected, and the Check Engine light (malfunction indicator lamp) located on your instrument panel may light. If this occurs, please return your vehicle to an authorized Volvo retailer for service.

Gasoline containing alcohol and ethers

"Oxygenated fuels"

Some fuel suppliers sell gasoline containing "oxygenates" which are usually alcohols or ethers. In some areas, state or local laws require that the service pump be marked indicating use of alcohols or ethers.

However, there are areas in which the pumps are unmarked. If you are not sure whether there is alcohol or ethers in the gasoline you buy, check with the service station operator. To meet seasonal air quality standards, some areas require the use of "oxygenated" fuel.

Volvo allows the use of the following "oxygenated fuels; however, the octane ratings listed on this page must still be met.

Alcohol - Ethanol: Fuels containing up to 10% ethanol by volume may be used. Ethanol may also be referred to as Ethyl alcohol, or "Gasohol".

Ethers - MTBE: Fuels containing up to 15% MTBE may be used.

CAUTION! Do not use gasolines containing methanol (methyl alcohol, wood alcohol). This practice can result in vehicle performance deterioration and can damage critical parts in the fuel system. Such damage may not be covered under the New Vehicle Limited Warranty.

pg. 85 Fuel requirements

Carbon Monoxide - Important Warning

Carbon monoxide is a poisonous, colorless, and odorless gas. It is present in all exhaust gases. If you ever smell exhaust fumes inside the vehicle, make sure the passenger compartment is ventilated, and immediately return the vehicle to your retailer for correction.

Fuel Formulations

Do not use gasoline that contains lead as a knock inhibitor, and do not use lead additives. Besides damaging the exhaust emission control systems on your car, lead has been strongly linked to certain forms of cancer. Many fuels contain benzene as a solvent. Unburned benzene has been strongly linked to certain forms of cancer. If you live in an area where you must fill your own gas tank, take precautions. These may include:

- standing upwind away from the filler nozzle while refueling
- refueling only at gas stations with vapor recovery systems that fully seal the mouth of the filler neck during refueling
- wear neoprene gloves while handling a fuel filler nozzle.

Use of Additives

With the exception of gas line antifreeze during winter months, do not add solvents, thickeners, or other store-bought additives to your car's fuel, cooling, or lubricating systems. Overuse may damage your engine, and some of these additives contain organically volatile chemicals. Do not needlessly expose yourself to these chemicals.

pg. 86 Refueling



Refueling

The fuel tank holds approximately 18.5 US gals (70 liters) or 19 US gals (72 liters) on models equipped with All Wheel Drive, with sufficient volume left over to accommodate possible expansion of the fuel in hot weather. Be aware that the "usable" tank capacity will be somewhat less than the specified maximum. When the fuel level is low, such factors as ambient temperature, the fuel's "Reid vapor pressure" characteristics, and terrain can affect the fuel pump's ability to supply the engine with an adequate supply of fuel. Therefore, it is advisable to refuel as soon as possible when the needle nears the red zone, or when the fuel warning light comes on.

Fuel filler door

Press the button on the light switch panel (see illustration on [page 34](#)) when the car is at a standstill to unlock the fuel filler door. Please note that the fuel filler door will remain unlocked until the car begins to move forward. An audible click will be heard when the fuel filler door relocks.

If you intend to leave your car while it is being refueled, this feature enables you to lock the door/tailgate while leaving the fuel filler door unlocked.

You can also keep the car locked if you remain inside it during refueling. The central locking button does not lock the fuel filler door.

Be sure the fuel filler door is not obstructed and is completely closed after refueling. **Open the fuel filler cap slowly during hot weather conditions.**

NOTE: During a transitional period, a small number of service stations may still have fuel nozzles that are not compatible with the fuel filler neck on cars equipped with the evaporative control system. Please refer to [page 130](#) for

additional information.

CAUTION:

- Do not refuel with the engine running *. Turn the ignition off or to position I. If the ignition is on, an incorrect reading could occur in the fuel gauge.
- After refueling, close the fuel filler cap by turning it clockwise until it clicks into place *.
- Allow for fuel expansion by not overfilling the tank. Overfilling could also cause damage to the emission control systems.
- Avoid spilling gasoline when refueling. In addition to causing damage to the environment, gasolines containing alcohol can cause damage to painted surfaces, which may not be covered under the New Vehicle Limited Warranty.
- Do not use gasolines containing methanol (methyl alcohol, wood alcohol). This practice can result in vehicle performance deterioration and can damage critical parts in the fuel system. Such damage may not be covered under the New Vehicle Limited Warranty.

** If the fuel filler cap is not closed tightly or if the engine is running when the car is refueled, the Check Engine light (malfunction indicator lamp) may indicate a fault. However, your vehicle's performance will not be affected. Use only Volvo original or approved fuel filler caps.*

pg. 87 Starting the engine

Starting the engine

1. Fasten the seat belt.

WARNING!

Before starting, check that the seat, steering wheel and mirrors adjusted properly. Make sure the brake pedal can be depressed completely. Adjust the seat if necessary. See [page 56](#).

2. Apply the parking brake, if not already set. The gear selector (**automatic transmission**) is locked in the (P)ark position (**SHIFT-LOCK**). **Manual transmission: the clutch must be fully depressed.**

3. **Without touching the accelerator pedal**, turn the ignition key* to the starting position. Allow the starter to operate for up to 10 seconds. Release the key as soon as the engine starts. If the engine fails to start, repeat this step.

For cold starts at altitudes above 6000 ft (1800 meters), depress the accelerator pedal halfway and turn the key to the starting position. Release the pedal slowly when the engine starts.

NOTE:

On certain models, when the car is started, idle speed may be noticeably higher than normal for a short period, depending on the temperature of the engine.

This has been done to help bring components in the emission control system to their normal operating temperature as quickly as possible, which enables them to function normally.

4. To release the gear selector from the (P)ark position, the engine must be running (or the ignition key must be in position II) and the brake pedal must be depressed.

5. Select the desired gear. The gear engages after a very slight delay which is especially noticeable when selecting R.

NOTE:

- Your car is equipped with a **KEYLOCK** system. When the engine is switched off, the gear selector must be in the (P)ark position before the key can be removed from the ignition switch.

- When starting in cold weather, the transmission may shift up at slightly higher engine speeds than normal until the automatic transmission fluid reaches normal operating temperature.

* Your car is equipped with an electronic start inhibitor (immobilizer). The keys you received with your car are specially coded. The code in the key is transmitted to an antenna in the ignition switch where it is compared to the code stored in the start inhibitor module. The car can only be started if a properly coded key is used.

If two of the keys to your car are close together, e.g., on the same key ring, when you try to start the car, this could cause interference in the immobilizer system and result in the car not starting. If this should occur, remove one of the keys from the key ring before trying to start the car again.

pg. 88 Starting the engine

CAUTION:

- The engine should be idling when you move the gear selector. Never accelerate until after you feel the transmission engage! Accelerating immediately after selecting a gear will cause harsh engagement and premature transmission wear.
- Selecting P or N when idling at a standstill for prolonged periods time will help prevent overheating of the automatic transmission fluid.
- Do not race a cold engine immediately after starting. Oil flow may not reach some lubrication points fast enough to prevent engine damage.

WARNING!

- Always place the gear selector in Park and apply the parking brake before leaving the vehicle. Never leave the car unattended with the engine running.
- Always open garage doors fully before starting the engine inside a garage to ensure adequate ventilation. The exhaust gases contain carbon monoxide, which is invisible and odorless but very poisonous.
- An extra mat on the driver's floor can cause the accelerator pedal and the clutch to catch. Check that the movement of the accelerator pedal and clutch is not impeded. Not more than one protective floor covering may be used at one time.

pg. 89 Manual transmission



Shift positions

Depress the clutch pedal completely when changing gears*.

Remove your foot from the clutch pedal while driving. The shift pattern should be followed. Overdrive (5th gear) should be used as often as possible to help improve fuel economy. This gear should be engaged at speeds above approx. 50 mph (80 km/h).



Engaging reverse gear

Reverse gear should only be engaged from a complete stop.

CAUTION: Be careful that you do not inadvertently engage reverse while moving forward.

* Clutch interlock

The clutch must be fully depressed before you can start your car. If the clutch is not depressed, it will not be possible to start the engine.

WARNING!

An extra mat on the driver's floor can cause the accelerator pedal and the clutch to catch. Check that the movement of the accelerator pedal and clutch is not impeded. Not more than one protective floor covering may be used at one time.

pg. 90 Automatic transmission AW5

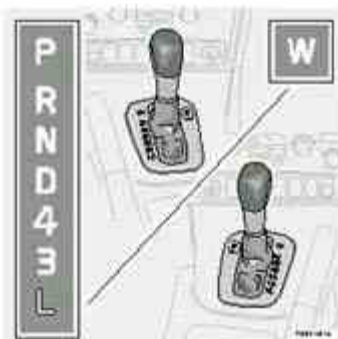

P (Park)

Use this position when starting the engine or parking the car.

Never use P while the car is in motion.

The parking brake should be set whenever the car is parked.

The gear selector is mechanically locked in the P position (SHIFTLOCK). To release the gear selector from this position, the engine must be running (or the ignition key must be in position II) and the brake pedal must be depressed.

WARNING!

Never leave the car unattended when the engine is running. If, by mistake, the gear selector is moved from P, the car may start moving.

R (Reverse)

Never engage R while the car is moving forward.

N (Neutral)

Neutral - no gear engaged. Use the parking brake.

D (Drive)

D is the normal driving position and should be used as often as possible to help improve fuel economy. The car should not be moving when shifting from R to the D position.

4 (Intermediate gear)

The transmission will shift automatically between gears 4, 3, 2 or 1 from this position. **The transmission cannot shift up to (D)rive from fourth gear.**

3 (Intermediate gear)

The transmission will shift automatically between gears 3, 2 and 1 from this position. The transmission cannot shift up to fourth gear or (D)rive from third gear.

L (Low gears)

The transmission is locked in gears 1 and 2 when the selector is in this position.

NOTE:

- Gears 4, 3, or L can be used if you are driving in a mountainous area, towing a trailer or to increase engine braking effect.
- The transmission has a built-in limiter designed to help prevent excessive engine speeds (high rpm) when gears 4, 3 or L are selected.

Automatic transmission -adaptive system

The automatic transmission is controlled by an adaptive control system that constantly monitors the way in which the transmission functions. It senses and adapts each gear shift for optimal performance. The system also monitors your particular driving style and adapts gear shifting accordingly.

pg. 91 Automatic transmission AW5

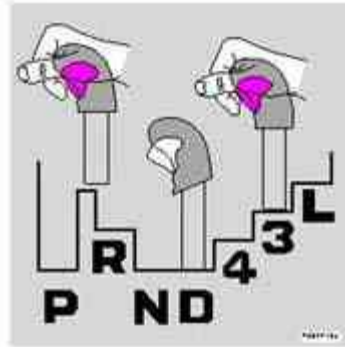

Automatic transmission - shift gate positions

The gear selector can be moved freely between N and D.

Depressing the button on the front of the gear selector knob enables you to move the gear selector to positions P, R, N, D, 4, 3 and L.



W Winter/Wet driving mode - enhanced vehicle traction

- Mode W will only function if the gear selector is in the (D)rive position.
- Press the button at the base of the gear selector to engage/disengage this driving mode (see illustration).
- An LED in the button will light up to indicate that W is engaged and this will also be displayed in the instrument panel (see [page 27](#)).
- This mode may be selected for starting/moving off on slippery roads.

Kickdown

Automatic shift to a lower gear (kickdown) is achieved by depressing the accelerator pedal fully and briskly. An

upshift will occur when approaching the top speed for a particular gear or by releasing the accelerator pedal slightly. Kickdown can be used for maximum acceleration or when passing at highway speeds.

Cold starts

When driving before the engine has reached its normal operating temperature, the transmission will shift up at slightly higher engine speeds to heat the three-way catalytic converter as quickly as possible.

pg. 92 Automatic transmission (Geartronic)



P (Park)

Use this position when starting the engine or parking the car.

Never use P while the car is in motion. The parking brake should be set whenever the car is parked.

The gear selector is mechanically locked in the P position (SHIFTLOCK). To release the gear selector from this position, the engine must be running (or the ignition key must be in position II) and the brake pedal must be depressed.

WARNING!

Never leave the car unattended when the engine is running. If, by mistake, the gear selector is moved from P, the car may start moving.

R (Reverse)

Never engage R while the car is moving forward.

N (Neutral)

Neutral - no gear engaged. Use the parking brake.

D (Drive)

D is the normal driving position and should be used as often as possible to help improve fuel economy. The car should not be moving when shifting from R to the D position.

Kickdown

Automatic shift to a lower gear (kickdown) is achieved by depressing the accelerator pedal fully and briskly. An upshift will occur when approaching the top speed for a particular gear or by releasing the accelerator pedal slightly. Kickdown can be used for maximum acceleration or when passing at highway speeds. **Kickdown does not function when the transmission is in the manual shift (geartronic) mode (see next page).**

Automatic transmission - adaptive system

The automatic transmission is controlled by an adaptive control system that constantly monitors the way in which the transmission functions. It senses and adapts each gear shift for optimal performance. The system also monitors your particular driving style and adapts gear shifting accordingly.

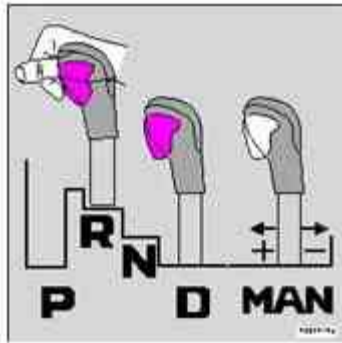

Automatic transmission - shift gate positions

You can move the gear selector freely between the (MAN)ual and (D)rive positions while driving.

Depress the button on the front of the gear selector knob to move between the R, N, D, and P positions.

Please see the following page for information on using the Geartronic manual shift mode.

pg. 93 Automatic transmission (Geartronic)

Manual shifting - Geartronic

You can move the gear selector freely between the (MAN)ual and (D)rive positions while driving. Gears 2, 3, and 4 have a "lock-up" function which reduces engine speed and helps save fuel. The currently selected gear will be displayed in the instrument panel (see [page 27](#)).

- To access the (MAN)ual shifting position from (D)rive, pull the gear selector back slightly from D and move it to the left to MAN.
- To return to the (D)rive position from MAN, move the gear selector to the right and push it forward to the (D)rive position.

While driving

If you select the (MAN)ual position while driving, the gear that was being used in the (D)rive position will also initially be selected in (MAN)ual position.

- Move the gear selector forward (toward "+") to shift to a higher gear or rearward (toward "-") to shift to a lower gear.

If you hold the gear selector toward "-", the transmission will downshift, one gear at a time, and will utilize the braking power of the engine. If the current speed is too high for using a lower gear, the downshift will not occur until the speed has decreased enough to allow the lower gear to be used.

- If you slow down to a very low speed, the transmission will automatically shift down.
- When starting in the (MAN)ual position, 3rd gear is the highest gear that may be selected.

NOTE: Kickdown (see previous page) **does not function** when the transmission is in the manual shift (geartronic) mode. The gear selector must be in the D (Drive) position.



W Winter/Wet driving mode - enhanced vehicle traction

- Mode W will function only if the gear selector is in the (D)rive position.
- Press the button at the base of the gear selector to engage/disengage this driving mode (see illustration).
- An LED in the button will light up to indicate that **W** is engaged and this will also be displayed in the instrument panel (see [page 27](#)).
- This mode may be selected for starting/moving off on slippery roads.

pg. 94 All Wheel Drive - option

All Wheel Drive (AWD) - general information

Your Volvo can be equipped with permanent All Wheel Drive, which means that power is distributed automatically between the front and rear wheels. Under normal driving conditions, most of the engine's power is directed to the front wheels. However, if there is any tendency for the front wheels to spin, an electronically controlled coupling distributes power to the wheels that have the best traction.

Tire dimensions

Volvo recommends that you always drive on tires of the same brand, size, construction (radial), tread pattern, load-, speed-, traction-, temperature-, and treadwear rating. Never drive on mixed tires, except for brief periods when the temporary spare tire is in use.

Always use properly inflated tires of correct dimensions. Tire size and inflation pressures are shown on the tire pressure label located inside the fuel filler door.

Tire Rotation

Volvo recommends rotating the tires every 7,500 miles (12,000 km). Tires should be rotated front-to-back/back-to-front only. Tires must maintain the same direction of rotation throughout their lifetime, and should never be rotated from one side of the vehicle to the other.

Temporary Spare

The temporary spare tire is for temporary, low-speed, short-distance use only. Replace it with a full-sized tire as soon as possible, in accordance with "Tire Rotation" above. Do not drive on the temporary spare at speeds above 50 m.p.h. (80km/h) or for distances greater than 50 miles (80 km).

Never install snow chains on a temporary spare.

pg. 95 Driving economy

Economical driving conserves natural resources

Better driving economy may be obtained by thinking ahead, avoiding rapid starts and stops and adjusting the speed of your vehicle to immediate traffic conditions. Observe the following rules:

- Bring the engine to normal operating temperature as soon as possible by driving with a light foot on the accelerator pedal for the first few minutes of operation. A cold engine uses more fuel and is subject to increased wear.
- Whenever possible, avoid using the car for driving short distances. This does not allow the engine to reach normal operating temperature.
- Drive carefully and avoid rapid acceleration and hard braking.
- Do not exceed posted speed limits.
- Avoid carrying unnecessary items (extra load) in the car.
- Maintain correct tire pressure. Check tire pressure regularly (when tires are cold).
- Remove snow tires when threat of snow or ice has ended.
- Note that roof racks, ski racks, etc., increase air resistance and also fuel consumption.
- Avoid using automatic transmission kickdown feature unless necessary.
- Avoid using the air conditioning when it is not required. When engaged, the conditioner's compressor places an additional load on the engine. However, at higher driving speeds, fuel consumption will be lower with the air conditioning on and the windows closed than with the air conditioning off and the windows open.
- Using the onboard trip computer's fuel consumption modes can help you learn how to drive more economically.

Other factors that decrease gas mileage are:

- Dirty air cleaner
- Dirty engine oil and clogged oil filter
- Dragging brakes
- Incorrect front end alignment Some of the above mentioned items and others are checked at the standard Maintenance Service intervals.

NOTE: Vehicles equipped with automatic transmissions should use (D)rive as often as possible and avoid using "kick-down" to help improve fuel economy. Vehicles equipped with manual transmissions should use fifth gear at highway speeds. At other times, choose the highest gear that still allows smooth acceleration.

Weight distribution affects handling

At the specified curb weight your car has a tendency to understeer, which means that the steering wheel has to be turned more than might seem appropriate for the curvature of a bend. This ensures good stability and reduces the risk of rear wheel skid. Remember that these properties can alter with the vehicle load. The heavier the load on the rear of the vehicle (e.g., heavily loaded (max. 220 lbs, 100 kg) cargo area or when towing a trailer, the less the tendency to understeer.

Handling, roadholding

Vehicle load, tire design and inflation pressure all affect vehicle handling. Therefore, check that the tires are inflated to the recommended pressure according to the vehicle load. See "Tire pressure" section. Loads should be distributed so that capacity weight or maximum permissible axle loads are not exceeded.

pg. 96 Points to remember

Cooling system

The risk for engine overheating is greatest, especially in hot weather, when:

- Towing a trailer up steep inclines for prolonged periods at wide open throttle and low engine rpm.
- Stopping the engine suddenly after high speed driving (so-called "after-boiling" can occur).
- To avoid overheating, the following rules should be followed: Do not drive for prolonged periods at engine speeds above 4500 rpm if you are towing a trailer in hilly terrain.

Reduce speed when towing a trailer up long, steep inclines. The risk of overheating can be reduced by switching off the air conditioning system for a short time.

Do not let the engine idle unnecessarily for prolonged periods.

Do not mount auxiliary lamps in front of the grill.

When the risk of overheating is imminent, or in the event of overheating (the temperature gauge goes repeatedly into, or stays continually in, the red section), the following precautions should be taken:

- Switch off the air conditioning system.
- Pull off the road, away from traffic, stop the car and put the gear selector into neutral.
- Switch the heater to full (maximum) position. Increase the engine speed to approx. 2000 rpm (twice idling speed) until the temperature begins to drop.

WARNING!

Do not remove coolant expansion tank cap. The coolant will be extremely hot.

If necessary, see [page 129](#) and [132](#) for information on checking and topping-up the coolant level.

CAUTION: Drive slowly and carefully if going through standing water (i.e. flooded roadways, etc.). Damage to the engine could result if excess water is drawn in through the air intake system. Never drive the vehicle in water deeper than 1 foot (300 mm). See the flood warning on [page 7](#).

WARNING!

- **Driving with the tailgate open:** Driving with the tailgate open could mean that poisonous exhaust gases enter the passenger compartment.

If the tailgate must be kept open for any reason, proceed as follows:

- Close the windows.
- Set the ventilation system control to air flow to floor, windshield and side windows and blower control to its highest setting.

- **Floor mats:** An extra mat on the driver's floor can cause the accelerator pedal to catch. Check that the movement of the accelerator pedal is not impeded. Not more than one protective floor covering may be used at one time.

Electrical system

When replacing the battery or when carrying out work involving the electrical system, the following should be observed:

- A battery connection to the wrong terminal will damage the electrical system. Be sure to connect the positive battery cable to the positive battery terminal and the negative battery cable to the negative battery terminal.
- If booster batteries are used for starting, they must be properly connected to minimize the risk of the electrical system being damaged. For correct connection, see "Jump starting" section.
- Never disconnect the battery circuit (for example, to replace the battery) while the engine is running, as this may damage the generator. Always make sure that all the battery connections are properly cleaned and tightened.
- If any electrical welding work is performed on the vehicle, the battery's ground lead (negative cable) and all the connecting cables of the generator must be disconnected and the welder cables placed as near the welding points as possible.
- The radio must be turned off before the battery is disconnected.
- Switch off the ignition for at least 10 minutes before disconnecting the battery.

pg. 97 Roof racks/Load carriers

Load carriers (accessory)

Load carriers are available as Volvo accessories. Observe the following points when in use:

- To avoid damaging your car and to achieve maximum safety when driving, we recommend using the load carriers that Volvo has developed especially for your car.
- Volvo-approved removable roof racks are designed to carry the maximum allowable roof load for this vehicle: 220 lbs (100 kg). For Non-Volvo roof racks, check the manufacturer's weight limits for the rack.
- Never exceed the rack manufacturer's weight limits and never exceed the maximum rated roof load of 220 lbs (100 kg).
- Avoid single-point loads. Distribute loads evenly.
- Place heavier cargo at the bottom of the load.
- Anchor the cargo correctly with appropriate tie-down equipment.
- **Check periodically that the load carriers and load are properly secured.**
- Remember that the car's center of gravity and handling change when you carry a load on the roof.
- The car's wind resistance (and correspondingly, fuel consumption) will increase with the size of the load.
- Drive smoothly. Avoid rapid starts, fast cornering and hard braking.



Load carrier attachment points

Attaching load carriers (models without rails)

The attachment brackets for the load carriers are located under the roof molding.

- 1 Make sure that the load carriers are placed in the right direction. See the mark on the decal under the cover.
- 2 Press the guide lugs into the holes (1).
- 3 Carefully lower the opposite side of the load carrier to the roof.
- 4 Loosen the tightening wheel slightly. Slide the hook on the load carrier attachment into the attachment bracket under the roof molding.
- 5 Turn the tightening wheel to secure the load carrier in the attachment bracket.
- 6 Repeat this procedure for the other load carrier attachments.
- 7 Check that the hooks on all four load carrier attachments are securely tightened in the respective attachment brackets on the roof of the car.
- 8 Press down the covers.

Check periodically that the load carriers and load are properly secured.

Reducing wind noise and improving fuel economy

To maximize fuel efficiency and minimize wind noise, Volvo recommends that load carriers be removed when not in use.

pg. 98 Load carriers (models with rails)



Position of load carriers

Make sure that the wing-shaped load carriers are installed on the roof rails with the rounded edge forward (see the inset illustration above). The load carriers are identical and can be placed anywhere along the roof rails.

Reducing wind noise and improving fuel economy

To maximize fuel efficiency and minimize wind noise, Volvo recommends that load carriers be removed when not in use.

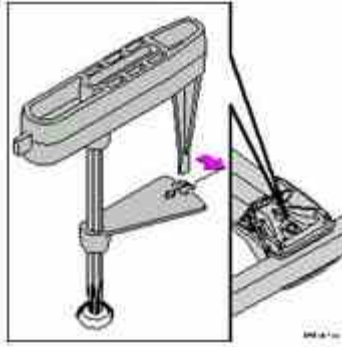

Fitting the load carriers (accessory)

Make sure that the load carrier is pressed firmly out against the roof rail. Screw the load carrier in place. Use the supplied torque wrench and tighten to the mark on the wrench (corresponding to 6 Nm). See illustration.

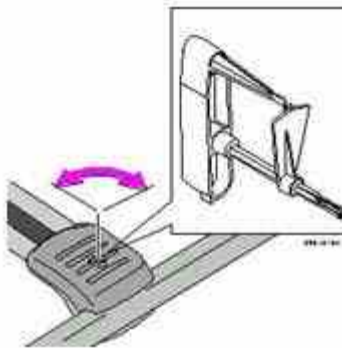

Load carrier cover

The car's ignition key or the stud on the edge of the supplied torque wrench can be used to undo or tighten the cover. Turn a quarter turn (90 degrees). See illustration.



[Contents](#) | [Top of Page](#)

2003 VOLVO V70

Chapter 7 - Wheels and tires

pg.107 Wheels and tires

[General information, Wear indicator, Tire economy, Flat spots](#) 108

[Snow chains, Snow tires/studded tires](#) 109

[Inflation pressure, Vehicle loading, Spare tire](#) 110

[Uniform tire quality grading](#) 111

[Changing wheels](#) 112

pg. 108 Wheels and tires

General information

Your vehicle is equipped with tires according to the tire information label on the inside of the fuel filler door.

The following is an **example** of a tire designation code: 225/55 R16

225 = tire width in mm.

55 = tire profile. This is the relationship (in percent) between the section height and width of the tire.

R = radial tires.

16 = diameter in inches.

The tires have good road holding characteristics and offer good handling on dry and wet surfaces. It should be noted however that the tires have been developed to give these features on snow/ice-free surfaces. **Certain models are equipped with "all-season" tires, which provide a somewhat higher degree of road holding on slippery surfaces than tires without the "all-season" rating.** However, for optimum road holding on icy or snow covered roads - **we recommend suitable winter tires on all four wheels.** When replacing tires, be sure that the new tires are the same dimensions, type (radial) and preferably from the same manufacturer, on all four wheels. Do not use bias ply tires. Otherwise there is a risk of altering the car's roadholding and handling characteristics.

NOTE: When storing wheel/tire assemblies (e.g. snow tires and wheels), either stand the assemblies upright, or suspend them off the ground. Laying wheel/tire assemblies on their sides for prolonged periods can cause wheel and/or tire damage.

Wear indicator

The tires have wear indicator strips running across or parallel to the tread. When approx. 1/16" (1.6 mm) is left on the tread, these strips become visible and indicate that the tire should be replaced.

Tires with less than 1/16" (1.6 mm) tread have very poor grip in rain or snow.

To improve tire economy:

- Maintain correct tire pressure. See the tire pressure label on the inside of the fuel filler door.
- Drive smoothly: avoid fast starts, hard braking and tire screeching.
- Tire wear increases with speed.
- Correct front wheel alignment is very important.
- Unbalanced wheels impair tire economy and driving comfort.
- Volvo does not recommend rotating the tires. However, if tires are rotated, they must be kept on the same side of the car so that they revolve in the same direction as before rotation.
- Hitting curbs or potholes can damage the tires and/or wheels permanently.

Flat spots

All tires become warm during use. After cooling, when the vehicle is parked, the tires have a tendency to distort slightly, forming flat spots. These flat spots can cause vibrations similar to the vibrations caused by unbalanced wheels. They do, however, disappear when the tire warms up. The degree to which flat spots form depends on the type of cord used in the tire. Remember that, in cold weather, it takes longer for the tire to warm up and consequently longer for the flat spot to disappear.

CAUTION: The car must not be driven with wheels of different dimensions/specifications or with a spare tire other than the one that came with the car. The use of different size wheels can seriously damage your car's transmission or driveline.

pg. 109 Wheels and tires

Snow chains

Snow chains can be used on your Volvo with the following restrictions:

- Snow chains should be installed on front wheels only. Use only Volvo approved snow chains.
- Special snow chains must be mounted on 215/55 R16. Consult your Volvo retailer.
- If accessory, aftermarket or "custom" tires and wheels are installed and are of a size different than the original tires and wheels, chains in some cases CANNOT be used. Sufficient clearances between chains and brakes, suspension and body components must be maintained. Snow chains cannot be used on 17" wheels.
- Some strap-on type chains will interfere with brake components and therefore CANNOT be used.
- **All Wheel Drive models:** Snow chains should only be installed on the *front* wheels. Only chains adapted for AWD models should be used.

Consult your Volvo retailer for additional snow chain information.

CAUTION:

- Check local regulations regarding the use of snow chains before installing.
- Always follow the chain manufacturer's installation instructions carefully. Install chains as tightly as possible and retighten periodically.
- Never exceed the chain manufacturer's specified maximum speed limit. In no case should you exceed 31 mph (50 km/h).
- Avoid bumps, holes or sharp turns when driving with snow chains.
- Vehicle handling can be adversely affected when driving with chains. Avoid fast maneuvering and hard braking.

Never allow the wheels to lock up during braking.

Snow tires, studded tires *

Tires for winter use:

Owners who live in or regularly travel through areas with sustained periods of snow or icy driving conditions are strongly advised to fit suitable winter tires to help retain the highest degree of traction. It is important to install winter tires **on all four wheels** to help retain traction during cornering, braking, and accelerating. Failure to do so could reduce traction to an unsafe level or adversely affect handling. Volvo does not recommend tire rotation. However, as with any other radial tires, if rotated, the tires must be kept on the same side of the car so that they revolve in the same direction as before rotation.

Volvo recommends 195/65 R15 snow tires on non-turbo models. Turbo models should be equipped with 205/55 R16 snow tires on all four wheels (215/65 R16 tires should be used on the XC70).

Winter tires wear more quickly on dry roads in warm weather. They should be removed when the winter driving season has ended.

Studded tires should be run-in 300-600 miles (500-1000 km) during which the car should be driven as smoothly as possible to give the studs the opportunity to seat properly in the tires. The tires should have the same rotational direction throughout their entire lifetime. In other words, if you wish to rotate the wheels, make sure that the same wheels are always on the same side of the car.

NOTE: Please consult state or provincial regulations restricting the use of studded winter tires before installing such tires.

* Where permitted.

pg. 110 Wheels and tires

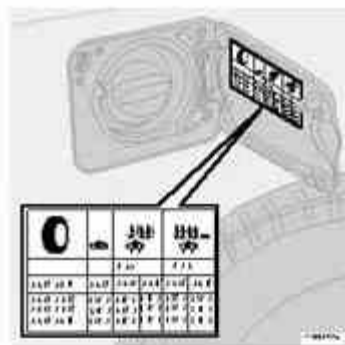

Tire pressure label

Checking and correcting tire pressure

- Check the tire pressure regularly.
- The tire pressure should be corrected only when the tires are cold.
- With warm tires, correct only when the pressure is too low. The tire temperature rises after driving just a few miles.

Vehicle loading

The tires on your Volvo will perform to specifications at all normal loads when inflated as recommended on the tire information label located on the inside of the fuel filler door*. This label also lists vehicle load limits. Do not load your car beyond the indicated limits.

WARNING!

Improperly inflated tires will reduce tire life, adversely affect vehicle handling and can possibly lead to failure resulting in loss of vehicle control without prior warning.

Temporary Spare

The spare tire in your car is called a "Temporary Spare". It has the following designation: T125/80 R17 (T135/90 R17 on the XC70).

At the recommended tire pressure shown on the inside of the fuel filler door, the tire may be used as a temporary replacement for a front or rear tire.

In the event of damage to this tire, a new one can be purchased from your Volvo retailer.

WARNING!

Current legislation prohibits the use of the "Temporary Spare" tire other than as a temporary replacement for a punctured tire. It must be replaced as soon as possible by a standard tire. Road holding and handling may be affected with the "Temporary Spare" in use. Do not exceed 50 mph (80 km/h). Do not drive farther than 50 miles (80 km) on a temporary spare tire.

CAUTION:

The car must not be driven with wheels of different dimensions or with a spare tire other than the one that came with the car. The use of different size wheels can seriously damage your car's transmission.

NOTE: Certain models may be equipped with a full-size spare tire. When used, it should be inflated to the same pressure as the tire it is replacing.

*Please note that the tire information label indicates pressure for both comfort and fuel economy.

pg. 111 Wheels and tires

Uniform tire quality grading

ALL PASSENGER CAR TIRES MUST CONFORM TO FEDERAL SAFETY REQUIREMENTS IN ADDITION TO THESE GRADES

Quality grades can be found, where applicable, on the tire sidewall between the tread shoulder and maximum section width. For example:

Treadwear 200 Traction AA Temperature A

TREADWEAR

The treadwear grade is a comparative rating based on the wear rate of the tire when tested under controlled conditions

on a specified government test course. For example, a tire graded 150 would wear one and one half (1 1/2) times as well on the government course as a tire graded 100. The relative performance of tires depends upon the actual conditions of their use, however, and many depart significantly from the norm due to variation in driving habits, service practices and differences in road characteristics and climate.

TRACTION

The traction grades, from highest to lowest, are AA, A, B, and C, as measured under controlled conditions on specified government test surfaces of asphalt and concrete. A tire marked C may have poor traction performance.

WARNING!

The traction grade assigned to this tire is based on braking (straight-ahead) traction tests and is not a measure of cornering (turning) traction.

TEMPERATURE

The temperature grades are AA (the highest), A, B, and C, representing the tire's resistance to the generation of heat and its ability to dissipate heat when tested under controlled conditions on a specified indoor laboratory test wheel. Sustained high temperature can cause the material of the tire to degenerate and reduce tire life, and excessive temperature can lead to sudden tire failure. The grade C corresponds to a minimum level of performance which all passenger car tires must meet under the Federal Motor Safety Standard No. 109. Grades B and A represent higher levels of performance on the laboratory test wheel than the minimum required by law.

WARNING!

The temperature grade for this tire is established for a tire that is properly inflated and not overloaded. Excessive speed, under-inflation, or excessive loading, either separately or in combination, can cause heat buildup and possible tire failure.

pg. 112 Changing wheels

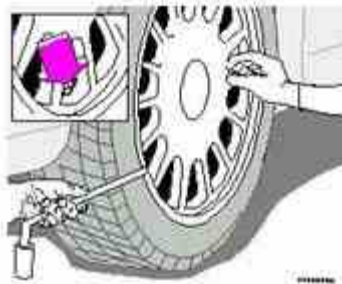

Insert flat end of lug wrench and turn/pull straight out

Changing wheels

The spare wheel is located under the carpet on the cargo area floor. The jack and crank are secured in the wheel recess. There are two jack attachment points on each side of the car.

To change a wheel:

- Engage the parking brake.
- Put the gear selector in (P)ark.
- Remove the wheel cap (where applicable) using the lug wrench in the tool kit.
- With the car still on the ground, use the lug wrench to loosen the wheel bolts 1/2 - 1 turn by exerting downward pressure. Turn the bolts counterclockwise to loosen.

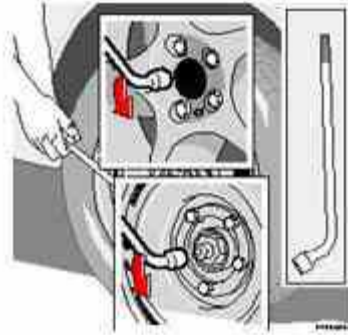

Loosen wheel bolts

- Position the jack on the bar in the attachment (A in the illustration in right column) and crank while simultaneously guiding the base of the jack to the ground. **The base of the jack must be flat on a level, firm, non-slippery surface. Before raising the car, check that the jack is still correctly positioned in the attachment.**
- Raise the vehicle until the wheel to be changed is lifted off the ground.
- Unscrew the wheel bolts completely and carefully remove the wheel so as not to damage the thread on the studs.

NOTE: See also [page 133](#) for hoisting the vehicle on a garage lift!

WARNING!

- The jack must correctly engage the bar in the jack attachment (A). The car's weight must not rest on the jack attachment (B). See illustration on [page 113](#).
- Be sure the jack is on a firm, level, non-slippery surface.
- Never allow any part of your body to be extended under a car supported by a jack.
- Use the jack intended for the car when replacing a wheel. For any other job, use stands to support the side of the car being worked on.
- Apply the parking brake and put the gear selector in the (P)ark position.
- Block the wheels standing on the ground, use rigid wooden blocks.

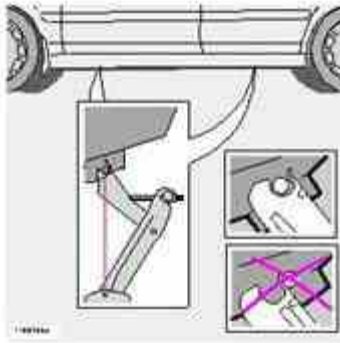

Attaching the jack

NOTE: To avoid excessive wear and the necessity of rebalancing, mark and reinstall wheels in the same location and position as before removal. To lessen the chance of imbalance, each wheel hub is equipped with a guide stud to ensure that a removed wheel can be reinstalled in its original position (as when changing over to winter tires/wheels).

NOTE: Refer to [page 133](#) for hoisting the vehicle on a garage lift.

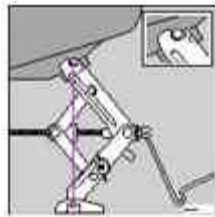

Jack for AWD models

CAUTION:

- The car must not be driven with wheels of different dimensions or with a spare tire other than the one that came with the car. The use of different size wheels can seriously damage your car's transmission.
- Correct tightening torque on wheel bolts must be observed. The wheel bolts should never be greased or lubricated. The extended, chromed wheel bolts must not be used with steel rims, as they make it impossible to fit the hub caps.

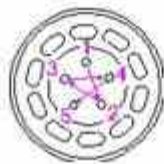

Correct tightening order for wheel bolts

Installing the wheel

- Clean the contact surfaces on the wheel and hub.
- Lift the wheel and place it on the hub. Make sure that you align the wheel with the guide stud on the wheel hub prior to installation.
- Install the wheel bolts and tighten hand-tight. Using the lug wrench, tighten crosswise (see illustration above) until all bolts are snug.
- Lower the vehicle to the ground and alternately tighten the bolts crosswise to 100 ft. lbs. (136 Nm).
- Install the wheel cap (where applicable).



[Contents](#) | [Top of Page](#)

2003 VOLVO V70

HomeLink® Universal Transceiver (option)

pg. 167 HomeLink® Universal Transceiver (option)

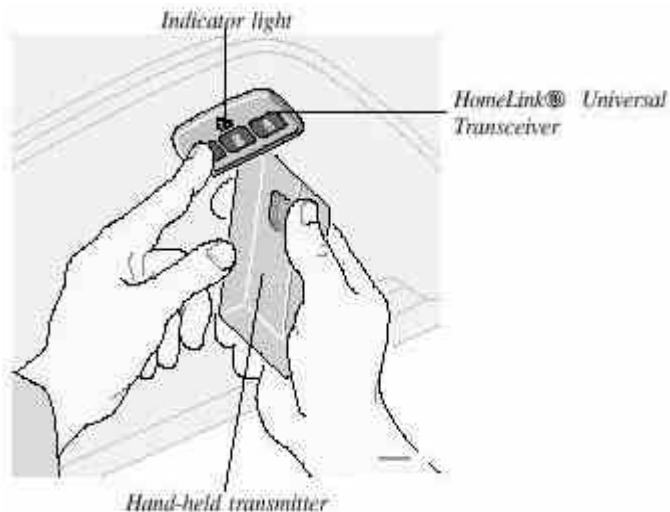

HomeLink® Universal Transceiver

HomeLink® is an advanced system that can be programmed to learn the codes of three different remote controlled devices (e.g., garage door openers, remote lighting, entry door lock). HomeLink®'s sun visor-mounted transceiver, powered by your car's electrical system, may then be used in place of your hand-held remote controls.

NOTE: For your security, the HomeLink® Universal Transceiver is designed to **not** function if you lock your car from the *outside*.

Programming the transceiver

1. The ignition switch must be turned to the "accessory" position (II) before programming the HomeLink® Universal Transceiver.
2. Begin by erasing all 3 factory default channels. Hold down the two outside buttons (buttons 1 and 3 in the illustration) on the HomeLink® Universal Transceiver for about 20 seconds, until HomeLink®'s indicator light begins to flash. Then release the buttons.
3. Hold your hand-held transmitter (garage door opener, for example) 2 to 5 in. (5 to 12 cm) away from the HomeLink® surface, keeping the indicator light in view. For placement questions, contact HomeLink® toll-free 1-800-355-3515 (Internet: www.HomeLink.com).
4. Using two hands, push and hold both your hand-held transmitter's button and the transceiver button you wish to program. The indicator light will flash first slowly, then rapidly. Rapid flashing tells you the HomeLink® button has

been successfully programmed. Release both buttons.

5. If you are programming a rolling code-equipped device (e.g., garage door opener or entry door lock), refer to "Programming rolling codes" on the next page to complete the programming process.

Repeat steps 3 and 4 to program the other two transceiver buttons.

If, after several attempts, you are unable to successfully train the HomeLink® Universal Transceiver to learn your hand-held transmitter's signal, contact HomeLink® toll-free 1-800-355-3515 (Internet: www.HomeLink.com).

WARNING!

- If you use HomeLink® to open a garage door or gate, be sure no one is near the gate or door while it is in motion.
- Do not use the HomeLink® Universal Transceiver with any garage door opener that lacks safety "stop" and "reverse" features as required by federal safety standards. (This includes any garage door opener model manufactured before April 1, 1982) A garage door opener that cannot "detect" an object, signalling the door to "stop" and "reverse" does not meet current federal safety standards. Using a garage door opener without these features increases the risk of serious injury or death. For more information on this matter, call toll-free 1-800-355-3515 (Internet: www.HomeLink.com).

pg. 168 HomeLink® Universal Transceiver (option)

NOTE - Canadian residents:

During programming, your hand-held transmitter may automatically stop transmitting. To successfully train HomeLink®, continue to hold the HomeLink® button. At the same time, repeatedly press and hold your hand-held transmitter's button at two-second intervals until HomeLink® has learned your transmitter's code. The HomeLink® indicator light will flash first slowly, and then rapidly to indicate that the button has been successfully programmed.

Determining if your garage door uses a rolling code

Determine, in one of the following ways, if your garage door uses a rolling code system and is manufactured after 1996:

- Refer to the garage door opener owner's manual for verification.
- If your hand-held transmitter appears to program the HomeLink® Universal Transceiver but the programmed button does not activate the garage door, your garage door opener may have a rolling code.
- Press the programmed HomeLink® button. If the garage door opener has the rolling code feature, the HomeLink® indicator light flashes rapidly and then glows steadily after approximately 2 seconds.

To train a rolling code garage door opener, follow these instructions after programming the desired transceiver button according to "Programming the transceiver." The help of a second person may make training easier.

1. Locate the training button on the *garage door opener motor head unit*. The location and color of the training button may vary. If you encounter difficulty, refer to the garage door opener owner's manual or call toll-free 1-800-355-3515 (Internet: www.HomeLink.com).
2. Press the "training" button on the garage door opener motor head unit until the "training" light comes on.
3. Press and release the programmed HomeLink® button. Press and release the programmed HomeLink® button a *second* time to complete the training process. Some garage door openers may require you to do this procedure a *third* time to complete the training.

The programmed button on your HomeLink® Universal Transceiver should now operate your garage door opener. The

original hand-held transmitter can also be used, as desired, to operate the garage door.

The remaining two HomeLink® buttons can be programmed in the same way. In the event of any problems in programming the HomeLink® Universal Transceiver, call toll-free 1-800-355-3515 (Internet: www.HomeLink.com).

Operating the HomeLink® Universal Transceiver

Once programmed, the HomeLink® Universal Transceiver can be used in place of your hand-held transmitters.

To operate, the key must be turned to the "accessory" position (II) or the engine must be running. Press the programmed HomeLink® button to activate the garage door, driveway gate, security lighting, home security system, etc.

Your original hand-held transmitters may, of course, be used at any time.

Erasing programmed buttons

Individual buttons cannot be erased. To erase all three programmed buttons:

1. Turn the ignition key to the "accessory" position (II).
2. Hold down the two outside buttons on the HomeLink® Universal Transceiver for about 20 seconds, until HomeLink®'s indicator light begins to flash.
3. Release both buttons.

The HomeLink® buttons can be reprogrammed using the procedures described on the previous page.

(HomeLink® information continues on the next page)

pg. 169 HomeLink® Universal Transceiver (option)

Reprogramming a single HomeLink® button

1. Press and hold the desired HomeLink® button. Do not release the button until step 3 has been completed.
2. When the indicator light begins to flash slowly (after approximately 20 seconds), position your hand-held transmitter 2 to 5 in. (5 to 12 cm) away from the HomeLink® surface.
3. Press and hold the hand-held transmitter button. The HomeLink® indicator light will flash first slowly, then rapidly. When the indicator light flashes rapidly, release both buttons.

The previously programmed device has now been erased and the new device can be activated by pressing the HomeLink® button that has just been programmed. This procedure will not affect any other programmed HomeLink® buttons.

NOTE:

- Retain the original transmitter(s) for future programming procedures (e.g., if you purchase a new car).
- For your own security, erase all programmed buttons on the HomeLink® Universal Transceiver when you sell your car.
- Metallic sun protection films should not be used on any windows in a car equipped with HomeLink® Universal Transceiver. This could interfere with the transceiver's function.



2003
VOLVO
V70

Chapter 8 - Maintenance/Serviceing

pg. 115 Maintenance/Serviceing

Fuses 116

Replacing bulbs 120

Paint touch up 126

Washing the car 127

Cleaning the upholstery 128

Maintenance service, Warranty 129

Fuel/emissions systems 130

Drive belt, Air pump system, Coolant 131

Emissions maintenance 132

Washer fluid reservoir, Hoisting the car 133

Opening the hood, Engine compartment 134

Engine oil 135

Power steering/Brake fluid reservoirs 137

Battery maintenance 138

Replacing wiper blades 140

pg. 116 Fuses

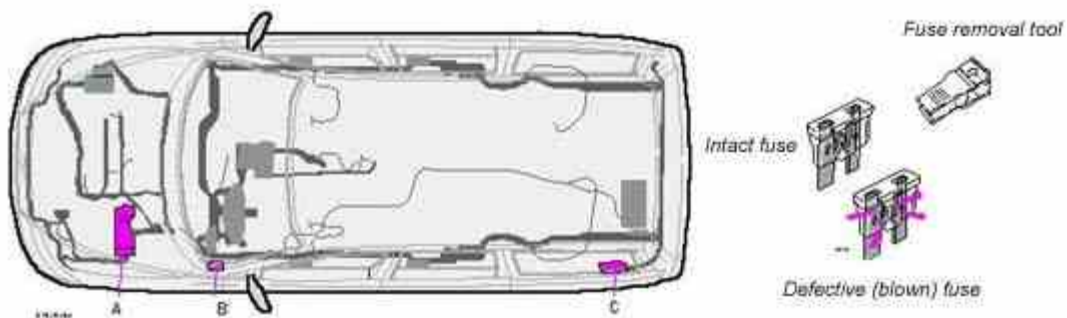

Replacing fuses

If an electrical component fails to function, it is possible that a fuse has blown due to a temporary circuit overload.

Fuses are located in different places:

- A** - Relays/fuse box in the engine compartment
- B** - Fuse box in the passenger compartment
- C** - Relays/fuse box in the cargo area

A label on the inside of each cover indicates the amperage and the electrical components that are connected to each fuse.

The easiest way to see if a fuse is blown is to remove it. Pull the fuse straight out. If a fuse is difficult to remove, you will find a special fuse removal tool in the passenger compartment fuse box. From the side, examine the curved metal wire to see if it is broken. If so, put in a new fuse of the **same color and amperage** (written on the fuse). Spare fuses are stored in the fuse box in the passenger compartment. If fuses burn out repeatedly, have the electrical system inspected by an authorized Volvo retailer.

WARNING!

Never use fuses with higher amperage than those stated on the following pages. Doing so could overload the car's electrical system.

pg. 117 Fuses in the engine compartment

Relays/fuses in the engine compartment

When replacing fuses, be sure to replace a blown fuse with a new one of the **same color and amperage** (written on the fuse). Fuse amperage is also indicated on the inside of the fuse box cover.

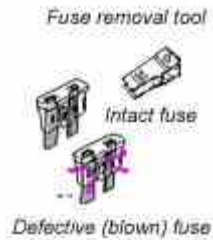

A - To open, press the plastic catches on the rear side of the fuse box cover and lift

Ordinary fuses

Location	Amperage
1 Accessories	25A
2 Auxiliary lamps (option)	20A
3 Vacuum pump	15A
4 Oxygen sensors	20A
5 Crankcase ventilation heater, solenoid valves	10A
6 Mass airflow sensor, engine control module, injectors	15A
7 Throttle module	10A
8 AC compressor, accelerator pedal position sensor, E-box fan	10A
9 Horn	15A
10 Tailgate wiper	10A
11 AC compressor, ignition coils	20A
12 Brake light switch	5A
13 Windshield wipers	25A
14 ABS/STC/DSTC	30A
15 -	
16 Windshield washers, headlight wiper/washers (certain models)	15A
17 Low beam, right	10A
18 Low beam, left	10A
19 ABS/STC/DSTC	30A
20 High beam, left	15A
21 High beam, right	15A
22 Starter motor	25A
23 Engine control module	5A
24 -	

pg. 118 Fuses in the passenger compartment

Fuse box in the passenger compartment

This fuse box is located at the far left side of the instrument panel. Extra fuses and the fuse removal tool are also stored here. When replacing a blown fuse, be sure to replace it with a new one of the **same color and amperage** (written on the fuse).

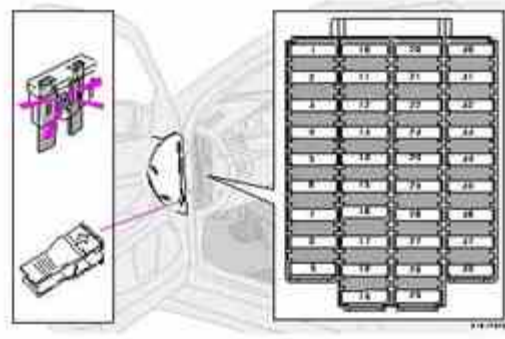

Location	Amperage
1 Low beam headlights	15A
2 High beam headlights	20A
3 Power driver's seat	30A
4 Power passenger's seat	30A
5 -	
6 -	
7 Heated seat - front left (option)	15A
8 Heated seat - front right (option)	15A
9 ABS/STC/DSTC	5A
10 -	
11 -	
12 Headlight wipers (certain models)	15A
13 Electric socket 12 V	15A
14 Power passenger's seat	5A
15 Audio system, VNS	5A
16 Audio system	20A
17 Audio amplifier	30A
18 Front fog lights	15A
19 VNS display	10A
20 -	
21 Automatic transmission, shiftlock, extended D2 feed	10A
22 Direction indicators	20A
23 Headlight switch module, climate control system, onboard diagnostic connector, steering wheel lever modules	5A
24 Relay for extended D1 feed: climate control system, power driver's seat, driver's info	10A
25 Ignition switch, relay starter motor, SRS, engine control module	10A
26 Climate control system blower	30A
27 -	
28 Electronic module - courtesy lighting	10A
29 -	
30 Left front/rear parking lights	7.5A
31 Right front/rear parking lights, license plate lights	7.5A
32 Central electrical module, vanity mirror lighting, power steering, glove compartment light, interior courtesy lighting	10A

33 Fuel pump	15A
34 Power sun roof	15A
35 Central locking system, power windows - left door mirror	25A
36 Central locking system, power windows - right door mirror	25A
37 Rear power windows, power child safety	30A
38 Alarm siren	5A

* Please be aware that if this fuse is not intact, or if it is removed, the alarm will sound.

pg. 119 Fuses in the cargo area

Fuses in the cargo area

The fuses in the cargo area are located on the trim on the left-hand side. When replacing a blown fuse, be sure to replace it with a new one of the same color and amperage (written on the fuse).

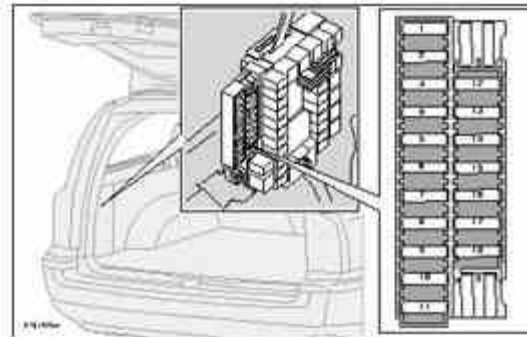
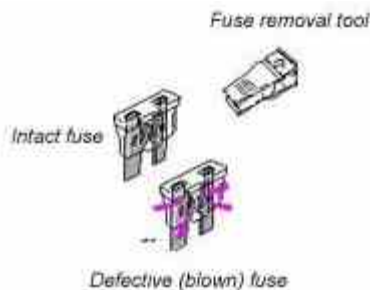

Ordinary fuses

Location	Amperage
1 Rear electrical module, cargo area lighting	10A
2 Rear fog light	10A
3 Brake lights	15A
4 Backup lights	10A
5 Rear window defroster, relay 15I - accessories	5A
6 Unlocking tailgate	10A
7 Auxiliary 12 volt socket in cargo area (option)	15A
8 Central locking rear doors/fuel filler door	20A
9 Trailer (30 feed)	15A
10 CD changer, VNS	10A
11 Accessory control module (AEM)	15A
12 Tailgate wiper	15A
13 Loudspeaker (subwoofer) cargo area - option	15A
14 Brake lights	7.5A
15 Trailer (15I feed)	20A
16 -	
17 All Wheel Drive control module	7.5A

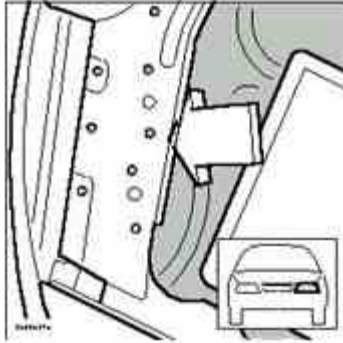

Replacing high/low beam headlight bulbs

The headlight bulbs must be replaced from the engine compartment.

CAUTION:

- Do not touch the glass on halogen bulbs with your fingers. Grease, oil or any other impurities can be carbonized onto the bulb and cause damage to the reflector.
- Be sure to use bulbs of the correct type and voltage.

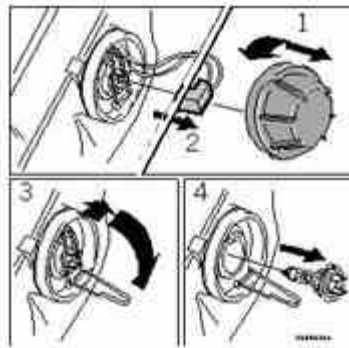

Removing a defective bulb

To remove a defective low beam bulb:

- Switch off all lights and turn the ignition switch to position 0.
- Open the hood.
- Remove the plastic cover over the bulb (1) by turning it counterclockwise.
- Remove the connector (2).
- Loosen the retaining spring (3) by first moving it to the right and then moving it down, out of the way.
- Pull out the defective bulb. Note the position of the guide lug on the base of the bulb (4).

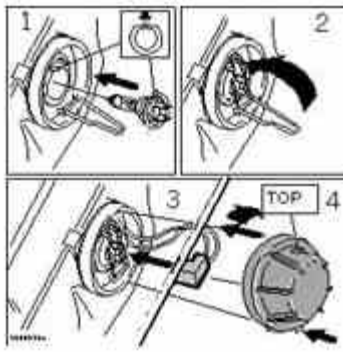

Installing a new bulb

To install a new low beam bulb (H7):

- Insert the new bulb, without touching the glass, with the guide lug upward (1). The bulb will only seat properly in this position.
- Move the retaining spring up and push it slightly to the left until it seats properly (2).
- Press the connector into place on the bulb (3).
- Reinstall the plastic cover and turn it clockwise until it is correctly in place (4). "TOP" must be upward.

NOTE: If the vertical aim of your headlights needs to be adjusted for any reason (e.g., towing a trailer for extended periods), this should be done by an authorized Volvo retailer.

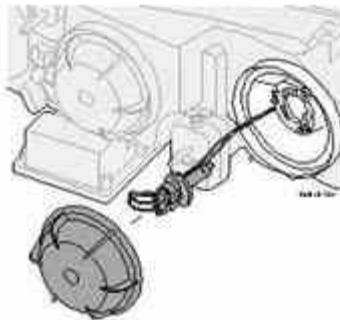

To remove and install a high beam bulb (HB3):

- Switch off all lights and turn the ignition switch to position 0.
- Open the hood.
- Remove the cover by twisting it counterclockwise.
- Twist the bulb holder counterclockwise, pull it out and fit a new bulb. Note its position.
- Refit the bulb holder. It can only be fitted in one way.
- Screw the cover back on. The word TOP should be upwards.

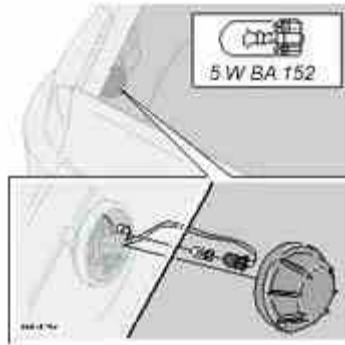

Replacement of front parking light bulb

- Switch off all lights and turn ignition key to position 0.
- Remove the low beam cover by twisting counterclockwise.
- Pull out the bulb and its socket. Replace bulb.
- Press the bulb and its socket back into place.
- Check that the new bulb lights.
- Screw the cover back into place, "TOP" should be upwards!

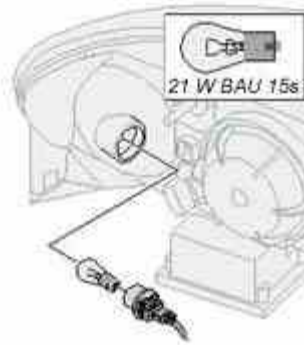

Changing the bulb in the turn signals at the front corners

- Switch off all lights and turn ignition key to position 0.
- Pull out the bulb and its socket by twisting counterclockwise. Replace bulb.
- Press the bulb and its socket back into place.
- Check that the new bulb lights.

pg. 122 Replacing bulbs

Replacement of bulbs in backup light, rear parking lights and rear fog lights

- Switch off all lights and turn the ignition switch to position 0.
- Open the access panel.
- Remove the sound insulation behind it.
- Twist the bulb holder counterclockwise and remove it.
- Press the bulb inward, twist it counterclockwise and extract it.
- Fit a new bulb.
- Fit the bulb holder in place and twist it clockwise.

- Refit the sound insulation and put the access panel back in place.

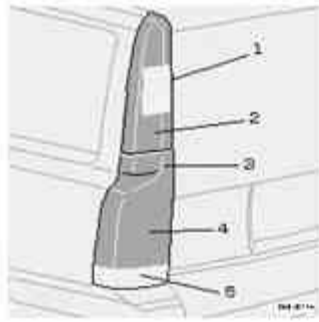

- | | |
|---|-----------------|
| 1. Rear turn signals | 21 W BAU 15 s |
| 2. Brake light | 21 W BA 15 s |
| 3. Rear parking lights | 5 W BA 15 s |
| 4. Rear fog light (left side only)
and rear parking lights | 21W/4W BAY 15 d |
| 5. Backup light | 21 W BA 15 s |

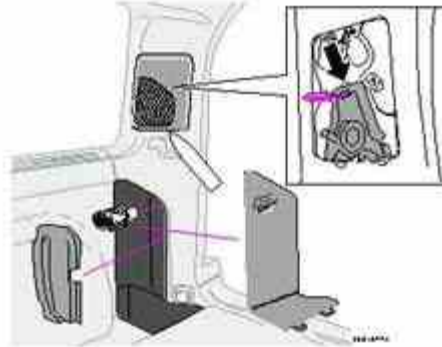

Replacement of rear turn signal and brake light bulbs

- Switch off all lights and turn the ignition switch to position 0.
- Using a screwdriver, carefully pry off the speaker grille.
- Pull out the red tab in the speaker.
- Then press on the black pin above the extracted red tab and twist out the speaker.
- Twist the bulb holder counter-clockwise, and withdraw it.
- Fit a new bulb.
- Fit the bulb holder in place and twist it clockwise.
- Refit the speaker and press in the red tab.
- Press the speaker grille back into position.

pg. 123 Replacing bulbs

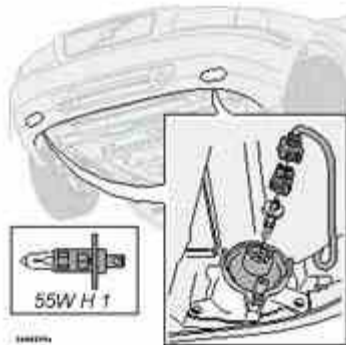

Front fog lights (option)

CAUTION:

Avoid touching the glass on the bulb with your fingers.

- Switch off all lights and turn the ignition key to position 0.
- Turn the bulb holder slightly counterclockwise to release it.
- Replace the bulb. The shape of the base of the bulb corresponds to the shape of the bulb holder.
- Reinstall the bulb holder by turning it slightly clockwise. "TOP" on the holder should be upward.



Side direction indicator

- Open the front door halfway.
- From the inside of the fender, push the lamp housing out.
- Turn the bulb holder 1/4 turn counterclockwise and pull it out from the lens.
- Remove the defective bulb by pulling it straight out.
- Insert a new bulb.
- Reinsert the bulb holder in the lens and press the entire unit back into place on the fender.

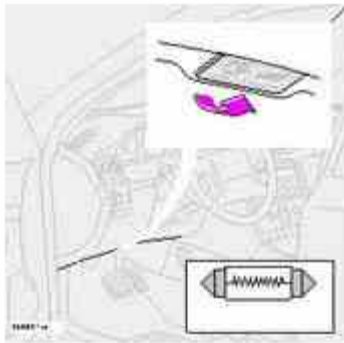

Door step courtesy lights

The door step courtesy lights are located under the dash on the driver's and passenger's sides.

To replace a bulb:

- Carefully insert a screwdriver and pry out the lens.
- Replace the defective bulb.
- Reinstall the lens.

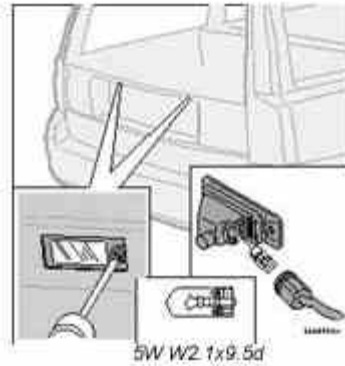

License plate lights

- Switch off the ignition.
- Loosen the screws with a Torx screwdriver.
- Carefully pull out the lamp housing.
- Turn the bulb holder counterclockwise and pull it out.
- Pull out the defective bulb and insert a new one.
- Reinsert the bulb holder into the housing and turn it clockwise.
- Reinstall the housing and screw it in place.

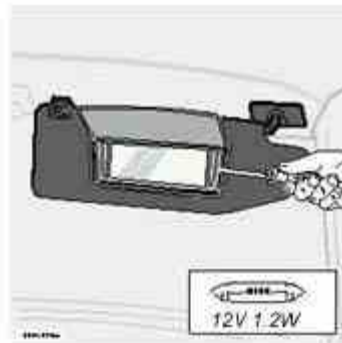

Vanity mirror lights

- Carefully insert a screwdriver and pry out the lens.
- Pry out the defective bulb and replace it.
- Carefully press the lower edge of lens onto the four tabs and press the upper edge of the lens into place.



Front courtesy lights

These bulbs may be difficult for you to replace yourself. We recommend that you let an authorized Volvo retailer replace these bulbs if necessary.

pg. 125 Replacing bulbs



Rear reading lights

These bulbs may be difficult for you to replace yourself. We recommend that you let an authorized Volvo retailer replace these bulbs if necessary.

NOTE: Other bulbs may be difficult for you to replace yourself. Let an authorized Volvo retailer replace these bulbs if necessary.

pg. 126 Paint touch up

Paint touch-up

Paint damage requires immediate attention to avoid rusting. Make it a habit to check the finish regularly - when washing the car for instance. Touch-up if necessary.

Paint repairs require special equipment and skill. Contact your Volvo retailer for any extensive damage.

Minor scratches can be repaired by using Volvo touch-up paint.

NOTE: When ordering touch-up paint from your Volvo retailer, use the paint code indicated on the model plate. The plate is located in the engine compartment.

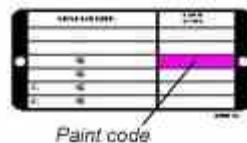

Minor stone chips and scratches

Material:
Primer - can
Paint - touch-up bottle
Brush

Masking tape

NOTE: When touching up the car, it should be clean and dry. The surface temperature should be above 60° F (15° C).

Minor scratches on the surface

If the stone chip has not penetrated down to the metal and an undamaged layer of paint remains, the touch-up paint can be applied as soon as the spot has been cleaned.

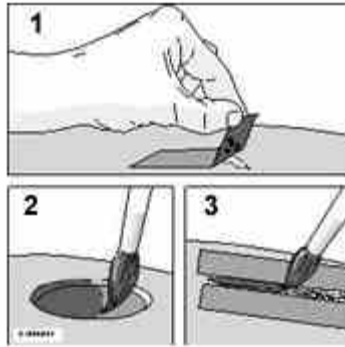

Deep scratches

1. Place a strip of masking tape over the damaged surface. Pull the tape off so that any loose flakes of paint adhere to it.
2. Thoroughly mix the primer and apply it with a small brush. When the primer surface is dry, the paint can be applied using a brush. Mix the paint thoroughly; apply several thin paint coats and let dry after each application.
3. If there is a longer scratch, you may want to protect surrounding paint by masking it off.

pg. 127 Washing the car

Washing the car

- The car should be washed at regular intervals since dirt, dust, insects and tar spots adhere to the paint and may cause damage. It is particularly important to wash the car frequently in the wintertime to prevent corrosion, when salt has been used on the roads.
 - When washing the car, do not expose it to direct sunlight. Use lukewarm water to soften the dirt before you wash with a sponge and plenty of water, to avoid scratching.
 - **Bird droppings:** Remove from paintwork as soon as possible. Otherwise the finish may be permanently damaged.
 - A detergent can be used to facilitate the softening of dirt and oil.
 - A water-soluble grease solvent may be used in cases of sticky dirt. However, use a wash place equipped with a drainage separator.
 - Remove dirt from the drain holes in the doors and rocker panels.
 - Dry the car with a clean chamois.
 - Tar spots can be removed with kerosene or tar remover after the car has been washed.
 - A stiff-bristle brush and lukewarm soapy water can be used to clean the wiper blades. Frequent cleaning improves visibility considerably.
 - Wash off the dirt from the underside (wheel housings, fenders, etc.).
 - In areas of high industrial fallout, more frequent washing is recommended.
-

CAUTION:

During high pressure washing, the spray mouthpiece must never be closer to the vehicle than 13" (30 cm). Do not spray into the locks.

Special sun roof cautions:

- Always close the sun roof and sun shade before washing your vehicle.
- Never use abrasive cleaning agents on the sun roof.
- Never use wax on the rubber seals around the sun roof.

-
- When washing or steam cleaning the engine, avoid spraying water or steam directly on the electrical components or toward the rear side of the engine.
 - After cleaning the engine, the spark plug wells should be inspected for water and blown dry if necessary.

Suitable detergents: Special car washing detergents should be used. Mix according to manufacturer's instructions.

Bumpers: The bumpers are painted. Wash the bumpers with the same cleaning agent used on the rest of the car. Never clean the bumpers with gasoline or paint thinner. Difficult spots can be removed with denatured alcohol. To avoid scratches, do not dry the bumpers with paper.

WARNING!

- When the car is driven immediately after being washed, apply the brakes several times in order to remove any moisture from the brake linings.
- Engine cleaning agents should not be used when the engine is warm. This constitutes a fire risk.

pg. 128 Washing the car, Cleaning the upholstery

Automatic washing - simple and quick

- **We do NOT recommend washing your car in an automatic wash during the first six months (because the paint will not have hardened sufficiently).**
- An automatic wash is a simple and quick way to clean your car, but it is worth remembering that it may not be as thorough as when you yourself go over the car with sponge and water. Keeping the underbody clean is most important, especially in the winter. Some automatic washers do not have facilities for washing the underbody.
- Before driving into an automatic wash, make sure that side view mirrors, auxiliary lamps, etc, are secure, otherwise there is risk of the machine dislodging them.

Polishing and waxing

- Normally, polishing is not required during the first year after delivery. However, waxing may be beneficial.
- Before applying polish or wax the car must be washed and dried. Tar spots can be removed with kerosene or tar remover. Difficult spots may require a fine rubbing compound.
- After polishing, use liquid or paste wax.
- Several commercially available products contain both polish and wax.
- Waxing alone does not substitute for polishing of a dull surface.
- A wide range of polymer-based car waxes can be purchased today. These waxes are easy to use and produce a long-lasting, high-gloss finish that protects the bodywork against oxidation, road dirt and fading.
- Do not polish or wax your car in direct sunlight (the surface of the car should not be warmer than 113° F (45° C)).

Cleaning the upholstery

- The **fabric** can be cleaned with soapy water or a detergent. For more difficult spots caused by oil, ice cream, shoe polish, grease, etc., use a clothing/fabric stain remover.
- The **plastic** in the upholstery can be cleaned with a soft cloth and mild soap solution.
- **Leather upholstery/suede-like upholstery (alcantera™)** can be cleaned with a soft cloth and mild soap solution. For more difficult spots, Volvo offers a leather care kit.
- **Under no circumstances should gasoline, naphtha or similar cleaning agents be used on the plastic or the leather since these can cause damage.**

Cleaning the seat belts

Clean only with lukewarm water and mild soap solution.

Cleaning floor mats

The floor mats should be vacuumed or brushed clean regularly, especially during winter, when they should be taken out for drying. Spots on textile mats can be removed with a mild detergent.

Stain removal

- Take extra care when removing stains such as ink or lipstick since the coloring can spread.
- Use solvents sparingly. Too much solvent can damage the seat padding.
- Start from the outside of the stain and work toward the center.

pg. 129 Maintenance service, Warranty

Maintenance service

Volvo advises you to follow the service program outlined in the Warranty and Service Records Information booklet. This maintenance program contains inspections and services necessary for the proper function of your car. The maintenance services contain several checks which require special instruments and tools and therefore must be performed by a qualified technician. To keep your Volvo in top condition, specify time-tested and proven Genuine Volvo Parts and Accessories.

The Federal Clean Air Act - U.S.

The Federal Clean Air Act requires vehicle manufacturers to furnish written instructions to the ultimate purchaser to assure the proper servicing and function of the components that control emissions. These services, which are listed in the "Warranty and Service Records Information booklet," are not covered by the warranty. You will be required to pay for labor and material used.

Maintenance services

Your Volvo passed several major inspections before it was delivered to you, in accordance with Volvo specifications. The maintenance services outlined in the Warranty and Service Records Information booklet, many of which will positively affect your vehicle's emissions, should be performed as indicated. It is recommended that receipts for vehicle emission services be retained in case questions arise concerning maintenance.

Inspection and service should also be performed anytime a malfunction is observed or suspected.

[Page 128](#) provides information about maintenance of emission-related components.

Applicable warranties - U.S.

In accordance with applicable U.S. and Canadian regulations, the following list of warranties is provided.

- New Car Limited Warranty
- Parts and Accessories Limited Warranty
- Corrosion Protection Limited Warranty
- Seat Belt and Supplemental Restraint Systems Limited Warranty
- Emission Design and Defect Warranty
- Emission Performance Warranty

These are the Federal warranties; other warranties are provided as required by state/provincial law. Refer to your separate Warranty and Service Records Information booklet for detailed information concerning each of the warranties.



[Contents](#) | [Top of Page](#)

2003 VOLVO V70

Chapter 9 - Specifications

pg. 141 Specifications

[Label information](#) [142](#)

[Dimensions and weights](#) [143](#)

[Engine specifications](#) [144](#)

[Transmission specifications](#) [145](#)

[Oil/fluid specifications and volumes](#) [146](#)

[Fuel system, Distributor ignition system, Suspension](#) [147](#)

[Electrical system](#) [148](#)

[Volvo On Call](#) [149](#)

pg. 142 Label information

1 Vehicle Emission Control Information

Your Volvo is designed to meet all applicable emission standards, as evidenced by the certification label on the underside of the hood. For further information regarding these regulations, please consult your Volvo retailer.

2 Vacuum hose routing

(underside of hood)

3 Loads and Tire Pressures

(on inside of fuel filler door)

4 Model plate

Vehicle Identification Number (VIN). Codes for color and upholstery, etc. The plate is located in the engine compartment, on the inside of the left front fender.

5 Vehicle Identification Number (VIN) *

The VIN plate is located on the top left surface of the dashboard. The VIN is also stamped on the right hand door pillar.

6 Federal Motor Vehicle Safety Standards (FMVSS) specifications (USA) and Ministry of Transport (CMVSS) standards (Canada)

Your Volvo is designed to meet all applicable safety standards, as evidenced by the certification label on the facing side of the driver's door. For further information regarding these regulations, please consult your Volvo retailer.

7 Child safety latch label

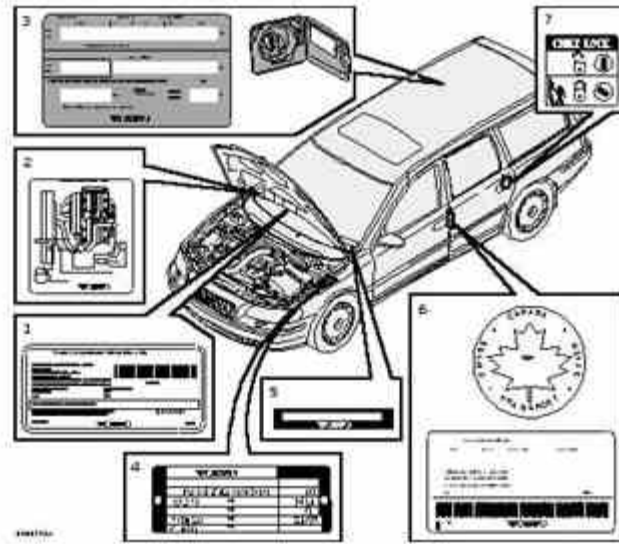

* The Vehicle Identification Number (VIN) should always be quoted in all correspondence concerning your vehicle with the retailer and when ordering parts.

All specifications are subject to change without prior notice.

pg. 143 Dimensions and weights

Dimensions

Length - 185.4 in. (471 cm), XC70 - 186.2 (473 cm)

Width - 71 in. (180 cm), XC70 - 73.2 in. (186 cm)

Height - 57.5 in. (147 cm), V70 AWD - 58.7 in. (149 cm), XC70 - 61.5 in. 156 cm)

Wheelbase - 108.5 in. (276 cm), XC70 - 108.8 in. (276 cm)

Track, front - 61.5 in. (156 cm), XC70 - 63.4 in. (161 cm)

Track, rear - 61.4 in. (156 cm), XC70 - 60.9 in. (155 cm)

Turning circle (between curbs) - 35.8-39 ft. (10.9-11.9 m)

Cargo capacity - 17.1 cu. ft. (0.48 m³)¹

- 26.3 cu. ft. (0.74 m³)²

- 58.0 cu. ft. (1.64 m³)³

	USA	Canada
Max roof load	220 lbs	100 kg
Max trailer weight (w/o brakes)	1100 lbs	500 kg
Max trailer weight*		
- (with brakes, 2" ball)	3300 lbs	1500 kg
- (with brakes, 1 7/8" ball)	2000 lbs	900 kg
Max tongue weight *	165 lbs	75 kg

WARNING!

When adding accessories, equipment, luggage and other cargo to your vehicle, the total loaded weight capacity of the vehicle must not be exceeded.

- 1) Rear seat backrest up, load height - upper edger of backrest
- 2) Rear seat backrest folded down, load height - upper edge of front seat backrests/lower edge of rear window
- 3) Rear seat backrest folded down, load height - headlining (ceiling)

Weights	USA	Canada
Gross vehicle weight (GVW)		
V70 man.	4630 lbs	2100 kg
V70 aut.	4690 lbs	2130 kg
V70 Turbo man.	4670 lbs	2120 kg
V70 Turbo aut.	4730 lbs	2150 kg
V70 AWD	4890 lbs	2220 kg
XC70	4890 lbs	2220 kg
Capacity weight ***	930 lbs	420 kg
Curb weight		
V70	3390-3585 lbs	1541-1632 kg
V70 AWD	3690-3725 lbs	1675-1695 kg
XC70	3765-3800 lbs	1710-1730 kg
Permissible axle weight, front		
V70 man.	2290 lbs	1040 kg
V70 aut.	2330 lbs	1060 kg
V70 Turbo aut.	2400 lbs	1090 kg
V70 AWD	2400 lbs	1090 kg
XC70	2490 lbs	1130 kg
Permissible axle weight, rear		
V70, V70 Turbo	2470 lbs	1120 kg
V70 AWD	2580 lbs	1170 kg
XC70	2620 lbs	1190 kg

* When driving for prolonged periods at temperatures above 86° F (30° C), the maximum recommended weight is 2000 lbs (900 kg).

**See also section "Trailer towing"

*** The max permissible axle loads or the gross vehicle weight must not be exceeded.

All specifications are subject to change without prior notice.

pg. 144 Engine specifications

Engine specifications

Designation: Volvo B 5234 T3

Output	247 hp at 5200 rpm (184 kW/87 rps)
Max. torque	243 ft. lbs. at 2400-5200 rpm (330 Nm/42-87 rps)

Number of cylinders	5
Bore	3.19" (81 mm)
Stroke	3.54" (90 mm)
Displacement	2.3 liters
Compression ratio	8.5:1
Number of valves	20

Designation: Volvo B 5254 T2

Output	208 hp at 5000 rpm (154 kW/83 rps)
Max. torque	236 ft. lbs. at 1500-4500 rpm (320 Nm/25-75 rps)
Number of cylinders	5
Bore	3.27" (83 mm)
Stroke	3.67" (93.2 mm)
Displacement	2.5 liters
Compression ratio	9.0:1
Number of valves	20

Designation: Volvo B 5244 T3

Output	197 hp at 6000 rpm (147 kW/100 rps)
Max. torque	210 ft. lbs. at 1800-5000 rpm (285 Nm/30-83 rps)
Number of cylinders	5
Bore	3.27" (83 mm)
Stroke	3.54" (90 mm)
Displacement	2.4 liters
Compression ratio	9.0:1
Number of valves	20

Designation: Volvo B 5244 S

Output	168 hp at 6000 rpm (125 kW/100 rps)
Max. torque	166 ft. lbs. at 4500 rpm (225 Nm/75 rps)
Number of cylinders	5
Bore	3.27" (83 mm)
Stroke	3.54" (90 mm)
Displacement	2.4 liters
Compression ratio	10.3:1
Number of valves	20

Charge air cooler (Intercooler)

Turbocharged engines employ a turbo-compressor to force air into the engine inlet manifold and a charge air cooler to cool the compressed inlet air. The resulting increase in air flow raises pressure in the intake manifold and increases engine power over that developed by a normally-aspirated engine. The charge air cooler (which resembles a radiator) is located between the turbo-compressor and inlet manifold.

Power transmission

Manual transmission: M 56 LK

Single-disc dry plate clutch. All-synchromesh on all gears including reverse; integrated final drive. Operation via a floor mounted gear lever.

Final drive ratio 4.00:1

Reduction ratios

1st gear 3.39:1

2nd gear 1.91:1

3rd gear 1.19:1

4th gear 0.87:1

5th gear 0.70:1

Reverse 3.30:1

Automatic transmission: AW 55-50

5-speed automatic electronically controlled gearbox comprising a hydraulic torque converter with a lock-up function; planetary gear, integrated final drive.

Operation via a floor mounted gear selector lever. Drive shafts with symmetrical joint location. Overdrive.

Final drive ratio 2.44:1*

Reduction ratios AW5

1st gear 4.77:1

2nd gear 2.10:1

3rd gear 1.96:1

4th gear 1.32:1

5th gear 1.02:1

Reverse 3.23:1

* XC70 2.65:1

Engine Oil

Meeting or exceeding ILSAC specification GF-2, including ACEA A1, API SJ, SJ/CF, and SJ/Energy Conserving.

Oil additives must not be used.

Volume:

Capacity (including oil filter): 6.1 US qts. (5.8 liters)

Automatic Transmission Fluid

AW5: Only Volvo gearbox oil (1161540-8). Do not mix with other oils.

Volume: 7.9 US qts (7.5 liters)

Cooling system

Type: Positive pressure, closed system. The thermostat begins to open at 194 °F (90 °C)

Coolant: Volvo original coolant/antifreeze

All specifications are subject to change without prior notice.

Power steering fluid

ATF fluid

Volume: 0.95 US qts (0.9 liters)

Brake fluid

DOT 4+ boiling point >536°F(280°C), P/N 9437433

Volume: 0.64 US qts (0.6 liters)

Climate control system - refrigerant (R 134a)

Oil: PAG

Volume: 2.2 lbs (1,000 g) R134a

Fuel

Minimum octane requirement - AKI 87 (RON 91)

Volume (fuel tank): 18.5 US gals (70 liters) or 19 US gals (72 liters) on models equipped with All Wheel Drive.

Washer fluid reservoir

Volume: 4.7 US qts (4.5 liters)

All specifications are subject to change without prior notice.

pg. 147 Fuel system, Distributor ignition system, Suspension

Fuel system

The engine is equipped with a multiport fuel injection system.

Distributor ignition system

Firing order: 1-2-4-5-3

Electronic ignition setting: Not adjustable

Spark plugs: Champion RC8PYP 8 (or equivalent)

Spark plug gap: 0.028-0.032" (0.7-0.8 mm)

Tightening torque: 18.4 ft. lbs. (25 Nm)

WARNING!

The ignition system operates at very high voltages. Special safety precautions must be followed to prevent injury.

Always turn the ignition off when:

- Replacing ignition components e.g. plugs, coil, etc.
- Do not touch any part of the ignition system while the engine is running. This may result in a shock and bodily injury.

Front suspension

Spring strut suspension with integrated shock absorbers and control arms linked to the support frame. Power-assisted rack and pinion steering. Safety type steering column. The alignment specifications apply to an unladen car but include fuel, coolant and spare wheel.

Rear suspension

Individual rear wheel suspension with longitudinal support arms, double link arms and track rods.

All specifications are subject to change without prior notice.

pg. 148 Electrical system

Electrical system

12 Volt, negative ground.

Voltage-controlled generator. Single-wire system with chassis and engine used as conductors. Grounded on chassis.

Battery

Voltage: 12 Volt, capacity: 600 A/115 min reserve capacity.

The battery contains corrosive and poisonous acids. It is of the utmost importance that old batteries are disposed of correctly. Your Volvo retailer can assist you in this matter.

Generator

Rated output: max. current: 140 A

Starter motor:

Output: 1.7 kW

Bulbs

Bulb	US no.	Power	Socket
Headlights			
- High beam	HB3	60W	-
- Low beam	H7	55W	-
Front parking lights		5W	W2.1x9.5d
Front direction indicators	(yellow)	21 W	BAU 15d
Front fog lights	H1	55 W	-
Rear direction indicators	(yellow)	21W	BAU 15 s
Tail lights	67	5W	BA 15 s

Brake lights	1156	21W	BA 15 s
Backup lights	1156	21W	BA 15 s
Rear fog light/rear parking lights		21/4W	BA 15 s
License plate light	-	5 W	W 2.1x9.5d
Door step courtesy lights			
Front	-	5W	SV 8.5
Cargo area lights	-	5 W	SV 8.5
Glove compartment light	-	2 W	BA 9s
Vanity mirror light(s)	-	12V 1.2W -	
Instrument lighting	-	3 W	W 2.1x9.5d

All specifications are subject to change without prior notice.

pg. 149 Volvo On Call



Your new Volvo comes with a four year ON CALL road assistance. Additional information, features, and benefits are described in a separate information package in your glove compartment.

If you have misplaced your package, dial:

In the U.S.A.

1-800-63-VOLVO (1-800-638-6586)

In Canada:

1-800-263-0475



Technician certification

In addition to Volvo factory training, Volvo supports certification by the National Institute for Automotive Excellence (A.S.E.). Certified technicians have demonstrated a high degree of competence in specific areas. Besides passing exams, each technician must also have worked in the field for two or more years before a certificate is issued. These professional technicians are best able to analyze vehicle problems and perform the necessary service procedures to keep your Volvo at peak operating condition.

All specifications are subject to change without prior notice.



2003 VOLVO V70

INDEX

pg. 171 - 174 Index

A	
ABS	19
ABS - warning light	29
Accessory lights	31
Adjusting the steering wheel	35
Advanced User Mode (AUM) - radio	159
Air conditioning	48 - 51
Air filter - engine	132
Air pump system	131
Air vents	46
Airbag (SIPS)	8
Airbag (SRS)	4
Alarm	80, 81
Alarm - "panic" function	80
All Wheel Drive	
- general information	94
- using snow chains	109
ALR/ELR	14
Anti-lock Brake System (ABS)	19
Anti-lock Brake System - warning light	29
Antifreeze	104, 131
Approach lighting	76
Armrest (center) - 3-section rear seat	65
Ashtray	39, 59
Audio systems	151
- cassette deck	162
- CD player	160
- HU-613 - overview	152
- HU-803 - overview	153
- specifications	165
AUM (Advanced User Mode) - radio	159
Automatic car washing	128

Automatic Locking Retractor (ALR)	14
Automatic transmission	90, 91, 145
- Geartronic	92, 93
- Kickdown	91, 92
Automatic transmission - cold starts	91
Auxiliary socket	31, 39
AWD	
- general information	94
- using snow chains	109
B	
Backrest (center) - 3-section rear seat	64
Battery	104, 148
Battery maintenance	138, 139
- Replacing the battery	139
- Ventilation hose	139
Booster cushion	12, 16
Brake failure warning light	28
Brake fluid	137
Brake system	18
Bulbs (list)	148
Bulbs - replacing	120-125
C	
Capacities (oils and fluids)	141, 146
Cargo compartment cover	71
Cargo compartment lighting	67
Cargo eyelets	68
Cargo net	69
Catalytic converters - three-way	106
Center armrest - 3-section rear seat	65
Center backrest (3-section rear seat)	64
Center console - switches	31
Center head restraint - 3-section rear seat	64
Center head restraint - rear seat	3
Center seat head restraint	63
Central locking buttons	79
Chains - winter driving	109
Changing wheels	112, 113
Child booster cushion	12, 16
Child Restraint Anchorages	15
Child safety	11, 12, 14, 16
Child safety locks - rear doors	82
Climate controls	48-51
Climate system - general information	47
Clock	27

Clutch interlock	89
Coat hanger	61
Coin compartment	59
Cold weather driving	104
Combination filter	48, 51
Coolant	131
Cooling system - general information	96
Courtesy light	74
Courtesy lights (front) - replacing	124
Courtesy lights - exterior	76
Cruise control	33
Cup holder	59
Cup holder in the center console	60
D	
Detachable trailer hitch - installing	102
Dimensions	143
Direction indicators	36
Distributor ignition system	147
Door step courtesy lights - replacing	123
Doors and locks	76
Drive belt	131
Driver's seat and remote keyless entry system	57
Driving economy	95
Driving mode indicator	27
Driving mode W	91, 93, 104
Driving with trunk open	96
E	
Economical driving	95
Electric socket in cargo compartment	67
Electrical system	148
Electrical system - general information	96
Electrically operated front seats	56
Electrically operated sideview mirrors	41
Electrically operated sun roof	42
Electrically operated windows	40
Electronic Brake Force Distribution	19
Electronic Climate Control (ECC)	48 - 51
Emergency Locking Retractor (ELR)	14
Emergency towing	99, 100
Emergency warning flashers	38
Emissions systems	130
Engine - specifications	144, 145
Engine - starting	87, 88
Engine air filter	132

Engine compartment	134
Engine oil	104, 135, 136
Extension of cargo compartment	63
Exterior courtesy lights	76
Exterior features - overview	25
Extra seat	73
F	
Fog light - rear	29, 34
Fog lights - front	34
Folding passenger's seat backrest	57
Foldtable	62
Front airbags - SRS	4 - 7
Front airbags - SRS - warning light	28
Front courtesy lights - replacing	124
Front fog lights	34
Front fog lights - replacing	124
Front reading lights	74
Front seats - adjusting	56
Front seats - heated	38
Front seats - manual adjustment	58
Front suspension	147
Fuel	84
Fuel filler cap	86
Fuel filter	132
Fuel gauge	27
Fuel requirements	84
Fuel system	130, 132, 147
Fuel tank cover	86
Fuel/emissions systems	130
Fuses	116-119
G	
Gas cap	86
Gasoline	84
Gear indicator	27
Geartronic (automatic transmission)	92, 93
Generator	148
Generator warning light	28
H	
Hand brake	39
Handgrip - XC70	55, 73
Handling	95
Hazard warning flashers	38
Head restraint (center) - 3-section rear seat	64
Head restraint - center rear	3

Headlight bulbs - replacing	120
Headlight wiper blades - replacing	140
Headlights	34
Heated front seats	38
Heated rear window	38
Heated sideview mirrors	38
Heating	48-51
Hoisting the car	133
Holder for grocery bags	67
Home Safe System	76
HomeLink®	167-169
Hood - opening	134
I	
Ignition switch	35
Immobilizer (start inhibitor)	76, 87
Indicator lights	28, 29
Inflatable curtain (IC)	9
Instrument illumination	34
Instrument panel	27
Instruments	26
Integrated booster cushion	12
Interior Air Quality system	51
Interior features - overview	24
Interior lighting	74
J	
Jack	72, 112
Jump starting	103
K	
Key - removing from ignition switch	87
Keyless entry system	77, 78
Keyless entry system - replacing batteries	78
Keylock	87
Keys	76
Kickdown	91, 92
L	
Label information	142
License plate lights - replacing	124
Lifting the car	133
Lights - accessory	31
Load carriers	97
Locking and unlocking the car	76
Locking steering wheel	35
Long distance trip	105
Long loads	57

M

Maintenance schedule	129
Malfunction indicator lamp	29
Manual climate control with air conditioning	52-54
Manual transmission	89, 145
Memory function - front seats	56
Mirrors	41
Mirrors, sideview - memory function	41

N

Net - cargo	69
Nylon cargo net	69

O

Occupant safety	17
Octane rating	84
Odometer	27
Oil - engine	104, 135, 136
Oil pressure warning light	28
Opening the hood	134

P

Paint touch-up	126
Panic function (alarm)	80
Parking brake	39
Parking brake reminder light	28
Parking lights	34
Passenger's seat backrest - folding	57
PCV system	132
Pen holder	61
Polishing	128
Power seats	56
Power steering fluid	137
Power windows	40

R

Radio	151
Rain sensor - windshield wipers	37
Reading lights - front/rear	74
Rear fog light	29, 34
Rear reading lights	74
Rear seat backrest	66
Rear window - heated	38
Rearview mirror	41
Refrigerant	47
Refueling	86
Remote central locking system and sideview mirrors system	41
Remote control - keyless entry system	77

Remote control - Homelink® Universal Transceiver	168
Remote keyless entry system	77
Remote keyless entry system - replacing batteries	78
Remote keyless entry system and driver's seat	57
Removing the seat cushion	66
Replacing bulbs	120-125
Replacing fuses	116
Replacing wiper blades	140
Road assistance	149
Roadholding	95
Roof load - maximum	143
Roof racks	97
S	
Safety locks - child	82
Seat belt maintenance	17
Seat belts	2, 3, 14
Seat belts - cleaning	128
Seats - front	56
Securing cargo	68
Servicing	133
Shiftlock	87, 90, 92
Side direction indicator - replacing	123
Side impact airbag system (SIPS)	8
Sideview mirrors	41
Sideview mirrors - heated	38
Sideview mirrors - memory function	41
Snow chains	109
Snow tires	109
Spare tire	72, 110
Spark plugs	132, 147
Specifications	144
SRS	6
SRS diagnostic system	28
Stability Traction Control (STC)	19, 31
Stain removal	128
Start inhibitor (immobilizer)	76, 87
Starting the engine	87, 88
Steel grid	69
Steering wheel adjustment	35
Steering wheel lock	35
Stop and Store bag	64
Storage compartments	59
Storage in the glove compartment	60
Studded tires	109

Subwoofer	72, 166
Sun roof	42, 43
Supplemental Restraint System	4, 28
Suspension	147
Switches in center console	31
T	
Tachometer	27
Tailgate - locking/unlocking	79
Tailgate wiper blade - replacing	140
Temperature gauge	27
Temporary spare tire	110
Text window	30
Three-way catalytic converters	106
Timing belt	132
Tire pressure	110
Tires	108 -111
Tires - changing	112, 113
Tool bag	72
Towing a trailer	101
Towing eyelet	99
Towing the car	99, 100
Trailer towing	101
Trailer weight - maximum	143
Transmission - automatic	90-94
Trip computer	32
Trip odometer	27
Turn signals	36
U	
Uniform tire quality grading	111
Unlocking the tailgate	79
Upholstery - cleaning	128
V	
Vanity mirror lights - replacing	124
Vehicle Identification Number (VIN)	142
Vehicle loading	110
Ventilation	46
Volvo On Call	149
Volumes (oils and fluids)	146
W	
Warning flashers	38
Warning light - center	28
Warning lights	28, 29
Warranty	129
Washer fluid reservoir	133

Washer fluid solvent	104
Washing the car	127, 128
Waxing	128
Weight distribution	95
Wheels - changing	112, 113
Wheels and tires	108-113
Whiplash Protection System (WHIPS)	10
Windows - electrically operated	40
Windshield washer solvent	104
Windshield wiper blades - replacing	140
Windshield wipers/washers	37
Winter driving	104
Winter tires	109
Winter/Wet driving mode	91, 93, 104
Wiper blades - replacing	140



[Contents](#) | [Top of Page](#)

2003 VOLVO V70

Back Cover

Back Cover

Accessory Installation - Important Warning

- We strongly recommend that Volvo owners install only genuine, Volvo-approved accessories, and that accessory installations be performed only by the factory-trained technicians at your authorized Volvo retailer.
- Genuine Volvo accessories are tested to ensure compatibility with the performance, safety, and emission systems in your car. Additionally, your authorized Volvo retailer knows where accessories may and may not be safely installed in your Volvo. In all cases, please consult your authorized Volvo retailer before installing any accessory in or on your car.
- Accessories that have not been approved by Volvo may or may not be specifically tested for compatibility with your car. Additionally, an inexperienced installer may not be familiar with some of your car's systems.
- Any of your car's performance and safety systems could be adversely affected if you install accessories that Volvo has not tested, or if you allow accessories to be installed by someone unfamiliar with your car.
- Damage caused by unapproved or improperly installed accessories may not be covered by your new car warranty. See your Warranty and Service Records Information booklet for more warranty information. Volvo assumes no responsibility for death, injury, or expenses that may result from the installation of non-genuine accessories.

Driver Distraction

- Driver distraction results from driver activities that are not directly related to controlling the car in the driving environment. Your new Volvo is, or can be, equipped with many feature-rich entertainment and communication systems. These include hands-free cellular telephones, navigation systems, and multipurpose audio systems. You may also own other portable electronic devices for your own convenience. When used properly and safely, they enrich the driving experience. Improperly used, any of these could cause a distraction.
- For all of these systems, we want to provide the following warning that reflects the strong Volvo concern for your safety:
 - Never use these devices or any feature of your vehicle in a way that distracts you from the task of driving safely. Distraction can lead to a serious accident.
 - In addition to this general warning, we offer the following guidance regarding specific newer features that may be found in your vehicles:
 - Never use a hand-held cellular telephone while driving. Some jurisdictions prohibit cellular telephone use by a driver while the vehicle is moving.
 - If your car is equipped with a navigation system, set and make changes to your travel itinerary only with the vehicle parked.
 - Never program your audio system while the vehicle is moving. Program radio presets with the vehicle parked, and use your programmed presets to make radio use quicker and simpler.
 - Never use portable computers or personal digital assistants while the vehicle is moving.

A driver has a responsibility to do everything possible to ensure his or her own safety and the safety of passengers in

the vehicle and others sharing the roadway. Avoiding distractions is part of that responsibility.

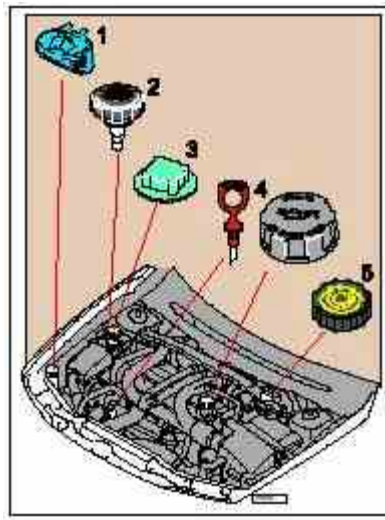

The following should be checked regularly: *

1 Washer fluid reservoir should be filled with water and solvent (wintertime: windshield washer anti-freeze). See [page 133](#).

2 Power steering - When cold, the level must not be above the COLD mark and when hot it must not be above the HOT mark. Top up if the level drops to the ADD mark with ATF fluid. See [page 137](#).

3 Coolant level should be between the expansion tank marks. Mixture: 50% anti-freeze and 50% water. See [page 131](#).

4 Engine oil level should be between the dipstick marks. The distance between the marks represents approx. 1.6 US qts (1.5 liters). See [page 135](#).

5 Brake fluid - check, without removing the cap, that the level is above the MIN mark. Use brake fluid DOT 4+. See [page 137](#).

* Engine oil should be checked each time the car is refuelled.



Octane rating, see [page 84](#).

Tire pressure, see label located on the rear edge of the right front door.

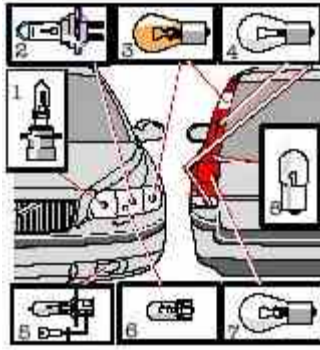

Bulbs Power Socket US no.

Bulb	Power	Socket	US no.
1	60 W	HB 3	-
2	55 W	H 7	-
3	21 W	BAU 15d	-
4	21 W	BA 15s	1156
5	55 W	H 1	-
6	5 W	W W2.1x9.5d	1157NA
7	21/4 W	BA 15d	
8	5 W	BA 15s	67

